

SM 2000

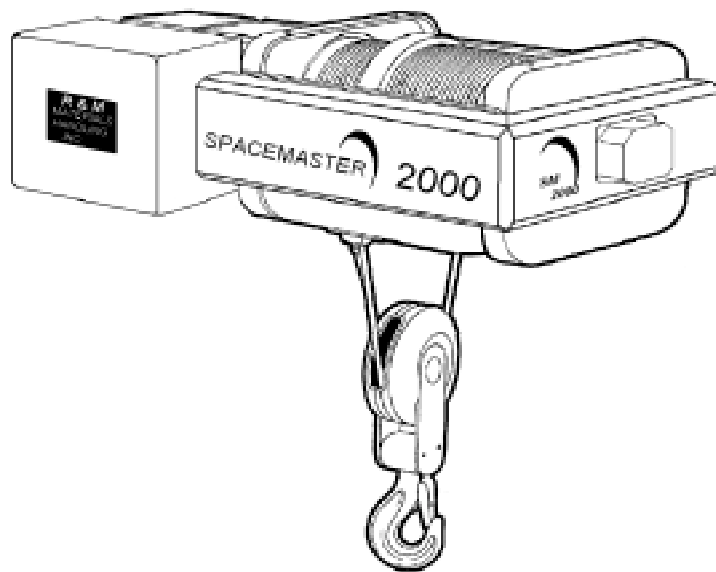

INSTALLATION MAINTENANCE SPARE PARTS

ELECTRIC WIRE ROPE HOIST TYPE SM 2000



TABLE OF CONTENTS

1.0 INTRODUCTION

- 1.1 Scope
- 1.2 General
- 1.3 Design
- 1.4 Standard Warranty
- 1.5 Repair Parts
- 1.6 Damage During Shipment
- 1.7 Handling and Storage

2.0 INSTALLATION AND START-UP

- 2.1 General
- 2.2 Mounting
- 2.3 Installing Hoist with Low Headroom Trolley
- 2.4 Installing Hoist with Standard Headroom Trolley: SM1 thru SM3
- 2.5 Installing Hoist with Standard Headroom Trolley: SM4 and SM5
- 2.6 Installing Hoist with a Double Girder Trolley
- 2.7 Installing a Stationary Hoist
- 2.8 Electrical Connections
- 2.9 Check Hook Travel Direction (UP or DOWN)
- 2.10 Check Trolley Travel Direction
- 2.11 Pre-commissioning Inspections
- 2.12 Load Hook Throat Opening

3.0 SAFE OPERATING PRACTICES

- 3.1 General
- 3.2 DO's and DON'TS

4.0 CONSTRUCTION AND OPERATING PRINCIPLES

- 4.1 Hoist unit
- 4.2 Basic Operation
- 4.3 Frame
- 4.4 Trolleys
- 4.5 Drum
- 4.6 Wire rope system components
- 4.7 Load limiter
- 4.8 Limit switches
- 4.9 Trolley Drive Assembly
- 4.10 Wheels

5.0 HOIST MOTORS

- 5.1 Description
- 5.2 Connections

6.0 HOIST GEARBOX

- 6.1 Types of gearboxes
- 6.2 Disassembly – Re-assembly
- 6.3 Gearbox Inspection

7.0 HOIST MAINTENANCE

- 7.1 General
- 7.2 Maintenance operations and periodic inspections
- 7.3 Parts subject to wear
- 7.4 Lubrication
- 7.5 Wire rope

A.0 APPENDICES

- A.1 Replacement Criteria for Wire Ropes
- A.2 Replacement Criteria for Wheels
- A.3 Replacement Criteria for Sheaves

1.0 INTRODUCTION

1.1 Scope

This manual has been prepared to acquaint you with the procedures necessary for the installation, operation, and maintenance of the hoist you have purchased.

Proper installation is important to the ultimate performance of this equipment. Careful study of and adherence to the instructions will help assure safe, dependable operation. It is also recommended that you keep this manual readily accessible in case of an emergency.

1.2 General

When a hoist is supplied without controls, the Purchaser is responsible for making proper electrical connections to the hoist motor brake and the hoist motor thermal protection devices.

The hoist is fitted with a load limiting device. A serial plate shows key information including the model number, capacity, and serial number. This information will allow us to supply you maintenance support and replacement parts subject to wear.

If your unit includes options or special features, it may be equipped with a special or additional electrical cabinet. Before installation, make sure that this will not present an obstacle.

1.3 Design

Your hoist has been designed for a specific duty rating. This duty rating is a function of actual operating time per day, number of starts per hour, and a weighted average load. The theoretical service life, excluding wear items, before "general overhaul" is 10 years.

The hoist cannot be overloaded (load limiter provided as standard), but the demand (average time load and average load) may exceed the theoretical value for which the hoist has been designed. It is extremely important to check on the state of wear items, since its service life could be reduced more quickly than anticipated. A hoist which is under-used will have a longer service life.

During maintenance operations, it is important to assess that the use of the equipment corresponds to the initial specified duty rating. The hoist is designed for a given lifting capacity and load scope; while the capacity is limited by the "load limiter", the load scope, by contrast, does not have a limiting device.

If the motor is over-used, it may overheat causing the thermal protection devices to trip and stop the lifting process; the wear suffered by the equipment will be abnormally fast. It is important to ensure that the equipment is used under the conditions for which it was designed. Regular maintenance is the key to satisfactory operation over the life of the hoist.

1.4 Standard Warranty

Please refer to R&M Materials Handling, Inc.'s current Price Book Section – "Business Policy" for explanation of Warranty and Warranty Support.

1.5 Repair Parts

Repair parts are sold through Authorized Parts Distributors. If you need support in locating access to repair parts or warrant, please contact the the Factory.

R&M Materials Handling, Inc.
4501 Gateway Blvd.
Springfield, Ohio 45502
Ph. 937-328-5100
Fax. 937-325-5319

1.6 Damage During Shipment

All shipments are carefully inspected and delivered to the carrier in good order. If you have received a shipment with damage or loss, please notify the carrier immediately.

1.7 Handling and Storage

Your hoist was packaged to insure that damage would not happen during shipment. It must be handled by competent personnel to avoid damage to the product. Check the weight of the equipment purchased to make certain the handling equipment being used is capable of moving the new equipment.

When using lifting chains, slings, or hooks, you **MUST** use the anchor points provided for this purpose, cut-outs in the body, or suspension rings or holes (see sling attachment markings); if necessary, use cross-members and struts on the body.

DO NOT suspend the equipment by the counterweight, the electric cabinet, the drum, or the geared motors.

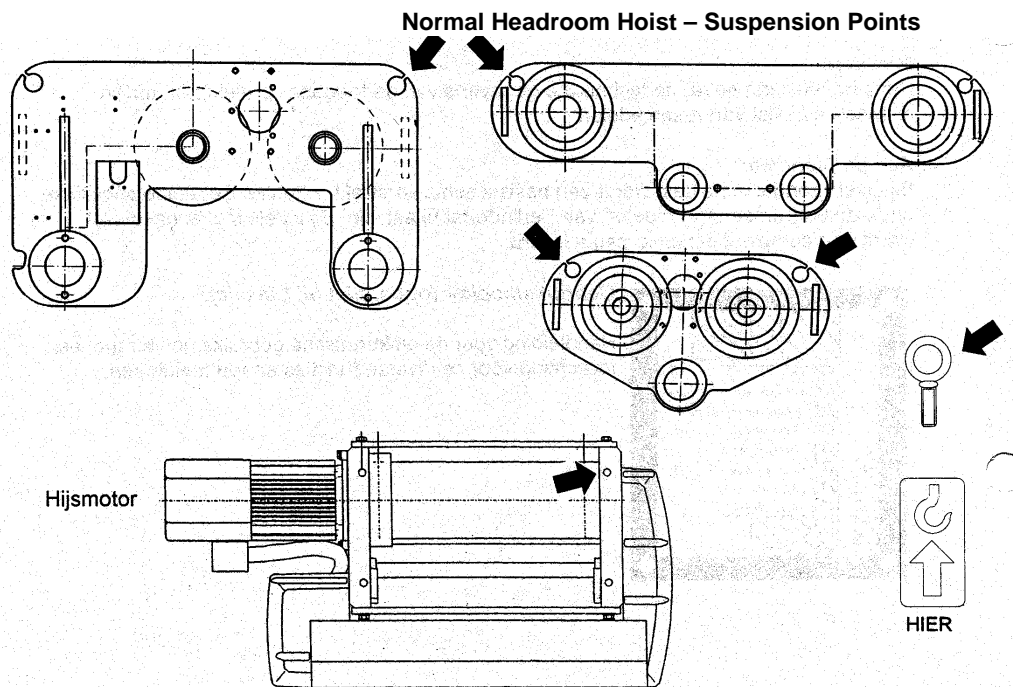

During storage, insure that the hoist is supported in such a way as to avoid damage or kinking of the hoist wire rope and electrical cables. Make certain the hoist is placed horizontally on its body, and **NOT** on the electric cabinet, the jackshaft subassembly, the counterweights, etc. Proper storage includes being shelter in a facility that provides protection against outside weather conditions and corrosive vapors.

2.0 INSTALLATION AND START-UP

IMPORTANT : Hoists / Trolleys are designed for only lifting and transporting of materials. Under no conditions or circumstances, either during initial installation or in regular use, are hoists to be used for lifting or transporting of personnel.

2.1 General

Each complete Spacemaster Hoist is load tested at the factory at 125% of rated capacity and shipped assembled. Units purchased and shipped without any or all of the following items are only bench tested. These items include: motors, controls, bottom blocks, or other items which do not allow complete testing. The test report supplied with each hoist will confirm the level of testing completed at the Factory.

All hoists / trolleys are designed for the type of mounting specified by the purchaser. The adequacy of the supporting members (monorail beams, cranes, hangers, supports, framing, etc.) is the responsibility of the Purchaser and shall be determined by qualified personnel.

Prior to installation, the unit should be checked thoroughly for damage during shipment or handling at the job site. Particular attention should be taken to make sure that the hoisting wire rope and limit switch mechanism has not been damaged by improper use of forklifts or sling chains.

Read the instructions contained in this manual and observe the warning tags attached before installation is started.

WARNING: Before installation of hoist, insure that the main power switch applying electrical power to the hoist is "OFF" and locked position.

2.2 Mounting

Before installing trolley mounted hoists, rail stops must be installed for all trolleys mounted on open end beams. These stops must be positioned so that impact forces are absorbed only by the trolley side frames. Do not allow trolley wheels to impact rail stops.

Spacemaster hoists are balanced at the factory for the "as shipped" condition. Any auxiliary devices (control boxes, cable reels, lights, horns, etc.) furnished and mounted by the Purchaser may require the adjustment or addition of counter-weight. Hoists must hang straight without a load. Do not operate a hoist if the wheels are not in contact with the beam.

2.3 Installing Hoist with the Low Headroom Trolley

Your hoist is supplied already adjusted for specified beam flange width. "Dimension C" depends on the width of the beam flange and is governed by the upper limit switch. To install the hoist, tilt the trolley to place the wheels onto the beam.

- Remove the bolts, item 1, in below figure.
- Turn threaded collar, item 2, to obtain necessary clearance to allow the trolley to be tilted and slipped onto the beam flange.
- Turn threaded collar, item 2, back to original position for proper flange setting.
- Measure the flange-to-flange distance to check that the end plates of the trolley are parallel.
- The total clearance between the wheels and beam flange: 1/8" - 3/16" (3-5 mm).

- Replace the bolts with Locktite 243, item 1, and tighten to secure permanent position of side plate assembly.

"Dimension C"

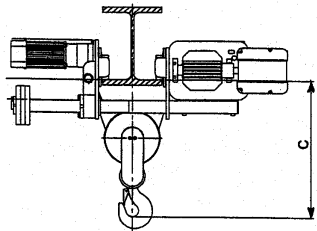

- 1 Bolt
- 2 Threaded collar
- 3 Trolley plate assembly

Adjustment on beam flange

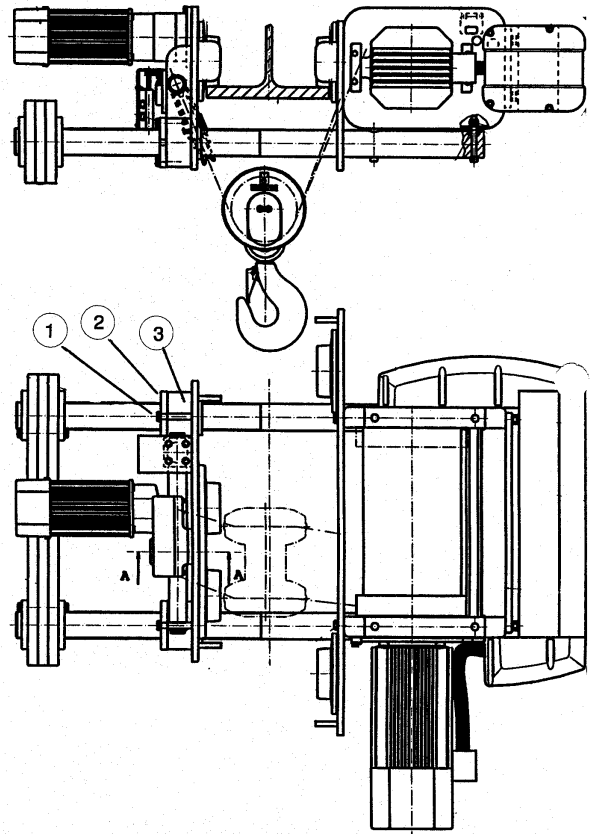
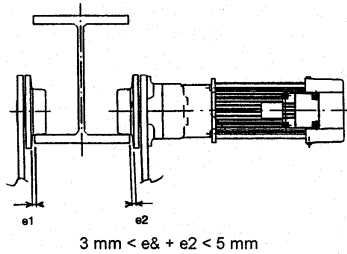

Low Headroom Hoist Assembly

2.4 Installing Hoist with the Standard Headroom Trolley : Models SM1 to SM3

Your hoist is supplied already adjusted for your specified beam flange width. "Dimension C" depends on the width of the beam flange and is governed by the upper limit switch. To install the hoist, tilt the trolley to place the wheels onto the beam.

Preliminary adjustment has been made with the aid of the adhesively-bonded bolts. The clearance between spacers and disks have been set to center the load on the beam. It is important to follow the procedure described below :

To install the hoist, following the two examples given below :

Note : In both cases, you must tilt the trolley by releasing or opening by partial disassembly. In the case of a narrow beam design, the two trolley end plates are on the "inside" of the hoist side panels, and it may be impossible to tilt it sufficiently to release it so as to allow it to be fitted to the beam without disassembly.

In both cases, the preliminary setting at the Factory (with the use of Locktite-bonded bolts) must not be changed except for special circumstances:

- The total clearance between the wheels and beam flange : 1/8" - 3/16" (3 - 5 mm).
- The flange-to-flange distance between the wheels must be parallel.

HOIST ASSEMBLY - Standard Headroom Trolley

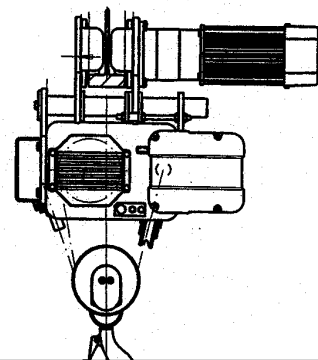
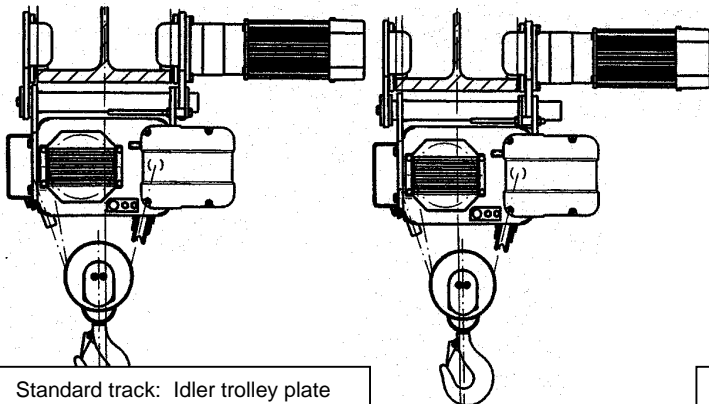
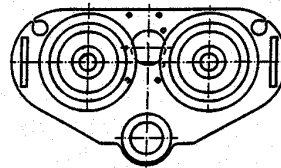
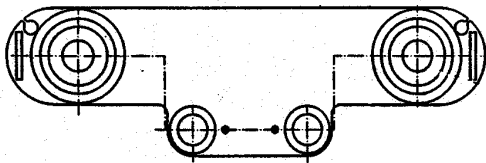
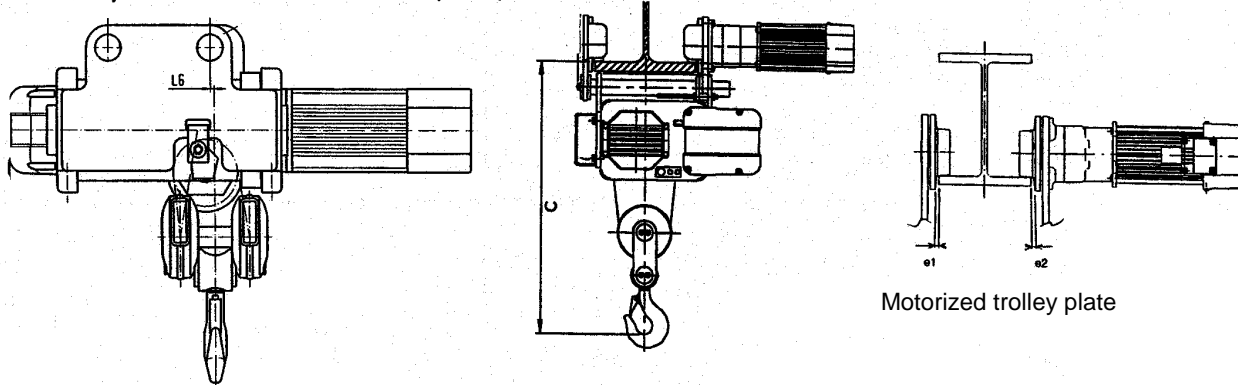

A) Standard track: Idler trolley plate located outside hoist body.

B) Narrow track: Idler trolley plate located inside the hoist body.

LARGE BEAMS : Idler trolley plate located outside the hoist body side plate.

The drive trolley plate is pre-adjusted and secured with adhesively bonded bolts at the factory for the specified beam flange width. The Idler trolley plate is tilted for installation:

- Remove the two NYLSTOP nuts, item 1, on the idler sideplate
- Turn the threaded screw until sufficient clearance is achieved for mounting the hoist to the beam
- Position the hoist on its beam
- Re-position the trolley side plate with the aid of the threaded screw returning to original setting.
- Install the NYLSTOP nuts. Check the clearance between wheel and beam flanges - 1/8" to 3/16" (3 - 5 mm).

TROLLEY, Idler trolley plate outside of hoist body

Top View

- 1 NYLSTOP nut
- 2 Oblong stop plate
- 3 Idler trolley plate
- 4 Long bolts x 2
- 5 Spacers and disks
- 6 Callipers, 1 std., 1 with bolt w/ welded spacers
- 7 Trolley frame side plate
- 8 Adjusting panel
- 9 Transverse tie-rod

Trolley frame side frame -----

Idler Trolley Plate -----

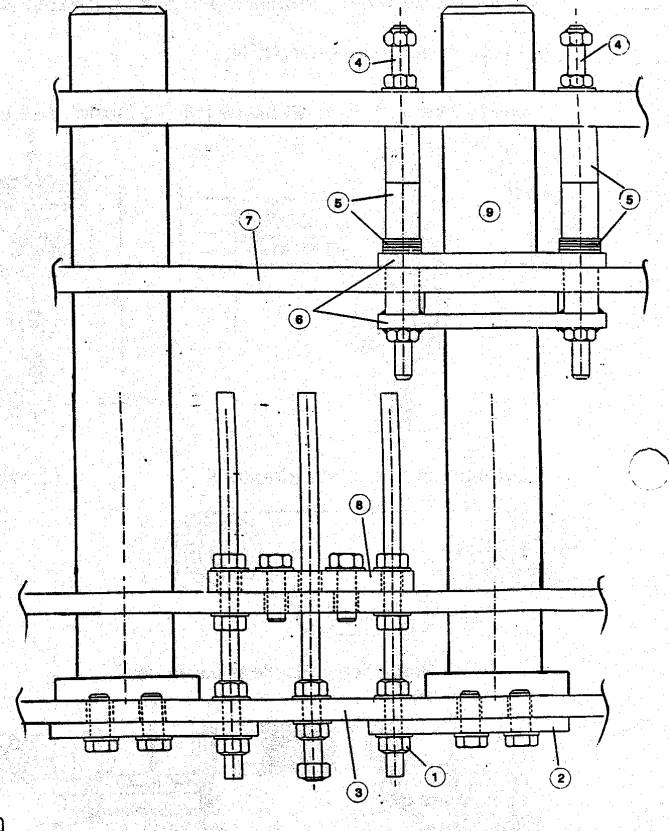

Beam Adjustment

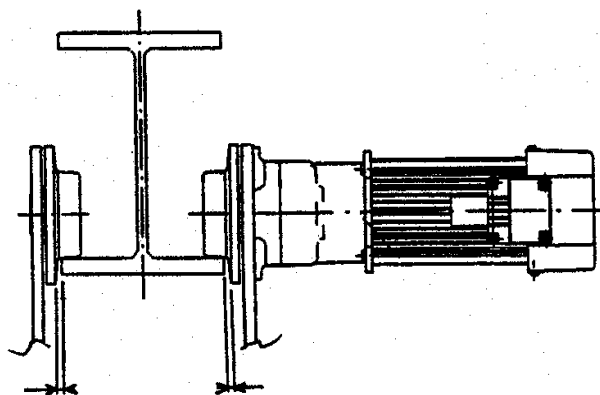

Adjustment should be made so that the total clearance between the wheel flanges and the beam flange is :

$1/8 - 3/16$ inches / (3 – 5 mm)

SMALL BEAMS: Idler trolley plate located inside hoist body side plate

The main tie-rod must be disassembled. In this case, the idler trolley plate should **NOT** be taken out of position.

- Idler trolley Plate: Remove NYLSTOP nut, item 1, which locks the stop plate, item 2, to the end plate, item 3.
- Hoist Body Side plate, motor side, item 7: Remove the two long bolts, item 4; the spacers and disks, item 5; and the callipers, item 6.
- Remove tie-rod, item 9 on the IDLER side until the motorize plate, item 7, can be removed.
- (CAUTION: THE TIE-ROD IS HEAVY),
- Position the hoist on the track, guide the motorized end plate into position, and fit the tierod across
- Refit the callipers
- Replace the two long bolts, spacers, and disks, and apply adhesive (LOCTITE 243)
- Resecure the stop plate 2 (NYLSTOP)
- Check total clearance between wheels and beam flange: 1/8"– 3/16" (3 to 5 mm)
-

TROLLEY, Idler trolley Plate Inside Hoist Body

- 1 NYLSTOP nut
- 2 Oblong stop plate
- 3 Idler Trolley Plate
- 4 4 Long bolts x 2
- 5 Spacers and disks
- 6 Callipers, 1 standard +
1 with bolts and welded spacers
- 7 Trolley frame cross-member
- 8 Adjusting panel
- 9 Transverse tierod

Idler Trolley Plate -----

Trolley Frame Side Plate -----

Top View

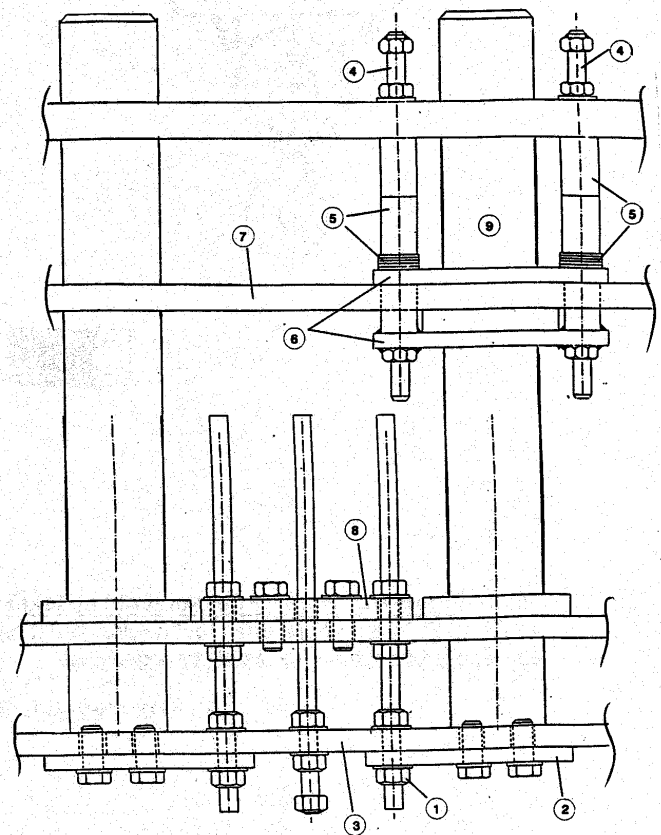

2.5 Installing Hoist with Standard Headroom Trolley : Models SM4 and SM5

The trolleys are symmetrical.

- Loosen the bolts, item 1; tighten the bolts, item 2, in order to tilt the trolley
 - Position the trolley on the beam
 - Push the trolley drive plates, item 3, into position and tighten bolts, item 1 and 2 using Loctite 243.
- For certain beam widths, it may be necessary to dis-assemble the trolley

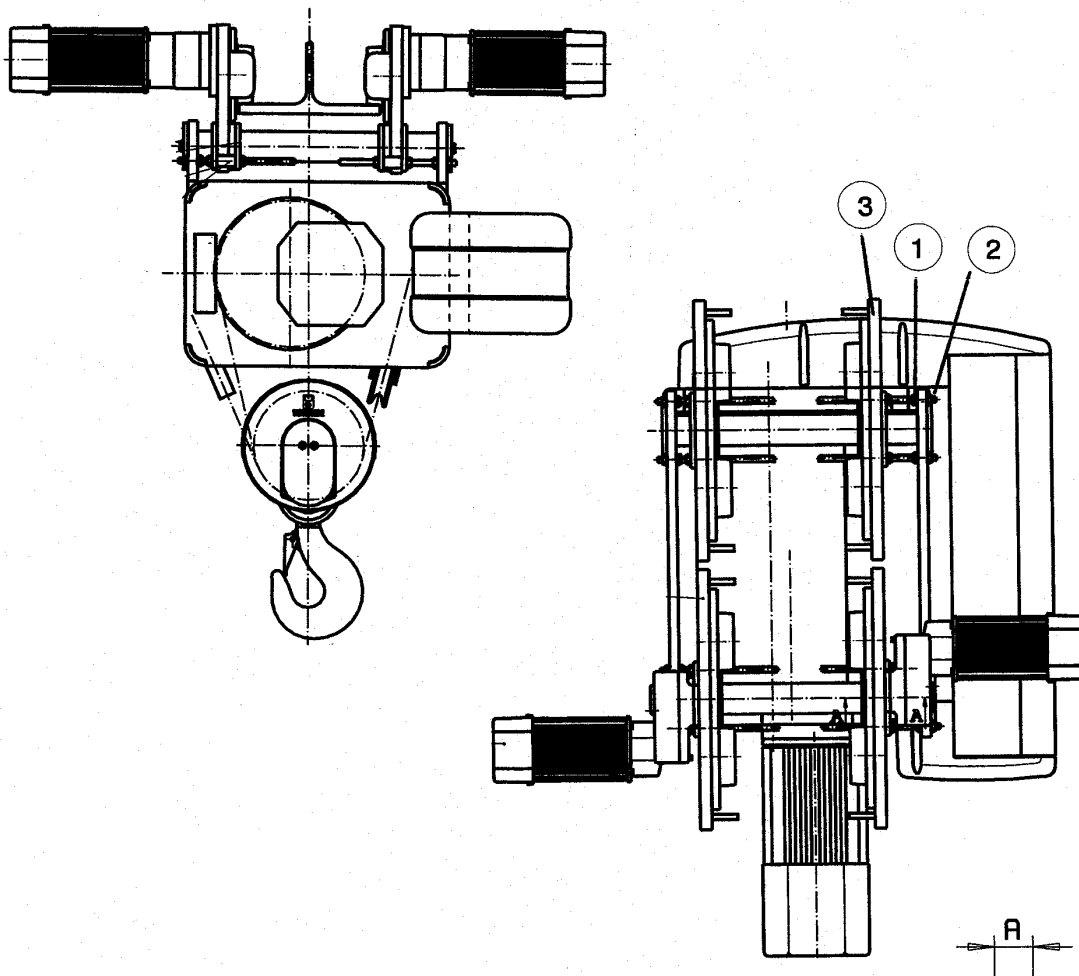

2.6 Installing Hoist with a Double Girder Trolley

Checks:

- Verify that the rail gage on the crane is the same as the hoist before starting.
- Verify that the flange with of the trolley wheels is correct for the size of the rails.
- Make sure that the lifting equipment will handle the load.
- When using slings, make certain that the assembly is properly balanced and that the sling is not sling too short.

Note: The motor side of the hoist is heavier.

- After positioning the Double Girder Trolley Hoist on the rails, check that the four wheels are touching the rail. Consult the Factory, if any problems are found.

2.7 Installing a Stationary Hoist

- Make certain that the lifting the equipment will handle the load.
 - In When using slings, make certain that the assembly is properly balanced and that the sling is not sling too short.
- Note: The motor side of the hoist is heavier.
- Check to make certain that the support side of the hoist will not touch the rope during use including a slight degree of sway from the bottom block.

2.8 Electrical Connections

A wiring diagram is included in this manual showing the identification of the power lead connections. Refer to the wiring diagram prior to start-up and / or any electrical work. If the wiring diagram has been misplaced, you may obtain one from the Parts Department at the Factory. You must provide the serial number from the hoist unit related to your inquiry.

Make certain that the power supply voltage is the same as that shown on the hoist nameplate and protected by fuses or other current overload devices. The electrical conductors must be sized to maintain the specified voltage at the hoist to within plus or minus ten percent (10%) of the nominal voltage under all operating conditions. Improper voltage maintenance can cause motor overheating, sluggishness, chattering, or inoperative brakes and controls.

CAUTION: Make certain the power source disconnect is in the off position and locked in place while making connections. Make certain that all collectors, if furnished, are compatible and properly lined up with good contact with the conductor bars.

Note: All standard Spacemaster Hoists are furnished with motor and control circuit protection which, in R&M Materials Handling, Inc.'s intpretation, meet the requirements of the National Electric Code in effect at time of shipment. The protective devices required for the power feed are outlined in Article 610 of the NEC, and are the responsibility of the user. It is recommended that this article be reviewed by the Purchaser for compliance requirements.

TEMPERATURE PROTECTION FOR MOTORS

The hoist motor is protected by a "thermistor" heat sensor assembly, which protects it against overheating. If your equipment is equipped with the "electronic control unit" option, the sensors are connected to this unit (see the documentation corresponding to the processing of this information). If your equipment is supplied without this electronic control unit, the function is controlled by controls supplied. The sensors must be connected at all times. It is recommended that the installer follow National, State, and Local Codes when providing electrical service to the hoist. All electrical connections shall be made only by a qualified electrician.

WARNING: Check all "motion" buttons in the push button station to insure that all are free from binding and sticking in any position before connecting the hoist to the power supply. Check pendant cable and supporting wires to ensure they are not damaged.

Once power has been supplied to the hoist, proceed and perform the following checks.

2.9 Check Hook Travel Direction (UP or DOWN).

Since the direction of rotation of any three-phase A.C. motor can be reversed by reversing any two of the three lines feeding the motor, it is important that the direction of travel corresponds with the button being depressed.

To check / correct hook travel direction, carefully inch the UP BUTTON and observe the direction of travel for the hook. If the hook does NOT travel UP, stop and open the power source disconnect.

WARNING: Do not attempt to reverse hoist motion by changing control leads in the push button or at the contactor, and do not change the name plate on the P/B. The pilot circuit limit switch is in series with the "UP" control circuit wiring as furnished from the Factory. Changing the push button control leads or nameplates will prevent the limit switch from functioning properly.

IMPORTANT: Do not run the hoist with the down button if direction is reversed. To correct the direction of the hook travel, reverse any two leads supplying power to the hoist, at the main power source, or at the lead-in connections to the hoist. Do not change the internal wiring of the hoist.

2.10 Check Trolley Travel Direction

If necessary to change trolley motion to orient direction with P/B marking, change any two power leads only at the load side of the trolley contactor.

CAUTION: Do not reverse main power leads for trolley motion correction. This will also cause a reversal of hoist motion, with resulting hazards at limit switch as listed above.

2.11 Pre-Commissioning Inspections

It is essential that the installation tests be carried before taking the system into service.

- Check the play between wheels and rail
- Correct tightness of structural bolts, adhesive bonding of main bolts (particularly if disassembly or loosening has been carried out)
- Check top limit switch (and adjustment of "size C")
- Check bottom limit switch (no contact with ground)
- Position of horizontal movement limits (pay attention to obstacles)
- Check direction of operation of the control elements
- Satisfactory condition of hoist rope
- Function check, possible adjustment of load limiter (or of electronic control unit)
- And, more generally, check for any anomalies which might have been incurred during transport
- Check that all tools, slings, securing rings, etc. have been removed from the equipment.

2.12 Load Hook Throat Opening

It is recommended that the throat opening of the load hook be measured and recorded prior to putting the hoist in service and that a gage be made to provide a quick visual inspection for a bent hook as required during monthly inspections by ANSI B30.16-1995.

3.0 SAFE OPERATING PRACTICES

3.1 General

There is no one single factor that is more important for minimizing the possibility of personal injury to the operator and those working in the area, or damage to property, equipment, or material, than being familiar with the equipment and using SAFE OPERATING PRACTICES.

Hoist / trolleys are designed ONLY for lifting and transporting of material. Under no circumstances, either during initial installation or in any other use, should the hoist be used for lifting or transporting personnel.

Only operators familiar with the operation of the equipment should be permitted to use the equipment. The operators should be mentally and physically competent and schooled in SAFE OPERATING PRACTICES. The misuse of hoists can lead to certain hazards which can not be protected against by mechanical means; hazards which can only be avoided by the exercise of good judgment and acquired skills.

SAFE OPERATING PRACTICES also involves a program of periodic inspection and preventative maintenance. Part of the operator's training should be an awareness of potential malfunctions / hazards requiring adjustments or repairs, and bringing these to the attention of supervision for corrective action.

Management also has an important role to play in any safety program by assuring that a maintenance schedule is adhered to, and that the equipment provided for the operators is suitable for the job intended without violation of one or more of the rules covering safe operating practices and common sense.

The SAFE OPERATING PRACTICES shown are taken in part from the following publications:

American National Standard Institute (ANSI)
Safety Standards for Cranes, Derricks, Hoists
ANSI B30.2 – Overhead and Gantry Cranes
ANSI B30.16 – Overhead Hoist

3.2 DO'S AND DON'TS

The following are DO'S and DON'TS for safe operation of overhead hoists. Taking precedence over any specific rule listed here is the most important rule of all - USE COMMON SENSE. A few minutes spent reading these rules can make an operator aware of dangerous practices to avoid and precautions to take for his own safety and the safety of others. Frequent examinations and periodic inspections of the equipment as well as a conscientious observance of safety rules may save lives as well as time and money.

DON'TS - HOISTS

1. NEVER lift or transport a load until all personnel are clear and DO NOT transport the load over personnel.
2. DO NOT allow any unqualified personnel to operate hoisting equipment.
3. NEVER lift a load beyond the capacity rating appearing on the hoist. Overloading can be caused by jerking as well as by static overload.
4. NEVER carry personnel on the hook or the load.
5. DO NOT operate the hoist if you are not physically fit.
6. DO NOT operate hoist to extreme limits of travel of chain or rope without first checking for proper limit switch operation.
7. AVOID sharp contact between two hoists or between hoist and end stops.
8. DO NOT tamper with or adjust any parts of the hoist unless specifically authorized to do so.
9. NEVER use the hoist rope or chain as a sling.
10. DO NOT divert attention from load while operating hoist.
11. NEVER leave a suspended load unattended.
12. DO NOT use limit switch(es) for normal operating stop(s). These are safety devices and should be checked on a regular basis for proper operation.
13. NEVER operate a hoist which has an inherent or suspected mechanical or electrical defect.
14. DO NOT use chain or rope as ground for welding. NEVER touch a live welding electrode to the chain or rope.
15. DO NOT jog controls. Hoist motors are generally high torque, high slip types. Each start creates a inrush of current greater than the running current and leads to over-heating and heat failure, or burn-out, if continued to excess.

DO'S – HOISTS

1. **READ** and follow manufacturer's instruction, installation, and maintenance manuals. When repairing or maintaining a hoist, use only manufacturer's recommended parts and materials.
2. **READ** and follow all instruction and warning information on or attached to a hoist.
3. **REMOVE** the hoist from service and thoroughly inspect and repair, as necessary, if unusual performance or visual defects (such as peculiar noise, jerky operations, travel in improper direction or obviously damaged parts) are noticed.
4. **ESTABLISH** a regular schedule of inspection and maintain records for all hoists with special attention given to hooks, ropes, brakes, and limit switches.
5. **CHECK** operation of brakes for excessive drift.
6. **CHECK** operation of limit switches.
7. **CHECK** for damaged hooks and wire ropes.
8. **KEEP** load wire rope clean and well lubricated.
9. **CHECK** the wire rope for improper seating, twisting , kinking, wear, or other defects before operating the hoist.
10. **CHECK** for broken wires in wire rope. See Wire Rope Section for complete inspection procedure.
11. **MAKE CERTAIN** a load clears neighboring stock piles, machinery, or other obstructions when raising, lowering, or moving the load.
12. **CENTER** hoist over the load before connecting and lifting the load.
13. **AVOID** swinging of load or load hook when moving the hoist.
14. **BE CERTAIN** the load attachment is properly seated in the saddle of the hook. Balance load properly before handling. Avoid hook tip loading.
15. **PULL** in a straight line, so that neither hoist body object.
16. **TAKE** up slack slowly.
17. **KNOW** the hand signals for hoisting, cross travel, and crane travel if working with cab operated hoists or cranes. Operators should accept the signals of only those persons authorized to give them.

4.0 CONSTRUCTION AND OPERATING PRINCIPLES

4.1 Hoist unit

The hoist unit is made up of an assembly consisting of the motor, hoist gearbox, and drum, supported by a frame. This unit supports the force applied through wire rope system (rope, block assembly, hook, attaching points) which transfers the load to the frame and to the trolley, if mounted.

Main hoist components:

- | | | | |
|---|------------------|---|--------------------------------------|
| 1 | Motor | 6 | Rope guide ring |
| 2 | Integrated brake | 7 | Hoist body: End plate |
| 3 | Coupling | 8 | Hoist body: Frame side pieces |
| 4 | Hoist gearbox | 9 | Electrical controls (standard model) |
| 5 | Rope drum | | |

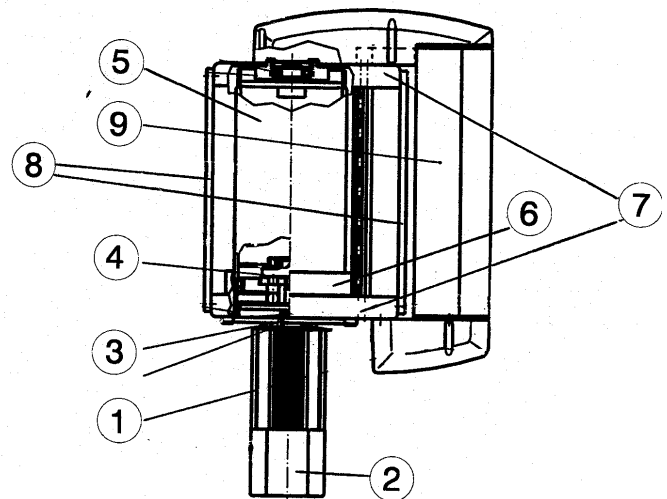

4.2 Basic Operation

The motor is controlled by the electrical controls and a push button pendant. When the motor, item 1, is energized, the disk brake, item 2, releases. Then the motor delivers its torque to the gearbox, item 4, via a coupling, item 3. The gearbox steps down the speed and increases the torque transmitted to the drum, item 5.

For hoist sizes SM 1, 2, and 3, the last gear reduction is provided by an output gear from the gearbox which engages with a ring gear attached to the drum.

For hoist sizes SM4 and 5, the gearbox engages the drum by means of a central drive train.

Crown wheel drive

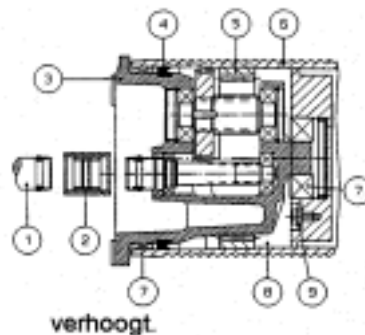

Central drive train

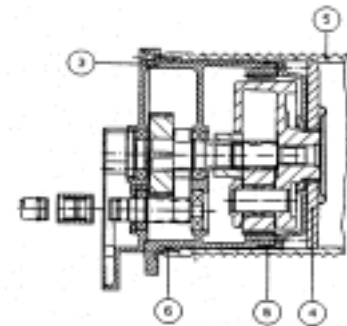

- | | | | | | |
|---|------------------|---|------------------|---|-------------------|
| 1 | Motor shaft | 6 | Drum | 3 | Gearbox, assembly |
| 2 | Coupling | 7 | Roller cages x 2 | 4 | Drive disk |
| 3 | Gearbox assembly | 9 | Magnet | 5 | Drum |
| 4 | Lever joint | | | 6 | Roller cages x 2 |
| 5 | Crown wheel | | | | |

During the rotation of the drum, the rope is guided precisely onto the drum by the rope guide ring, item 6.

4.3 Frame

The steel frame is made up of two end-plates and two side-plates, bolted together.

CAUTION: Some of the assembly points are constructed with high-strength bolts with adhesive bonding (LOCTITE brake thread 243). The type of side plates will differ depending on the type of trolley selected.

NEVER use the handling point for suspension. The frame side pieces are designed to accommodate the load and transfer it to the trolley (monorail design). The frame of the hoisting unit is not completely separate from the trolley.

4.4 Trolleys

CAUTION: In the case of a monorail hoist mounted on a large beam: The side "C" dimension is limited by the "V" angle formed by the rope. It is important that the upper hook travel limit is correctly set by the upper/ lower limit switch.

"C" Dimensions (Fixed / Monorail / Double girder)

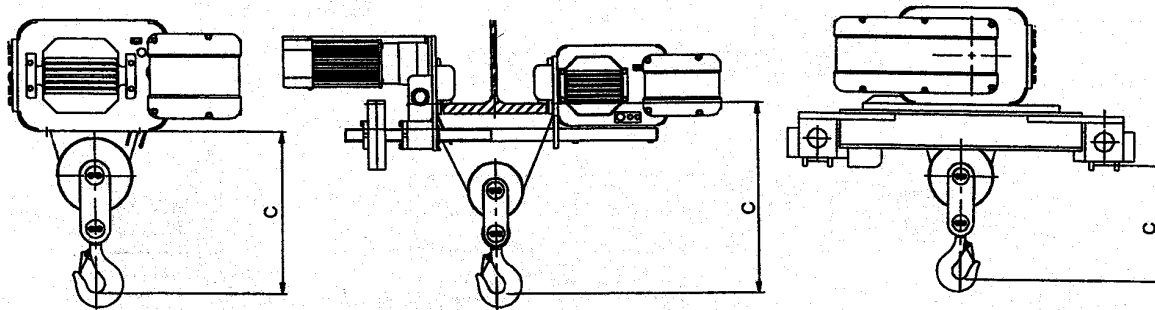

Low Headroom Trolley

Model – Low Headroom

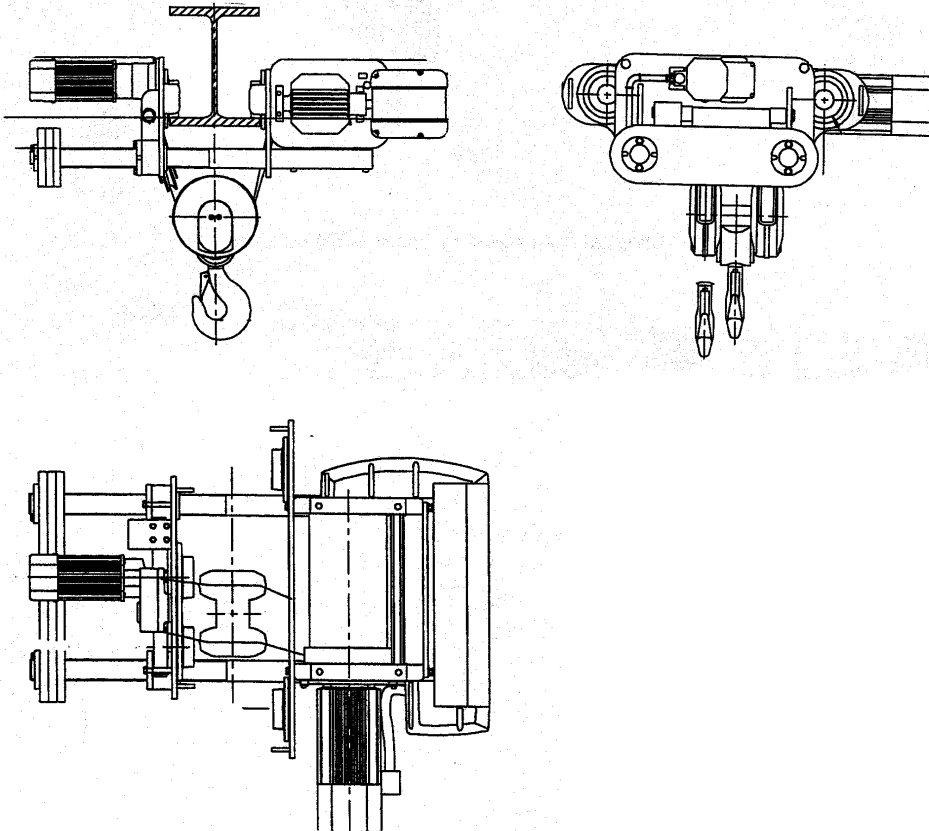

Standard Headroom Trolley

Swival end plate

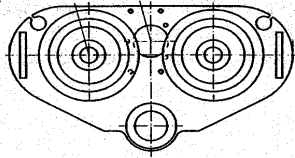

Fixed end plate

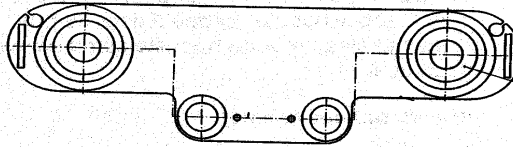

Model – Standard Headroom : sizes SM1 to SM3

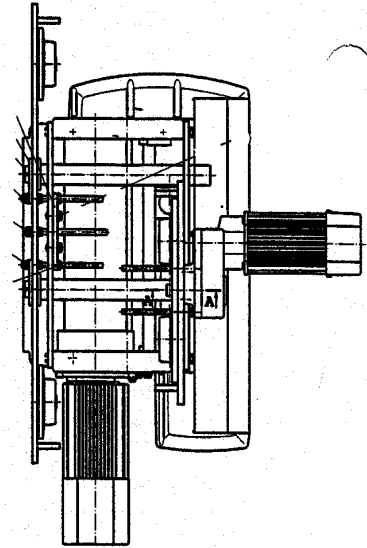
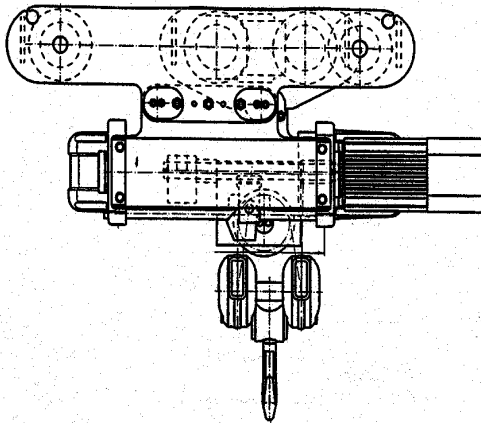
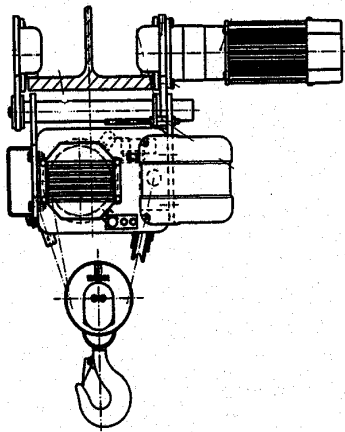

Model – Standard Headroom : sizes SM4 and SM5

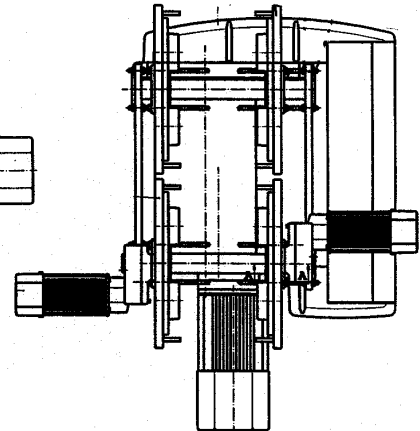
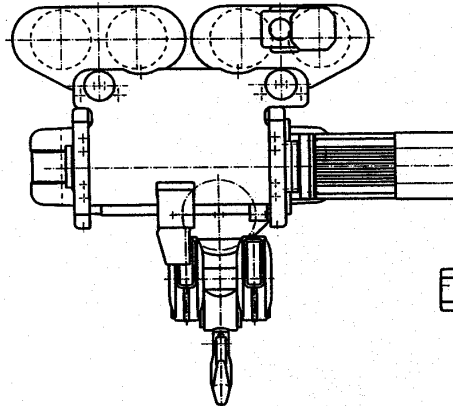
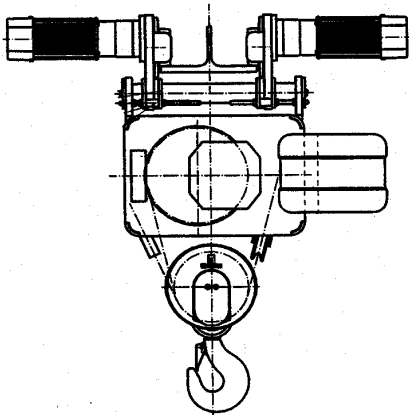

Model - Double Girder Trolley, Parallel : sizes SM2 and SM3 (Drum is parallel to bridge girder)

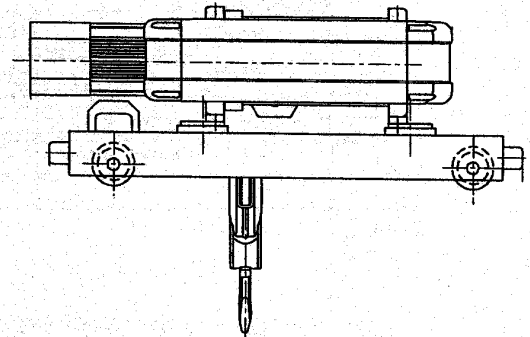
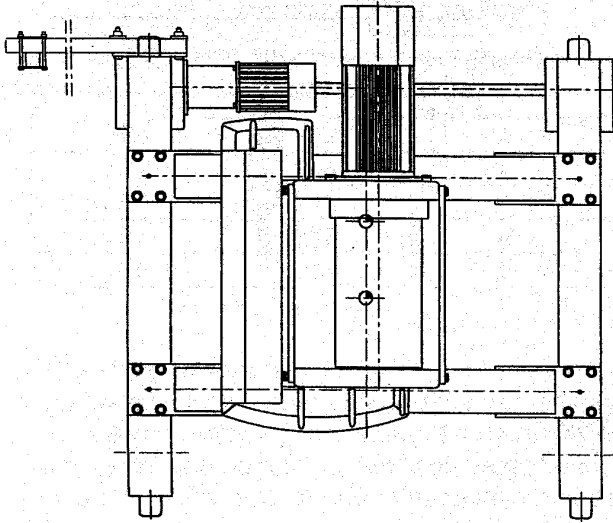

Model - Double girder parallel type, sizes SM4 and SM5

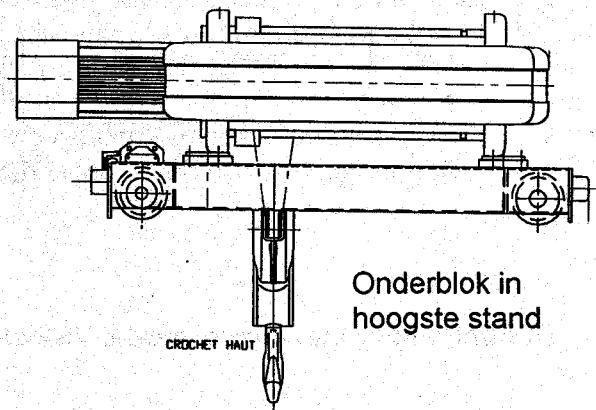
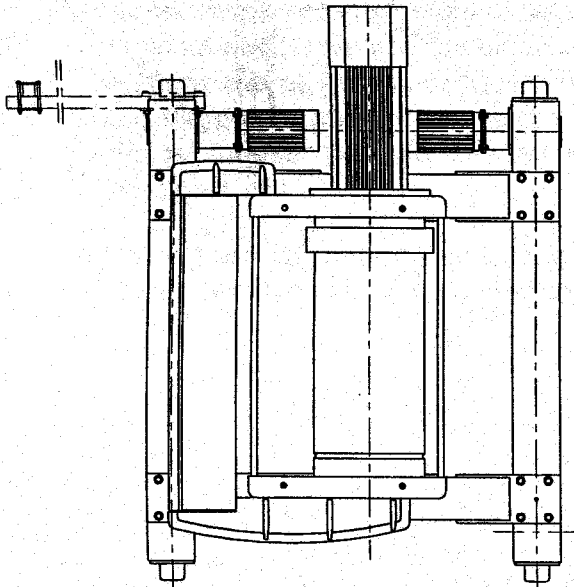

Onderblok in
hoogste stand

Model -Double Girder Trolley, Perpendicular : sizes SM2 and SM3 (Drum is perpendicular to bridge girder)

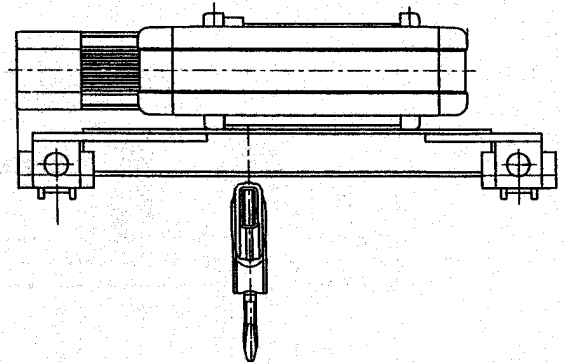
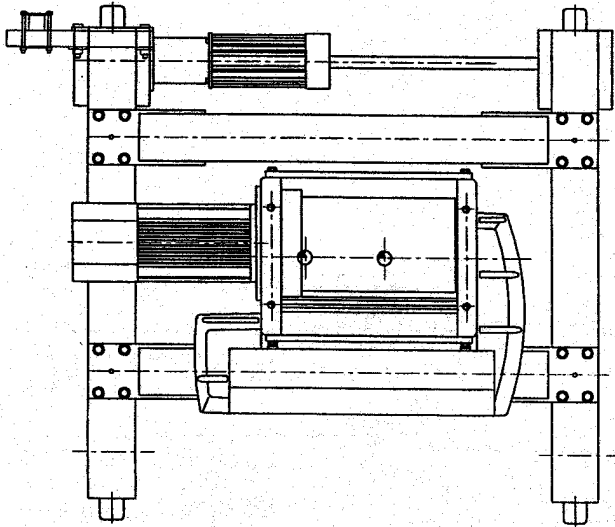

Model - Double Girder Trolley, Perpendicular : sizes SM4 and SM5 (Drum is perpendicular to bridge girder)

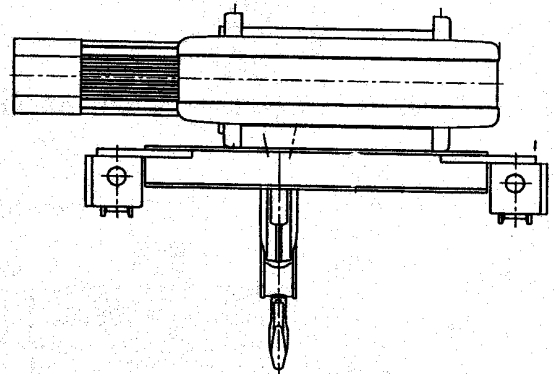
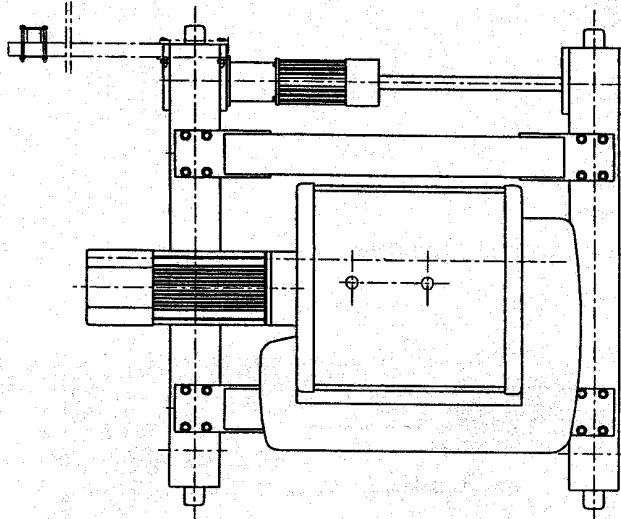

4.5 Drum

The drum consists of a steel tube which is grooved to take up the rope without the risk of fouling. The length of the drum determines the length of the rope, and therefore the height of the lift. Drum diameters and lengths are as follows:

Block falls	Rated dia. (mm/in.)	Standard Length		Length : mm / inches	
1	152 mm / 5.98 in.	A		A = 510 mm / 20.1 in.	B = 620 mm / 24.4 in.
2	244 mm / 9.61 in.	A		C = 720 mm / 28.3 in.	D = 900 mm / 35.4 in.
3	244 mm / 9.61 in.	A	C	E = 1400 mm / 55.1 in.	F = 1700 mm / 66.9 in.
4	318 mm / 12.5 in.	B	D		
5	369 mm / 14.5 in.	D	E	G = 2000 mm / 78.7 in.	

Drum Length Adjustment

The end of the drum, on the gearbox side, should be on the level of the inside face of the frame end plate. On models SM 4 and SM5, the longitudinal positioning of the drum can be adjusted by the mounting of the rollers (in the end plate), which is grooved. On models SM1 to SM3, this drum position is fixed by the geometry of the frame, and the careful tightening of the main bolts.

Torque transfer

On blocks of sizes SM1 to SM3, the drum has a hardened steel ring gear, item 6. The gearbox is "open" inside the drum, with an output pinion gear transferring the torque to the drum ring gear. The drum is provided with two "end plate" disks, welded on the inside:

- One drum end plate, item 2, carries the drum end roller
 - One geared motor side piece, item 3, which carries the gearbox guide roller on models SM1, SM2, and SM3
- This end plate, item 4, transfers the torque to the drum via the central drive train. The roller mountings (surfaces which guide the gearbox in the drum by means of caged rollers) are precision machined with special surface treatment to insure long service life for the drum.

4.6 Wire Rope System Components

The rope starts from a fixed point on the hoist, descends towards the bottom block, and returns to the drum. In the case of a multiple fall system, the rope runs through several sheaves before winding back onto the drum. To make certain that the wire rope take-ups on the drum correctly, the rope is locked onto the drum, the rope is guided by a rope "guide ring". On models SM1 to SM4, the guide ring, supplemented by a spring, feeds the rope onto the drum.

On a single reeved hoist, the lifting movement results in a small amount of horizontal hook drift. On a double reeved hoist, the hoist has a "symmetrical" bottom block, with 2 ropes leaving the drum, and two fixed points. The rope is raised symmetrically and does not move horizontally- thus true vertical lift. On the double reeved hoist, there are two rope guide rings.

SYSTEM COMPONENTS

- 1 Fixed point
- 2 Rope
- 3 Bottom block hook carrier
- 4 Right-hand guide ring
- 5 Left-hand guide ring
- 6 Gearbox-side drum end plate
- 7 Drum end plate, outer end side
- 8 Grooved drum (at right)

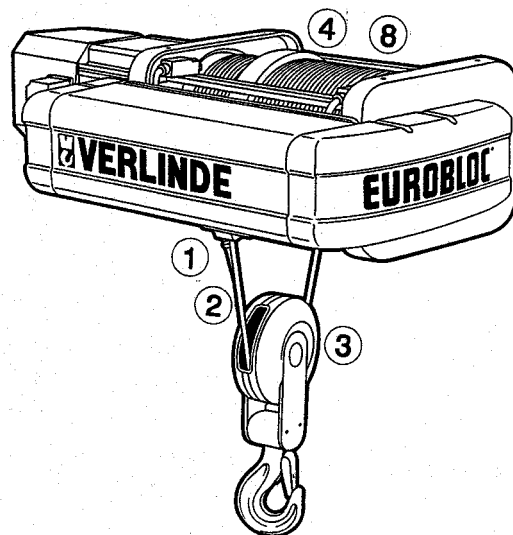

DRUM

Standard lifting hoist
(one able outlet)

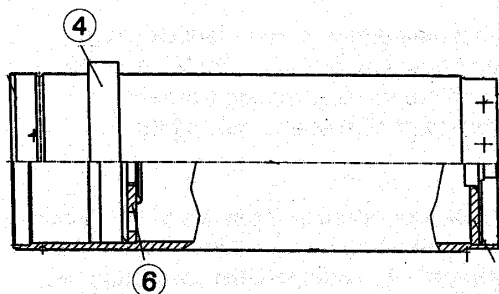

True vertical lift hoist
(two rope outlets)

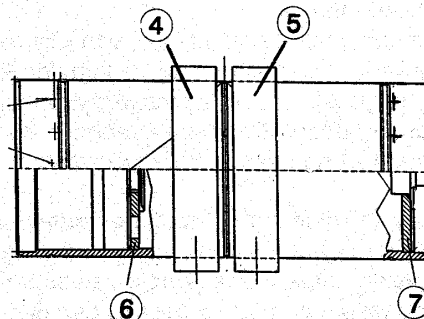

Wire Rope

The drum end of the wire rope is retained by means of 3 clamps, secured in the drum by bolts; check their tightness when carrying out any maintenance or adjustment procedures. On some special models (centered lifting), the bolts may be replaced by studs bolted into the drum (endless, adhesively bonded with LOCTITE 270), the clamps being retained by self-locking screws (or screws with locking mechanisms).

- 1 Grooved drum
- 2 Drum end side piece
- 3 "Gearbox" drum end plate
- 4 Grooved gearbox end plate (sizes 4 and 5)
- 5 Grooved borehole (sizes 4 and 5)
- 6 Toothed crown wheel
- 7 Rope guide
- 8 Standard rope attachment (3 or more per rope)
- 9 End roller
- 10 Circlips
- 11 Tappings for rope lock
- 12 Magnet (sizes 1, 2, 3)
- 13 Longitudinal drum adjustment

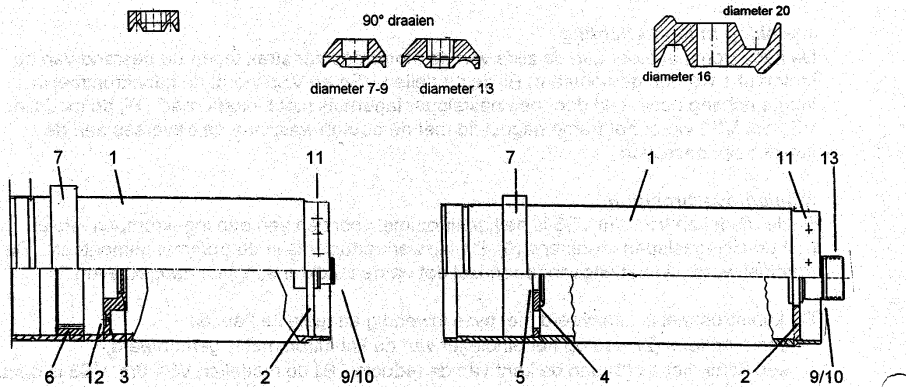

Rope attachments:

The rope(s) is/are clamped to the drum by rope attachments of a special design, WHICH CORRESPOND TO THE DIAMETER OF THE WIRE ROPE UTILIZED.

The mounting bolts are carefully tightened (see Torque Setting) and also secured by means of lock washers or adhesive (LOCTITE 243). Flat washers may not be used.

Hoist size	Number of rope attachments	Diameter of standard rope in mm.	Type of Rope attachment	Torque Screw Nm / lb-ft.	Torque Bolt	Bolt Size
Single reeved						
1	3	6	1DOO4B	20 / 14.7	X	M 8 x 25
2	3	7	UNSD OP12	40 / 29.4	X	M10 x 25
3	3	9	UNSD OP12	40 / 29.4	X	M10 x 25
4	4	13	UNSD OP12	40 / 29.4	X	M10 x 25
5	5	16	UN3 OP336	173 / 128	X	M16 x 40
Double reeved						
3	3/rope	7	RF 9 B	35 / 25.8	40 / 29.4	G 4D2004 B
4	4/rope	9	RF 9 B	35 / 25.8	40 / 29.4	G 4D2004 B
5	5/rope	13	RF 16 C	86 / 63.4	210 / 154.8	G 7D2004

The bolts are bonded with LOCTITE 270 (strong adhesive)

Wire Rope

The ropes used as standard are of the preshaped "standard lifting" or "anti-rotation lifting" type. The condition of the rope and its attachment points must be subjected to regular inspection and lubrication (see Lubrication Chart).

Guide Ring

The guide ring is made of spheroidal graphite cast iron GRP500, which is particularly resistant to wear. The two piece ring is machined with a throat for the rope locking spring and a groove to guide the rope on hoists of sizes SM1 to SM4.

These two circular halves are rejoined by using bolts, with pressure springs allowing for ease of operation of the guide during movement along the drum.

The guide ring "confines" the rope, which emerges through an aperture which points downwards (except in special cases). All the parts of a guide ring must be replaced at the same time. The rope ring is blocked against rotation by means of a guide arm, and may also support a lug element which actuates the U/L hook travel limit switches. Lubrication is provided by thorough greasing of the rope upstream and downstream of the guide, but disassembly and internal greasing are recommended in cases of intense usage or of corrosive or humid environments.

Note: All bolts must be secured against loosening (lock washers or LOCTITE 243).

See diagrams on the following pages.

GUIDE RING, size SM1

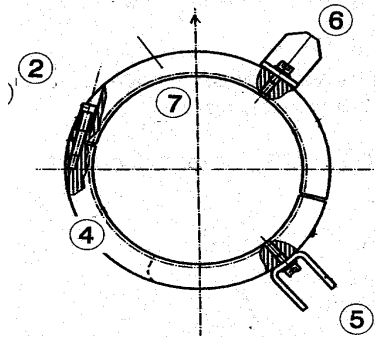

GUIDE RING, sizes SM2 and SM3

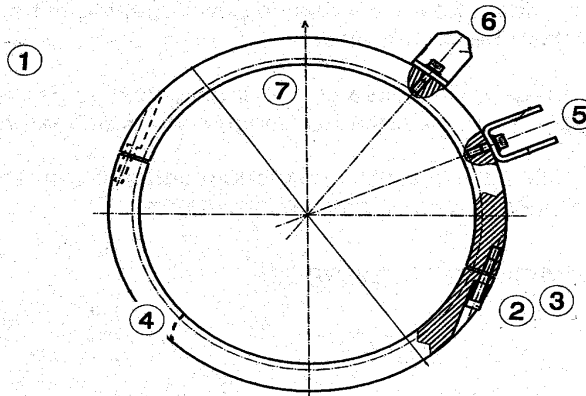

Bevestigingspunt bij vaste takel en takel in

GUIDE RING, SM 4

Fixed hoist and standard headroom hoists
TABELGELEIDER (MODEL VS4)

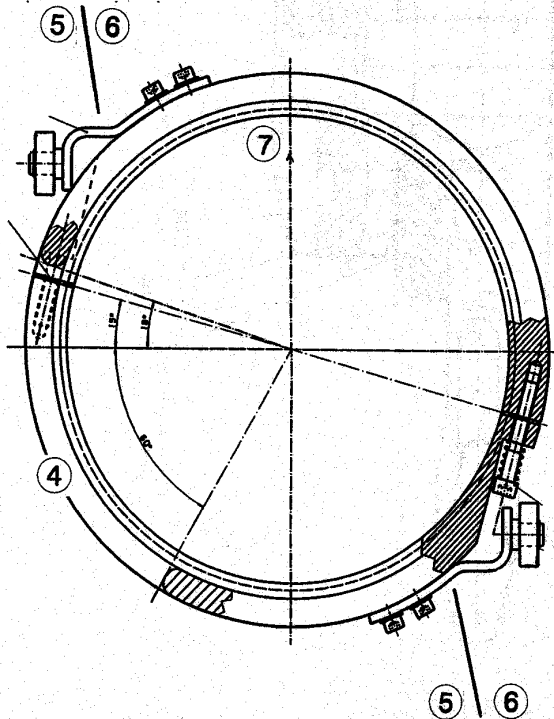

GUIDE RING, SM 5

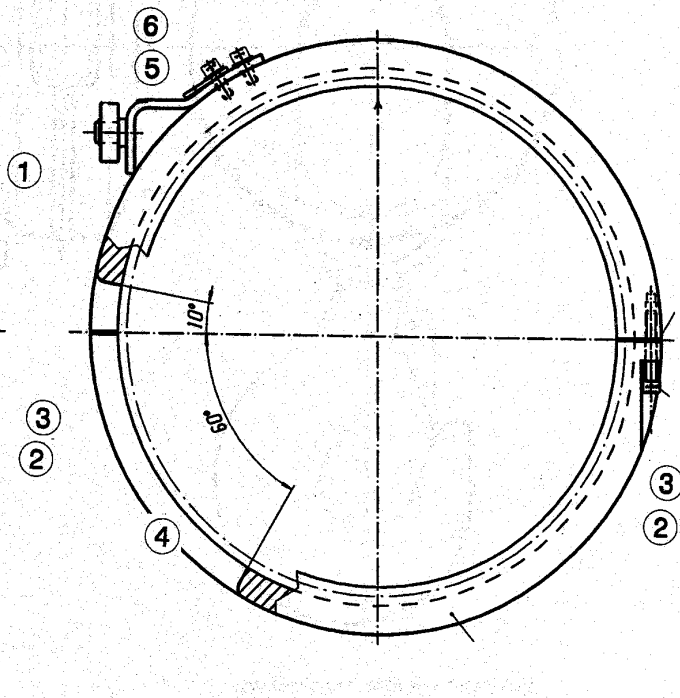

Low headroom hoist

- 1 Half guide ring
- 2 Pressure screw

- 3 Pressure spring
- 4 Rope outlet aperture

- 5 Guide arm
- 6 Limit switch actuation
- 7 Rope lock spring

Bottom Blocks Assemblies

The bottom blocks assemblies are designed in accordance with the load requirements. The hook block housing is made of forged steel except for the larger models which are steel fabrications. For low-capacity hoists, the rope outlet is protected against any contact with the rope by a high strength plastic slide element. The rated load is labeled on the side of the block assembly. The hook is supported by a crosshead piece which allows it to be inclined in addition to being rotated. Note: All bolt connections must be adhesively bonded (LOCTITE 243), with the rollers and the stop element have lubricating reservoirs.

FOUR FALL BOTTOM BLOCK ASSEMBLY

VIERPART ONDERBLOK

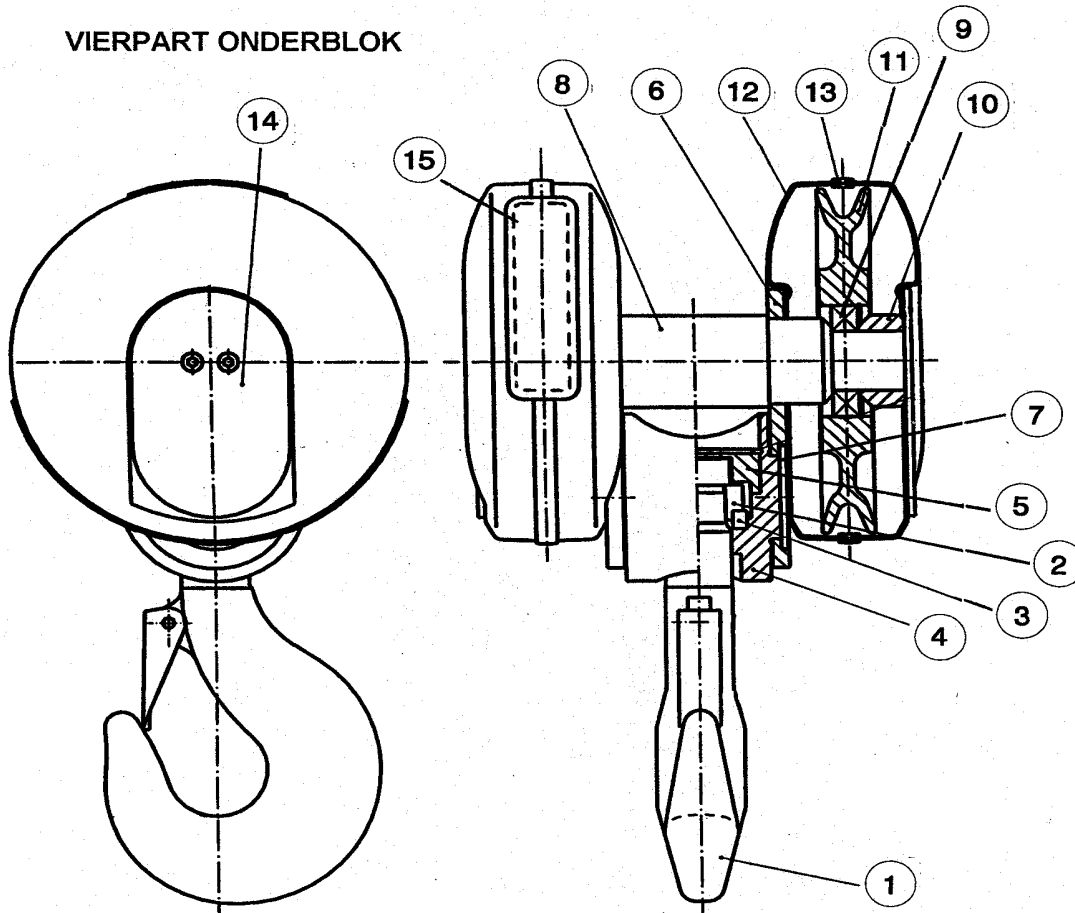

- | | | | |
|---|--------------------------|----|---|
| 1 | Hook with safety catch | 9 | Roller and circlips |
| 2 | Suspension half-parts | 10 | Centering spacer |
| 3 | Stop | 11 | Sheave |
| 4 | Cross-piece | 12 | Half-housing (except on largest models) |
| 5 | Lift prevention cover | 13 | Aluminium retaining ring |
| 6 | Suspension side plates | 14 | Assembly locking plate |
| 7 | Cross-piece locking disk | 15 | Plastic slide element (low-capacity hoists) |
| 8 | Sheave axle | | |

TWO FALL BOTTOM BLOCK ASSEMBLY

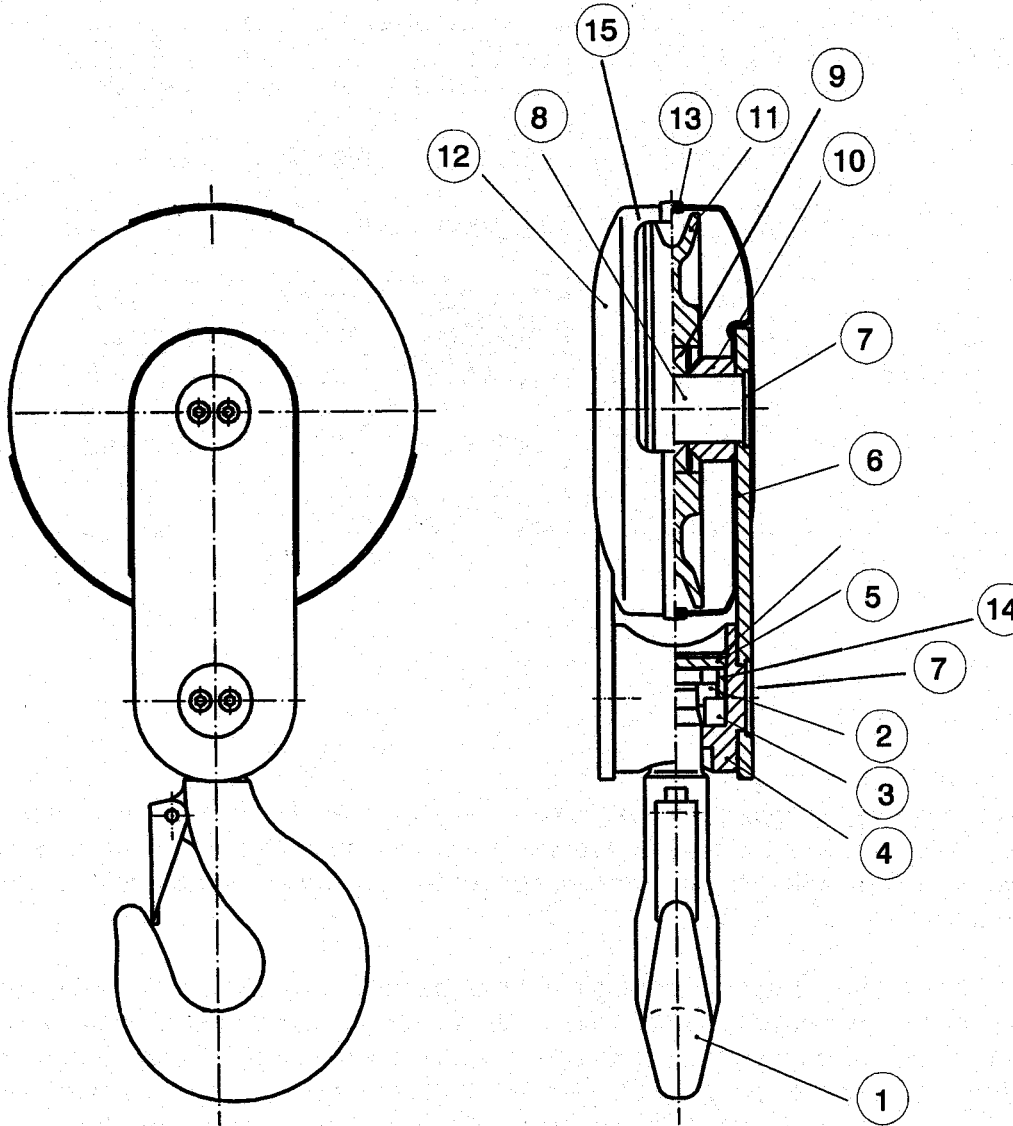

- | | | | |
|---|--------------------------|----|---|
| 1 | Hook with safety catch | 9 | Roller and circlips |
| 2 | Suspension half-parts | 10 | Centering spacer |
| 3 | Stop | 11 | Sheave |
| 4 | Cross-piece | 12 | Half-housing (except on largest models) |
| 5 | Lift prevention cover | 13 | Aluminium retaining ring |
| 6 | Suspension side plates | 14 | Safety ring |
| 7 | Cross-piece locking disk | 15 | Plastic slide element (low-capacity hoists) |
| 8 | Sheave axle | | |

Sheaves

On the same hoist, the bottom block sheaves and jackshafts (4 falls) are identical. They are made of spheroidal graphite cast iron (GGG80, surface hardness 220 HB), particularly well-suited for the friction and pressure produced by a steel wire rope. They are, however, pieces subject to wear, and require regular inspection. Ball-bearings and Roller-bearings are lubricated for life.

Hoist Model Size SM	Block 2/4 falls	Rope Diameter mm	Ext/int Diameter mm	Ext/int Diameter inches
1	2/4	6	149/119	5.87 / 4.69
	2	7	149/119	5.87 / 4.69
2	2	7	188/149.5	7.40 / 5.89
2	4	7	188/149.5	7.40 / 5.89
2				
3	2/4	9	188/153	7.40 / 6.02
3	2/4	9	266/222	10.47 / 8.74
4	2/4	13	266/221	10.47 / 8.7
4	2/4	13	330/280	12.99 / 11.0
5	2/4	16	330/275	12.99 / 10.83
5	2/4	16	421/343	16.57 / 13.5



Dead End Attachment

The wire rope dead end is attached to the hoist frame (fixed, standard headroom, double girder), or on the trolley (reduced headroom design). In the case of a 2-fall hoist, it is attached to the load limiter sub-assembly.

The use of a rope in the corner box of the fixed point is a procedure which requires care. The rope must be curved without any restraints on torsion, since this would cause the bottom block assembly to twist (with the falls "crossing"). The rope must clear the corner properly (pin). The safety calliper on the dead fall is mandatory, and during use the corner box should not be touched (except for trouble-shooting).

If the bottom block does twist, lower the block, untwist it, dismantle the fixed point (remove the rope from the box), overlap the rope to the required length (removing the curved section), and refit the rope correctly in the corner box.

Note: Before cutting a rope, the strands must be carefully bound off with the aid of fibre-reinforced adhesive tape.

On fixed points of which the axle is blocked by a bolted disk, the bolts must be adhesively bonded (LOCTITE 243). On other models, ensure that positioning is correct and that the split pin is in good condition. The fixed point and the corner box should be checked during the specified inspections.

- | | | | |
|---|------------|----|-----------------------------|
| 1 | Corner box | 6 | Rope Mounting |
| 2 | Corner | 7 | Brake Calliper on dead fall |
| 3 | Cover | 8 | Perpendicular Cover |
| 4 | Axle | 9 | Vibrating Shaft |
| 5 | Bearing | 10 | Limit Switch |

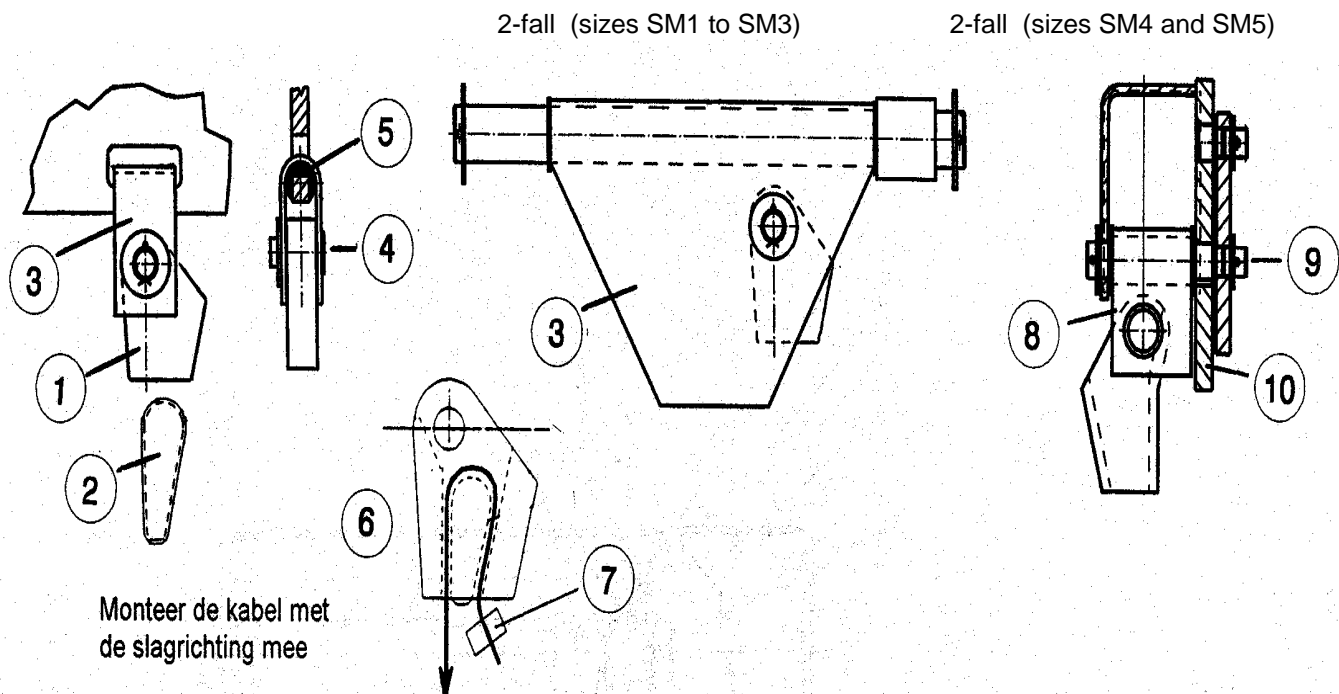

Caution : Make certain the direction of the rope is correct as displayed above

Sheave Jackshaft Assembly

Depending on the type of trolley involved, the sheave jackshaft assembly is located on a cross-member of the hoist, or on an end plate of the trolley. The longitudinal positioning of the sheave cover is important for the reliability of the load limiter device. If disassembling, be sure to mark reference points carefully for the location of the spacers and disks.

JACKSHAFT SUBASSEMBLY , Models SM1 to SM3

- 1 Jackshaft cover
- 6 Stop split-pin
- 8 Jackshaft piece
- 9 Spacer
- 10 Disk (s)
- 11/12 Sheave; size depends on capacity
- 13 Sheav axle
- 14 Roller / flat sheet joint / circlips
- 15 Stop disk
- 16 Adhesively-bonded screw

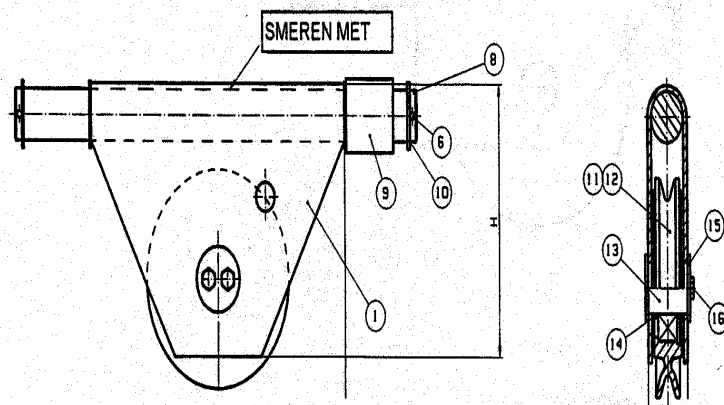

JACKSHAFT SUBASSEMBLY, models SM4 and SM5

The jackshaft shaft unit is protected by a perpendicular cover suspended by a secondary shaft. This 2nd is connected to the load limiter. This shaft allows for movement downwards of the jackshaft subassembly. The configuration varies depending on the models and the bottom blocks.

- 2 Jackshaft cover
- 3 Jackshaft piece
- 4 Stop split-pin

- 5/6 Disks/spacers
- 7 Perpendicular cover
- 32 Secondary shaft

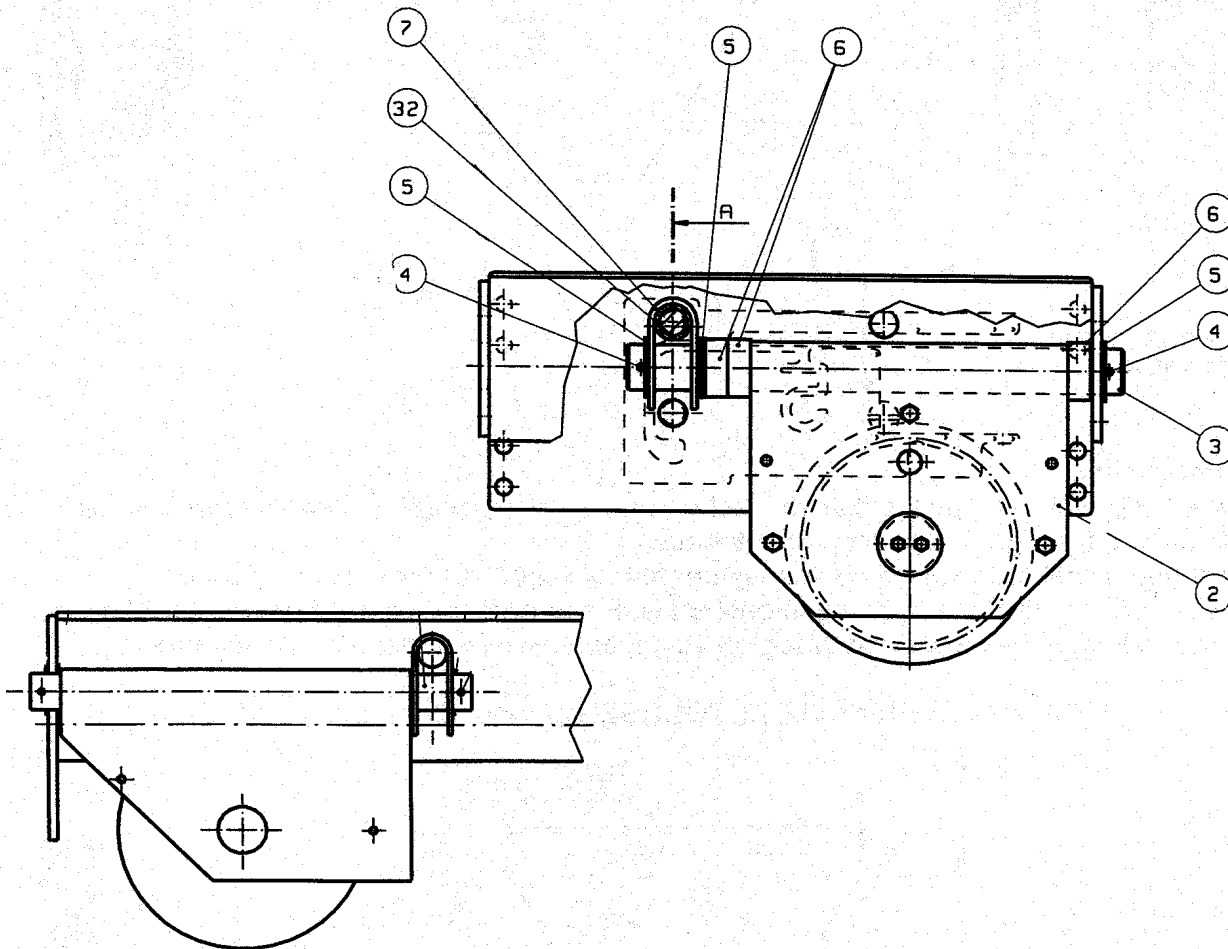

4.7 Load limiter (by means of limit switch or optional electronic monitor unit)

On hoist models SM1 to SM3, the load limiter is made up of a conical disk arrangement in a box unit which is joined to the frame. The fixed point or the jackshaft sheave exert a force downwards resulting in a small displacement downwards for the jackshaft subassembly. This movement actuates a limit switch in the event of an overload, or transmits a signal to the electronic monitoring unit (optional) by means of a "Hall" sensor. On hoist models SM4 and SM5, the load deforms a flat "spring" in the shape of a "C" or "H". This deformation creates a small movement downwards with the same consequences.

Models SM1 to SM3, load limiter (representation of the limit switch and the "Hall" sensor box).
The box is welded onto a cross-member of the frame.

- 2 Guide sleeve for the jackshaft shaft
- 4 Support plate for Hall sensor
- 7 Hall sensor box
- 9 Limit switch
- 11/12 Limit switch regulating screw
- 13 Bolted plate for movement transfer
- 14 Support disk
- 15 Conical disks, depending on load
- 18 Movement transfer at the Hall sensor
- 20 Limit approach adjustment
- 22 Rotation prevention guide bolt on shaft of Hall sensor

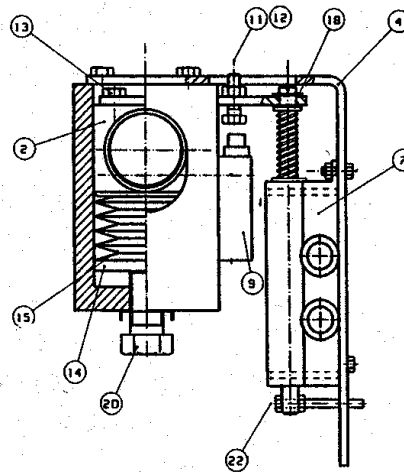

Models SM4 and SM5, limit switch (representation of limit switch and "Hall" sensor box on the flat spring and typical position on cross-member)

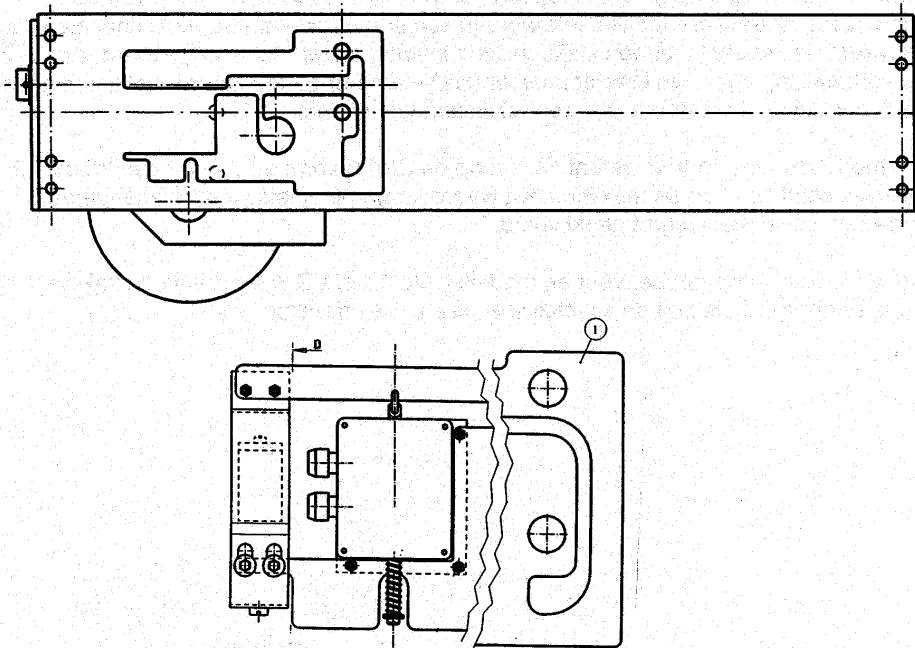

Spring "in C": 1, fitted with limit switch and Hall sensor box

4.8 Limit switches- Upper and lower travel limits

The travel of the hook is limited by a rotary limit switch which is mounted on the end of the hoist opposite the motor and gearbox assembly. The limit switch is driven by a "dog" mounted on the end of the drum. The upper travel position is set at the factory.

It is the responsibility of the Purchaser to set the lower travel setting during start-up and installation. The limit switches are safety devices. If any work is carried out on the equipment, always ensure that they are working correctly.

4.9 Trolley Drive Assembly

Your hoist is equipped with one or more trolley drive assemblies if you have a motorized trolley. The type of motor is indicated on a rating plate on the body of the motor unit. For more detailed information refer to the DS and TM Manuals.

4.10 Wheels

Double Grider Trolley Wheels - Wheel Sizes Correspond to Wheel Diameter in mm.

Note: diameter in mm. / 25.4 = diameter in inches.

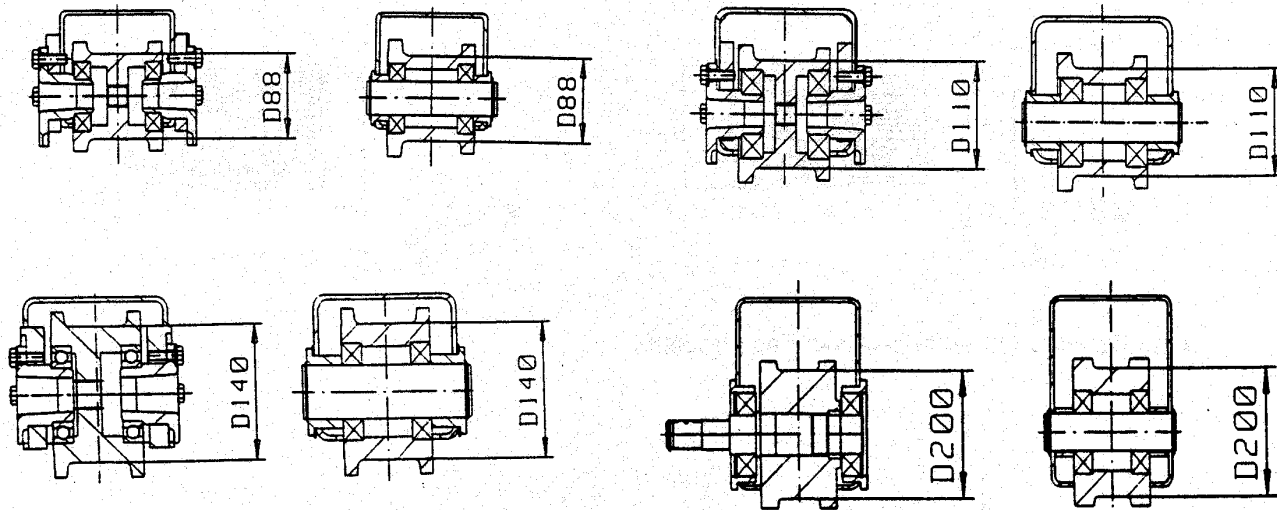

5.0 HOIST MOTORS

5.1 Description

Our hoists are fitted as standard with two-speed hoisting motor and brake assembly. The motors have cylindrical rotors and double roller bearings with nominal speeds of 3600/600 rpm. They are specifically designed for hoisting.

Motor Design Information

Performance factor is 40 % (2/3 at high speed, 1/3 at low speed).

Environmental Protection is IP55 - Near Equivalent is NEMA 3R

Insulation – Class F

Normal operating temperature is below 40 deg. C / (104 deg. F)

From 40 - 55 deg. C / (104 deg. F– 131 deg. F) HP reduced by 15 %

Motor Brake – Self-adjusting type with wear monitoring circuit

30 kW / 22.3 Hp and larger have manual adjusting brakes and fitted with a fan (single phase) and monitor circuit.

Brake Operation

Note: The power supply to the brake must be connected per the wiring diagrams and components supplied by R&M Materials Handling, Inc. (rectifier, brake controller).

Installing a motor

- Grease the coupling (refer to type of lubricant), and check direction of rotation (refer start-up).
- Carefully position the motor, ensuring that it is mounted correctly gearbox.

Replacing the motor brake assembly - Maintenance repair kits are available for brake assemblies

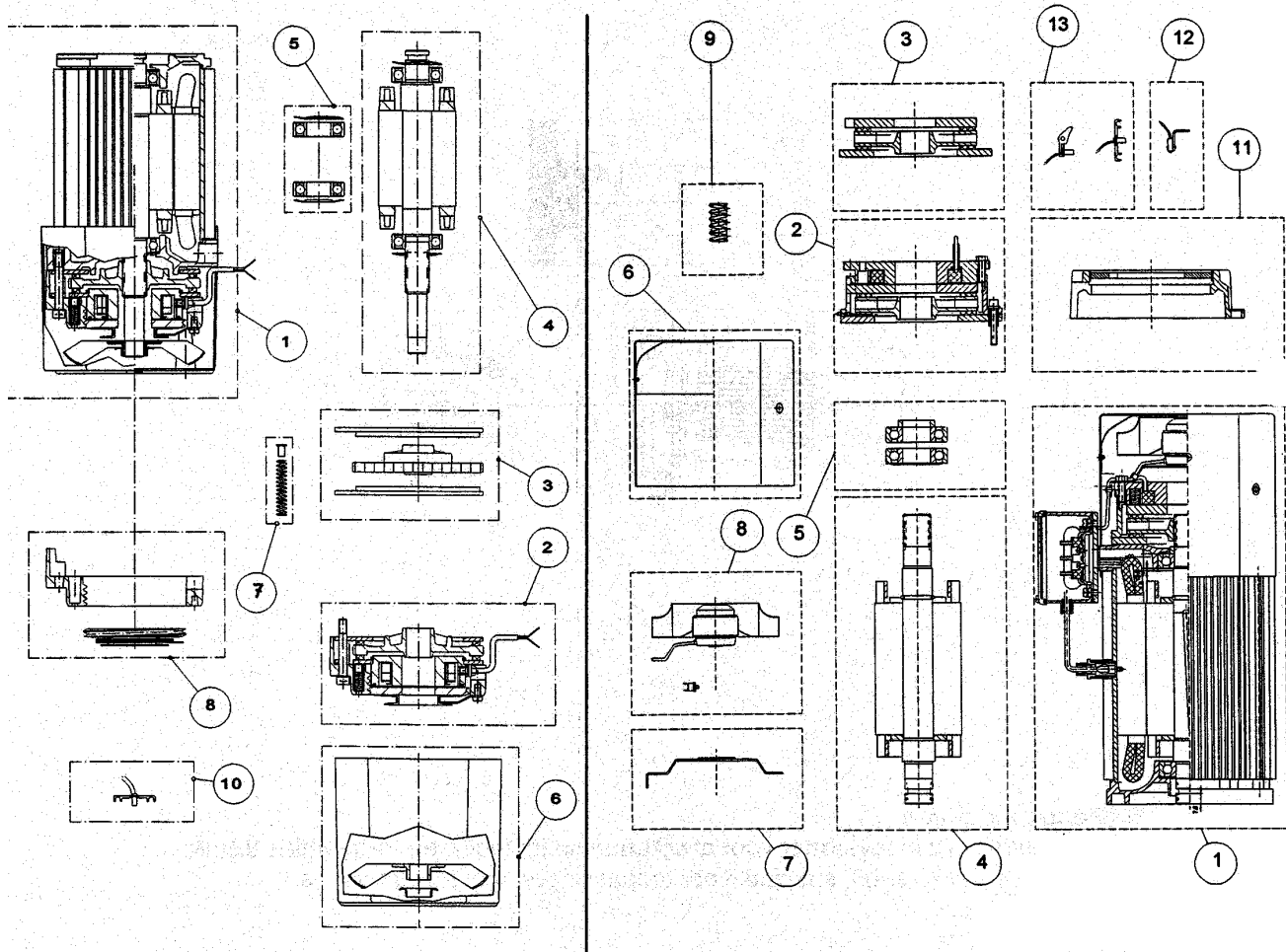

- 1) Complete motor (except for housing)
- 2) Complete brake
- 3) Disk + fittings
- 4) Complete rotor
- 5) Rollers + flexible disk
- 6) Fan
- 7) Brake spring
- 8) Automatic regulator assembly (helical spring and threaded disk)
- 9) Rectifier
- 10) Pulse counter (optional)

- 1) Complete motor (except for housing)
- 2) Complete brake
- 3) Disk + fittings
- 4) Complete rotor
- 5) Rollers
- 6) Fan, part on casing
- 7) Fan support
- 8) Electric fan and thermostat
- 9) Brake spring
- 11) Brake mounting
- 12) Microswitch and support
- 13) Pulse counter

5.2 Motor Connections

All motor leads are made per the wiring diagrams :

- Three high-speed leads
- Three low-speed leads
- Two heat sensor leads
- Two brake control leads
- Two wear loop leads

6.0 HOIST GEARBOX

Work conducted on the hoist gearcase should be carried out by experienced personnel. This work is normally restricted to lubrication. Caution: Do not underestimate the weight of the gearbox assembly during dis-assembly. When dismantling, avoid allowing any foreign materials to contaminate the gearbox assembly.

6.1 Types of Gearboxes

Hoists models SM1 to SM3 are fitted with three-train heliocoidal reduction gear boxes, lubricated by semi-liquid grease. The reduction gear is not sealed, and the drum plays the part of the casing. The actuation of the drum is effected by a pinion engaging on a toothed crown wheel, which is one piece with the drum.

Hoists Models SM4 and SM5 are fitted with two-stage reduction gears, the first of heliocoidal trains and a second epicycloidal stage. This is an oil-bath assembly, and the reduction gears are sealed units. The drum is actuated by a tapered shaft co-axial to the drum, actuating an end plate which is one piece (welded) with the drum.

5.2 Motor Connections

All motor leads are made per the wiring diagrams :

- Three high-speed leads
- Three low-speed leads
- Two heat sensor leads
- Two brake control leads
- Two wear loop leads

6.0 HOIST GEARBOX

Work conducted on the hoist gearcase should be carried out by experienced personnel. This work is normally restricted to lubrication. Caution: Do not underestimate the weight of the gearbox assembly during dis-assembly. When dismantling, avoid allowing any foreign materials to contaminate the gearbox assembly.

6.1 Types of Gearboxes

Hoists models SM1 to SM3 are fitted with three-train heliocoidal reduction gear boxes, lubricated by semi-liquid grease. The reduction gear is not sealed, and the drum plays the part of the casing. The actuation of the drum is effected by a pinion engaging on a toothed crown wheel, which is one piece with the drum.

Hoists Models SM4 and SM5 are fitted with two-stage reduction gears, the first of heliocoidal trains and a second epicycloidal stage. This is an oil-bath assembly, and the reduction gears are sealed units. The drum is actuated by a tapered shaft co-axial to the drum, actuating an end plate which is one piece (welded) with the drum.

GEARBOXES SM1 to SM 3:

The alignment of the reduction gear on the drum is effected by a vibrating roller and a roller cage.

- 1 Motor securing bolt
- 2 Reduction gear securing bolt
- 3 Reduction gear securing plates
- 5 Reduction gear sealing joint
- 6 Drum roller cage
- 7 Plastic sleeve
- 8 Primary shaft
- 9 Coupling
- 10 Torque joint
- 11 Greasing aperture
- 12 Drum seal
- 13 Plug
- 14 Drum
- 15 Lubricant
- 16 Rotation reference marking (coupling direction reference marking)

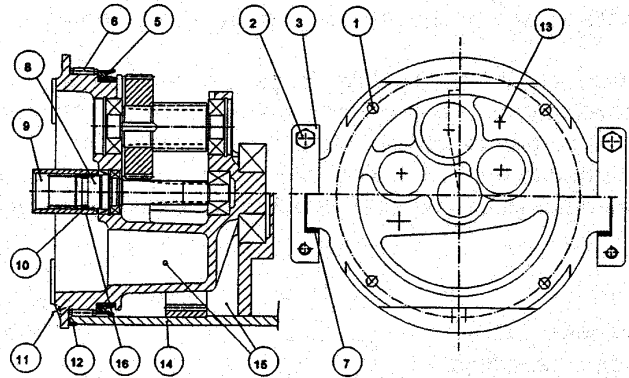

GEARBOXES SM4 and SM5:

The alignment of the reduction gear on the drum is effected by two roller cages.

- 1 Motor securing bolt
- 2 Securing bolt
- 3 Securing plates
- 4 Roller cage
- 7 Plastic sleeve
- 6 Primary shaft
- 7 Coupling
- 8 Torque joint
- 9 Greasing aperture
- 10 Drum seal
- 11 Magnetic plug
- 12 Breather plug
- 13 Inspection glass
- 14 Seal
- 15 Tapered shaft
- 16 Securing bolt
- 17 Securing bolt
- 18 Drum
- 19 Rotation reference marking (coupling direction reference marking)

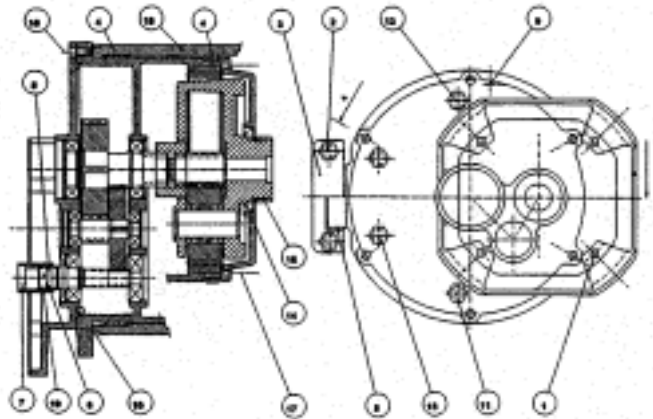

6.2 Disassembly – Re-assembly

Connections

A disassembly/assembly operation may be necessary during inspections or lubrication procedures. The person carrying out the work must act with care to ensure that the reduction gear unit is correctly aligned in its housing, without using force, and is engaged with the actuation crown wheel and/or the drum end plate (teeth/splines transferring the torque).

Dismantling

Dismantle the motor. Raise the greasing cover to allow the admission of air when the reduction gear unit is lifted out. Take off the maintenance panels and carefully disconnect the reduction gear unit.

Note: On open reduction gear units (sizes SM1 to SM3), grease may run out during disassembly.

Inspection/reassembly

Check carefully to ensure that no foreign bodies have penetrated into the open reduction gear units, or are present on the roller supports or the splines; wipe off the old grease, and clean the magnets and breathers.

Grease (see "lubricants") the roller supports, the coupling sleeve (all models), and the splines (sizes 4 and 5).

Check for oil leaks (size 4, 5), and, if necessary, change the casing joints.

Check or replace sleeves made of synthetic materials, and carefully secure the reduction gear/sleeve/receptacle assembly. Carefully reposition it, without using force. The high-speed shaft may be turned by hand to facilitate alignment. Check the assembly before refitting the motor; position the unit, lock the maintenance panels, and apply adhesive bonding. Test the operation of the hoist.

Fixation of reduction gear unit/sleeve/end plate

The reduction gear unit is secured to the body by means

of two bolted plates. This link is semi-rigid, rendered flexible

by a pair of sleeves made of synthetic material, and the presence of which is essential.

The person carrying out the work must ensure that these sleeves are properly set in their receptacle.

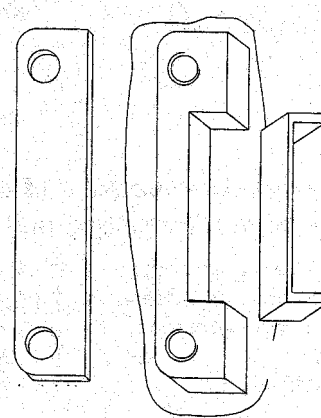

Scratch

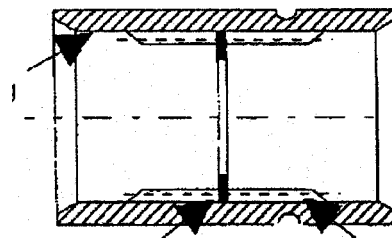

Toric joint support

Motor side

Reduction gear side

Circlips

Splines

Motor / gearbox coupling

On the motor side, the connection is established with the aid of a tapered spline (lubricated), the direction of installation of which must be respected.

Lubrication and lubricants

See relevant section.

6.3 Gearbox Inspection

During an inspection, the first step, before any disassembly work, is to ensure that no abnormal noise is occurring when idling or under load.

After dismantling, a visual check is made (sizes 1, 2, 3) for the absence of any signs of unusual wear, excessive quantities of particles on the magnets, and absence of fretting (marked points or scratches) on the teeth. The high-speed train is moved by hand to ensure the absence of any hard points or excess lay. In case of doubt, the reduction gear unit should be replaced in its entirety; remember that the reduction gear unit is designed for the theoretical service life of the hoist (and therefore up to the general inspection; see "S.W.P."), but instances of premature wear are possible, depending on the conditions of use.

- Remove old grease
- Clean magnets and breathers
- Replace sleeves of synthetic material
- Replace reduction gear unit/drum joint
- Change lubricants

7.0 HOIST MAINTENANCE

7.1 General

Your equipment should be provided with maintenance and repairs like any other machine. Certain inspections should be carried out on a regular basis (the frequency depends on the rate at which the equipment is used). Others inspections are associated with a general inspection. Equipment which is used sporadically, or under specific conditions (humidity, corrosive environment, etc.) will likewise be the object of other checks.

Inspections and maintenance must be performed by qualified personnel. Preventive maintenance provides for long service life and ensures "operational safety".

The electronic control unit calculates, automatically, the activity of the hoist and is a practical preventive maintenance tool.

In addition, certain components are to be replaced on a systematic basis (column D(h), marked X on the table below), while others will be replaced annually.

Parts subject to wear

Certain components (mechanical and electrical) are subject to wear. It is recommended to maintain a stock of key components if the application requires quick restoration to service.

FACTORY RECOMMENDED MAINTENANCE SCHEDULE

" x " - indicates frequency of recommended action

Note: This Schedule is to be used only as a guide. The End User is the best judge of the actual use and the conditions under which the hoist has been operating. Experience will dictate variations from below suggestions.

Duty Class	Scheduled maintenance periods - calendar schedule						Notes
H3 or less	1 month	6 mo.	1 year	4 years	8 years	Replace	
H4 or greater	2 weeks	3 mo.	6 mo.	2 years	4 years		
WIRE ROPE							
Visual	X						
Detailed inspection			X				
Greasing (lubricant 4)		X					
Replacement						X	Depends on condition
HOISTING BRAKE							
Operation	X		X				
Check gap			X				
Visual inspection			X				
Cleaning				X			
Replacement by kit						X	Depending on wear
GUIDE RING							
Inspection		X					
greasing		X					
Replacement of rope guide						X	Depending on wear
Replacement of long spring			X			X	Depending on wear
HOIST GEARBOX							
Inspection					X		
Greasing					X		
Synthetic material sleeve				X			
Replacement						X	Depending on wear
COUPLING							
Inspection				X			
Greasing				X			
Synthetic material sleeve				X			
Replacement						X	Depending on wear
TROLLEY							
Bolt tightness		X	X			X	
Check Wheel wear		X	X				
Check Wheel roller bearings			X				
Greasi pinions (lubricant 4)		X	X				
Play on rail 3/5 mm		X	X				
GEAR/ DRUM BEARING							
Lubrication				X		X	
Inspection				X		X	
Replacement					X		
Red. gear/drum movement					X		
DRUM							
External Wear			X				
Roller Mount Wear					X		

R&M Materials Handling, Inc. reserves the right to alter or amend the above information without notice.
Document : SM2000-01

FACTORY RECOMMENDED MAINTENANCE SCHEDULE

" x " - indicates frequency of recommended action

Note: This Schedule is to be used only as a guide. The End User is the best judge of the actual use and the conditions under which the hoist has been operating. Experience will dictate variations from below suggestions.

Duty Class	Scheduled maintenance periods - calendar schedule						Notes
H3 or less	1 month	6 mo.	1 year	4 years	8 years		
H4 or greater	2 weeks	3 mo.	6 mo.	2 years	4 years		
LIMIT SWITCHES							
Operation		x	x				
Replacement				x		x	
ROPE ATTACHMENT							
Tightness		X	X				
CABLE DEAD END							
Visual + positioning		X	X				
No anomalies tolerated							
Replacement				X		X	
SHEAVES							
Visual + rotation		X	X				
Degree of wear			X			X	
HOOK							
Visual (+ catch)		X	X				
Measurement of nose		X	X				
Hook tail			X				
Check thrust bearing			X				
Replacement						X	Opened, shock, wear
FRAME							
Visual			X				
Bolt tightness			X				
HOISTING MOTOR							
Visual + noise		X	X				
CONTROLS							
Visual + operational		X	X				
Suspension elements		X	X				
TROLLEY DRIVES							
Level of noise + visual							
Inspection							
Max. pinion play 0.6 mm / 0.024 in.							
Greasing (interior)							
Check brake wear							
LOAD LIMITER							
Visual		X	X				
Calibration/setting			X			X	
ELECTRONIC UNIT							
Data assessment						X	

7.5 Lubrication

Lubrication operations should be carried out by experienced and qualified personnel.

The hoist components to be lubricated are:	LUBRICANT	QUANTITY
- Hoist reduction gear, hoists 1		1 0.30 L
- Hoist reduction gear, hoists 2 & 3		1 0.55 L
- Hoist reduction gear, hoists 4 (except Low Hd Rm)		2 1.40 L
- Hoist reduction gear, hoists 4 (Low Hd Rm only)		2 2.00 L
- Hoist reduction gear, hoists 5		2 2.2 L
- Direction reduction gear, GS3		6 0.35
- Direction reduction gear, GS4		6 0.70
- Motor/reduction gear couplings		3 Contact
- Reduction gear/drum splines		4 Contact
- Motor gear teeth		4 Contact
- Roller bearings		5 Contact
- Hoist Wire rope		4 Surface
- Wire Rope Guide Ring		4 Contact

The following lubricants have been selected on the basis of endurance tests:

1- Semi-fluid grease, high performance FUCHS Renax gls00 MOBIL SCH 007	2- Oil for hoist reduction gear BP Energol XP220 ESSO Spartan EP 150/220 NESTE Vaihde 150 EP SHELL Omala 150/220
3- High-density grease, adherence/high pressure FUCHS Renolit FLM2	4- Dense grease for pinions MOBIL Mobilplex 48 BP Energol GR3000-2 ESSO Surett F 4k SHELL Kuggfett
5- Roller bearing grease BP Energrease LS2 TB Multi purpose ESSO Beacon EP2	6- Direction reduction gear grease FUCHS renolit duraplex EP00 MOBIL Mobilux EP004

Contact the Factory for specific applications ("extreme cold") so that an appropriate lubricant may be recommended. During routine maintenance operations, only the lubrication of reduction gear roller cages is scheduled. The replacement of the reduction gear lubricant should be carried out every four years during inspections.

Changing hoist reduction gear lubricant, types 1, 2, and 3 (semi-fluid grease):

- This operation is ideally carried out with the "drum vertical"
- Remove the motor
- Remove the reduction gear securing plates
- Lift off the grease lubricator
- Clamp the drum
- Take off the drum reduction gear. CAUTION: Grease will flow freely out of the reduction gear / drum
- Clean the pinions and drum, and carefully clean the drum magnets
- Inspect and lubricate (5) the reduction gear / drum rollers
- Top up with new grease (1) (see type and quantity)
- Grease the roller bearings and the joint (3)
- Reinstall the reduction gear, making sure that the vibrating roller is correctly aligned and primary shaft turns.
- Retighten the securing plates (apply adhesive to the bolts, LOCTITE 243)

Changing hoist reduction gear lubricant, types 4 and 5 (oil):

- Release the motor
- Release the magnet drain plug, empty the reduction gear, and clean the magnet
- Release the valve plug and clean it
- Replace magnet plug
- Top up with new oil (2) (see type and quantity)
- Replace valve plug

Changing lubricant, direction reduction gear(s):

- These units are normally lubricated for life.
- Remove the trolley drive assembly from the hoist. Next remove the motor from the trolley drive.
- Open the reduction gear, clean it carefully, and inspect pinions and bearings
- Grease (see type and quantity)
- Close and reinstall (pay attention to alignment, and do not force the positioning procedure with the help of the bolts)

7.6 Wire Rope

CAUTION: A wire rope hoist should never be used if the wire rope shows any evidence of mechanical damage or excessive wear.

Replacement must be made using a wire rope of exact size, quality, and fittings with which your hoist was originally equipped from the factory.

Improper wire rope storage or installation procedure can render the wire rope unusable prior to the first lift.

Wire rope inspection should be conducted monthly by a designated, qualified person using good judgment in evaluating the remaining service life. Any deterioration of the wire rope resulting in appreciable loss of the original strength, such as situations described below, should include a written report, dated and signed by the inspector.

- 1) Improper lubrication of wire rope
- 2) Worn outside wires.
- 3) Broken or corroded wires at the end connections.
- 4) Crushing, slicing, unstranding, or kinking.
- 5) Internal wear caused by grit penetrating the strands.
- 6) Broken outside wires and the concentration of such wires.
- 7) Reduction of original rope diameter.
- 8) Damaged, worn, or improperly applied end connections.
- 9) Birdcaging.

WARNING: Also evaluate those sections which are normally hidden during inspections, such as sections which pass over equalizer sheaves.

CAUTION: Wear gloves whenever handling wire rope.

The wear life of the wire rope depends mainly upon the frequency and severity of service and its maintenance. All wire rope will eventually deteriorate to a point where it is no longer serviceable or safe.

No precise rules can be given for determination of the exact time for replacement of the wire rope because of the many factors involved. Any one of the following conditions is sufficient reason for replacement.

- 1) Twelve randomly distributed broken wires in any one rope lay, or four broken wires in any one strand in one rope lay.
- 2) Wear of one-third of the original diameter of individual outside wires.
- 3) Kinking, crushing, birdcaging, or any damage from any cause.
- 4) Evidence of any heat damage from any cause.
- 5) Reductions from nominal diameter of more than:
 - 1/64" for diameters up to and including 5/16"
 - 1/32" for diameters 3/8" to 1/2" inclusive
 - 3/64" for diameters 9/16" to 3/4" inclusive
- 6) The development of 2 broken wires adjacent to a socketed or swaged fitting, or signs of corrosion at that point.

The correct diameter of a wire rope is the diameter of a circumscribed circle which will enclose all the strands. It is the largest cross-sectional measurement when using calipers. The measurement of the rope diameter on a new hoist or a replacement cable should be recorded for reference during future inspections.

Please follow the generalized reeving instructions located in the the earlier section (Wire Rope System Components).

- 1) Hoisting ropes as furnished on new hoists or as a service part from R&M Materials Handling are of special construction, designed specifically for hoist applications. It is recommended that replacement cables with necessary end fitting be obtained from an authorized R&M Materials Handling Parts Dealer. Use of non-authorized wire rope may seriously shorten the life of the rope and void the warranty of a new hoist.
- 2) When unreeling a new replacement wire rope, roll out the cable on the floor. Do not attempt to uncoil because this will result in kinking the cable.
- 3) Depending on the operating conditions, lubrication of the wire rope is sometimes desirable, and is best achieved by pulling the rope through an oiled tissue (preferably heated oil). The rope can be left unlubricated but should be inspected more often than normal since its service life will be decreased. Refer to Lubrication Schedule for proper lubricant.
- 4) Make sure replacement wire ropes are properly reeved through sheaves and bottom block assembly.
- 5) Any new or replacement wire rope when first installed may cause the bottom block to turn or twist when a load is applied, resulting in the hoist cables twisting around each other. To correct, run the bottom block to the floor and disconnect the wire rope at the end anchor on the hoist frame (or wire rope clamps on each end of the drum for double reeving). Twist the end of the wire rope several revolutions in the direction opposite of the block twist and reconnect. Run empty bottom block up and down a few times to stabilize wire rope twist. It may be necessary to repeat more than once during the first few days of hoist operation with new wire ropes.

A.0 APPENDIX

The equipment is equipped with a time counter and a load limiter. It is recommended user keep a on-going record of the operating time and the loads. The cumulative time can be compared to the time on the counter. The actual use is evaluated and compared to the counter during the annual inspection

A.1 Replacement Criterial for Wire Ropes

Please refer to OSHA 29CFR1910 and for wire rope inspection and replacement requirements.

A.2 Replacement Criterial for Wheels

The wheels must be replaced if the amount of play indicates a noticeable degree of wear, or if wear on the rolling surface has reached the following limits:

Monorail trolley		Double girder trolley	
Nom. dia. (mm) / in.	Dia. Min. (mm) / in.	Nom. dia. (mm) / in.	Dia. Min. (mm) / in.
(100) / 3.94	(97) / 3.82	(100) / 3.94	(97) / 3.82
(125) / 4.92	(120) / 4.72	(140) / 5.51	(135) / 5.31
(160) / 6.30	(155) / 6.10	(160) / 6.30	(155) / 6.10
		(200) / 7.87	(195) / 7.68
		(250) / 9.84	(245) / 9.65

A.3 Replacement Criterial for Sheaves

Rope dia. D (mm)	Sheave type	Width B inches	Width B mm.	Radius R inches	Radius R mm.	Sheave dia. d inches	Sheave dia. d mm.	d min. inches	d min. (mm)
6	2P1000A	1.18	30	0.145	3.7	4.69	119	4.53	115
6	2P2000A	1.18	30	0.145	3.7	5.89	149.5	5.63	143
7	2P1000A	1.18	30	0.145	3.7	4.69	119	4.53	115
7	2P2000A	1.18	30	0.145	3.7	5.89	149.5	5.63	143
9	3P1000A	1.18	30	0.189	4.8	6.02	153	5.87	149
9	3P2000A	1.34	34	0.189	4.8	8.74	222	8.27	210
9	4P4000B	1.50	38	0.189	4.8	8.74	222	8.27	210
13	4P1000A	1.50	38	0.276	7	8.70	221	8.50	216
13	4P2000A	1.81	46	0.276	7	11.02	280	10.83	275
13	5P3000A	1.50	38	0.276	7	8.70	221	8.50	216
13	5P4000A	1.81	46	0.276	7	11.02	280	10.83	275
13	6P3000A	1.50	38	0.276	7	8.70	221	8.50	216
13	6P4000A	1.81	46	0.276	7	11.02	280	10.83	275
14	P7C0011	1.81	46	0.335	8.5	10.83	275	10.63	270
14	P7S1010	1.81	46	0.335	8.5	13.54	344	13.31	338
16	5P1000A	1.81	46	0.335	8.5	10.83	275	10.63	270
16	5P2000A	2.28	58	0.335	8.5	13.50	343	13.27	337
16	P7C0011	1.81	46	0.335	8.5	10.83	275	10.63	270
16	P7S1010	1.81	46	0.335	8.5	13.54	344	13.27	337
20	6P1000A	2.28	58	0.433	11	13.82	351	13.58	345
20	6P2000A	2.56	65	0.433	11	16.85	428	16.61	422

