

# CHESTER HOIST

"Performance Plus Flexibility"



## ZEPHYR ARMY TYPE TROLLEY HOIST

The equipment illustrated and described in this bulletin is designed for manual operation only and is not to be power driven, nor is it suitable for lifting people or for handling molten metal. It is fabricated in accordance with ANSI B-30.16 and HMI 200.

**1/2 to 2 TON.** Zephyr Army Trolley hoists in these capacities are notable for light weight and ability to traverse minimum radius curves freely, since the trolley units swivel. Construction is ingeniously simple. A standard Zephyr spur geared hoist is suspended on a special load bar carried at each end by a lifetime lubricated precision ball bearing-equipped two wheel trolley. Trolley units are adjustable to beam size and are interchangeable. Plain trolley may be replaced with geared unit at any time, as required. Wheels have convex-machined treads that will maintain roundness through long use.

**3 to 10 TON.** These units are compact combinations of the larger-capacity Zephyr spur geared hoists with integrated four-wheel trolleys with duo-sealed Timken-bearings. The result is a unit of minimum dimensions retaining full operating advantages. Modified conventional Army Type construction not only provides protection of heavy gauge rolled steel side plates, but also added advantages of adjustability to beam sizes, as well as adaptability to comparatively tight minimum radius track curves. All trolley wheels are easily adjustable for bearing wear.

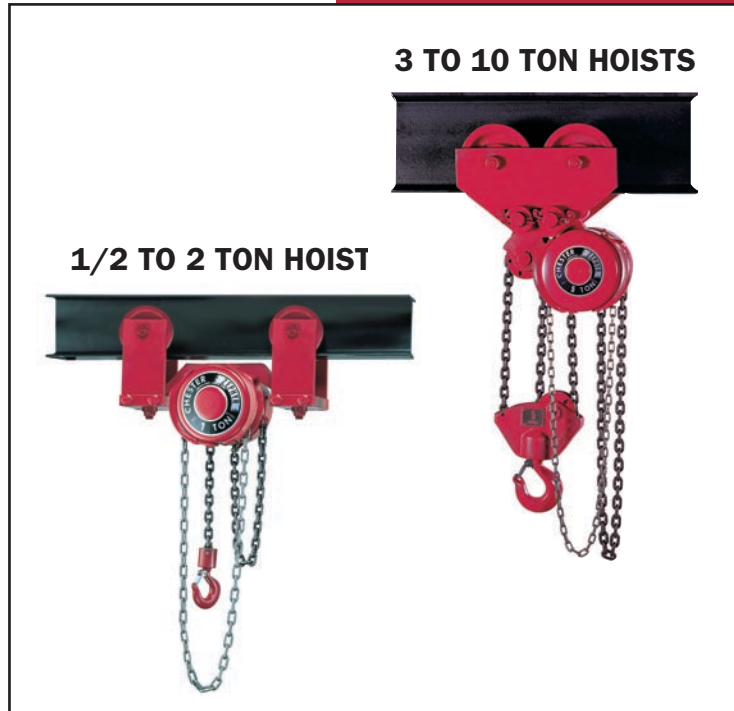

CATALOG NUMBER		CAPACITY TONS	STANDARD LIFT, FEET	MINIMUM HEADROOM	MINIMUM RADIUS CURVE **	ADJUSTABLE FOR STANDARD I-BEAM *	WEIGHT IN POUNDS			
							NET		GROSS	
PLAIN	GEARED						PLAIN	GEARED	PLAIN	GEARED
1311 - 1/2	1312 - 1/2	1/2	8	10 3/4"	21"	S4" - S10" x 25.4#	94	139	115	160
1311 - 1	1312 - 1	1	8	10 7/8"	21"	S5" - S10" x 25.4#	109	145	130	164
1311 - 1 1/2	1312 - 1 1/2	1 1/2	8	13 1/2"	30"	S6" - S15" x 42.9#	169	194	208	240
1311 - 2	1312 - 2	2	8	13 1/2"	30"	S6" - S15" x 42.9#	169	194	208	240
1311 - 3	1312 - 3	3	8	19 5/8"	36"	S8" - S18" x 54.7#	220	260	246	300
1311 - 4	1312 - 4	4	8	20 1/8"	36"	S8" - S24" x 90#	274	295	300	340
1311 - 5	1312 - 5	5	8	23 1/2"	48"	S10" - S20" x 66#	375	400	405	445
1311 - 6	1312 - 6	6	8	23 1/2"	48"	S10" - S20" x 66#	375	400	405	445
1311 - 8	1312 - 8	8	8	24 5/8"	84"	S10" - S24" x 121#	523	563	558	605
1311 - 10	1312 - 10	10	8	25"	90"	S12" - S24" x 121#	673	703	725	773

Zephyr Army Type Hoists are available for wide flange sections, monorail runways, or I-beams outside the normal adjustment range. Consult factory for details.

**Chester Hoist**  
**Lisbon, Ohio U.S.A. 44432**  
**Phone (330) 424-7248**  
**Fax (330) 424-3126**  
**Email chhoist@valunet.com**

\*Beams listed are for proper wheel clearance only. The customer must verify his selected beam is adequate for his application.  
 \*\*Radius must be specified on each order. Wheels may require modification for some curves.

## Bulletin B

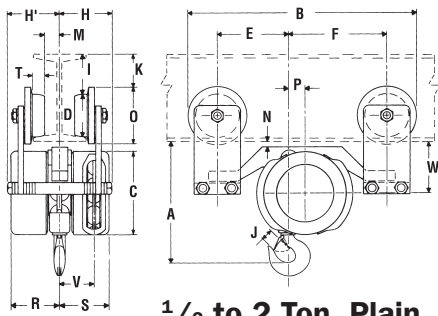

**1/2 to 2 Ton, Plain**

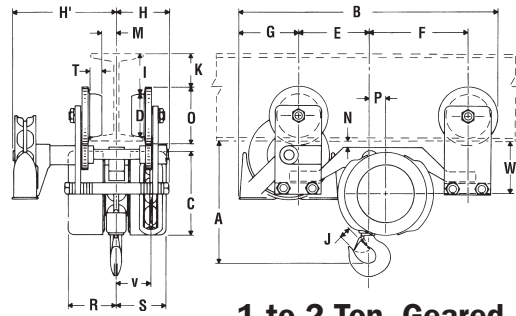

**1 to 2 Ton, Geared**

**PLAIN**

CAP IN TONS	ALL DIMENSIONS SHOWN IN INCHES																				
	A	B	C	D	E	F	H	H'	I	J	K	L	M	N	O	P	R	S	T	V	W
1/2	10 7/8	18 3/8	7 1/4	2 7/8	6 1/8	8 5/8	4 1/4	-	13/16	1	7/16	-	1/2	5/8	3 5/8	1 3/8	4 1/4	4 1/4	7/8	3	4 9/16
1	10 7/8	19 3/4	7 1/4	3 3/4	6 1/8	8 5/8	4 5/8	-	15/16	1	5/16	-	1/2	5/8	5	1 3/8	4 1/4	4 1/4	1 1/16	3	4 9/16
1 1/2	13 1/2	24 1/2	9 3/4	4 1/2	7 1/2	11	5	-	1	1 1/8	5/16	-	11/16	7/16	6	1 3/4	5	5	1 7/64	3 1/4	5 7/16
2	13 1/2	24 1/2	9 3/4	4 1/2	7 1/2	11	5	-	1	1 1/8	5/16	-	11/16	7/16	6	1 3/4	5	5	1 7/64	3 1/4	5 7/16

**GEARED**

CAP IN TONS	ALL DIMENSIONS SHOWN IN INCHES																				
	A	B	C	D	E	F	G	H	H'	I	J	K	M	N	O	P	R	S	T	V	W
1	10 7/8	22 1/2	7 1/4	3 3/4	6 1/8	8 5/8	5 1/4	4 13/16	8 5/8	15/16	1	5/16	1/2	5/8	5	1 3/8	4 1/4	4 1/4	1 1/16	3	4 9/16
1 1/2	13 1/2	27 1/4	9 3/4	4 1/2	7 1/2	11	5 3/4	4 9/16	8 7/8	1	1 1/8	5/16	11/16	7/16	6	1 3/4	5	5	1 7/64	3 1/4	5 7/16
2	13 1/2	27 1/4	9 3/4	4 1/2	7 1/2	11	5 3/4	4 9/16	8 7/8	1	1 1/8	5/16	11/16	7/16	6	1 3/4	5	5	1 7/64	3 1/4	5 7/16

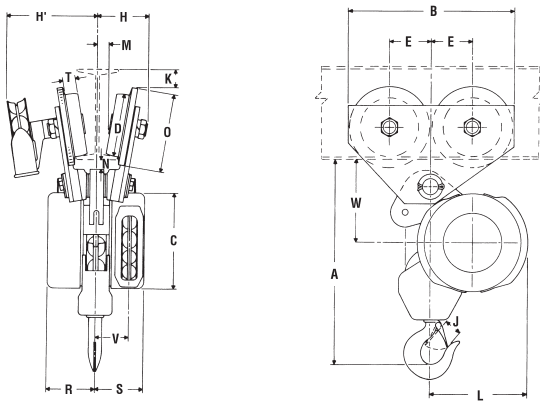

**3 and 4 Ton, Plain & Geared**

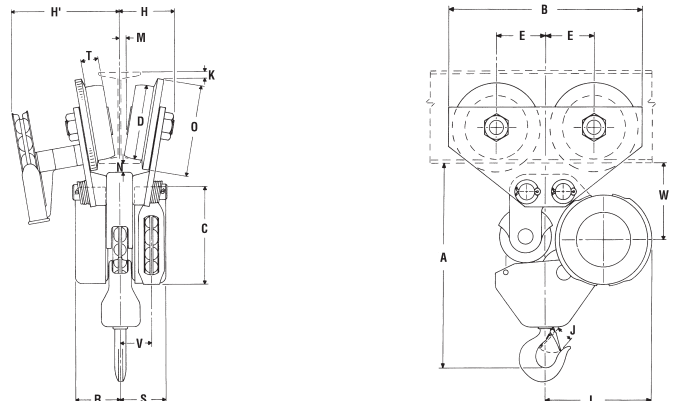

**5 and 6 Ton, Plain or Geared**

CAP IN TONS	ALL DIMENSIONS SHOWN IN INCHES																				
	A	B	C	D	E	F	H	H'	I	J	K	L	M	N	O	P	R	S	T	V	W
3	19 5/8	16 3/4	9 3/4	6 3/8	4 1/4	-	5 1/8	11	-	1 11/32	5/8	11	3/4	1 1/8	8	-	5	5	1 5/16	3 1/4	8 1/4
4	20 1/8	16 3/4	9 3/4	6 3/8	4 1/4	-	5 1/8	11	-	1 11/16	5/8	11	3/4	1 1/8	8	-	5	5	1 5/16	3 1/4	8 1/4
5	23 1/2	19 1/2	9 3/4	7 3/16	5	-	5 3/4	13 1/16	-	1 11/16	1 5/8	11 7/8	1 1/8	1	9	-	5	5	1 7/16	3 1/4	8 5/8
6	23 1/2	19 1/2	9 3/4	7 3/16	5	-	5 3/4	13 1/16	-	1 11/16	1 5/8	11 7/8	1 1/8	1	9	-	5	5	1 7/16	3 1/4	8 5/8

For 3 thru 10 Ton, dimensions H, H' and K vary directly as the beam varies.

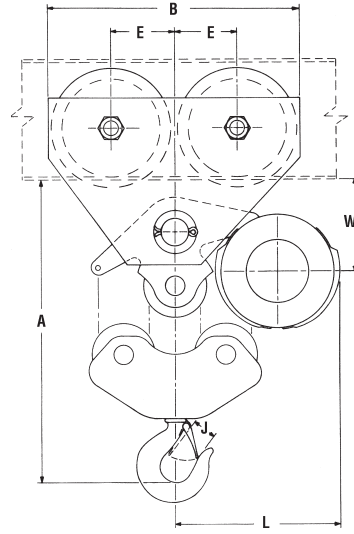
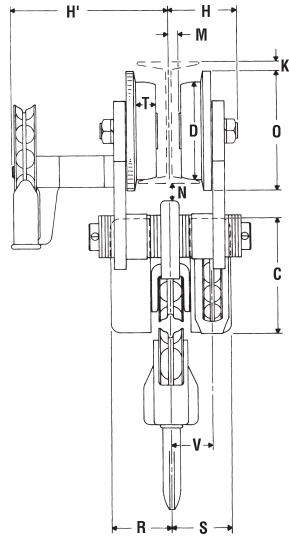

**8 Ton, Plain or Geared**

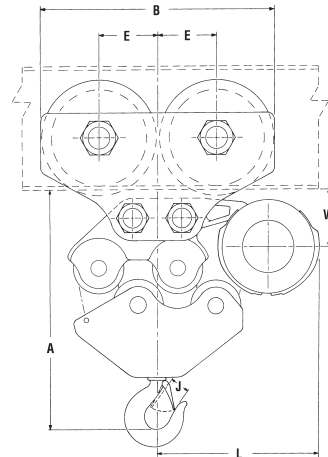
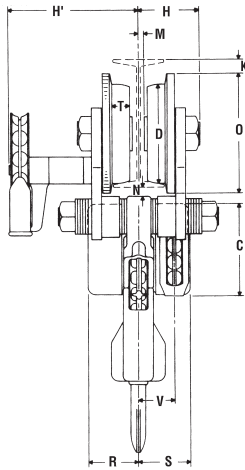

**10 Ton, Plain or Geared**

CAP IN TONS	ALL DIMENSIONS SHOWN IN INCHES																				
	A	B	C	D	E	F	H	H'	I	J	K	L	M	N	O	P	R	S	T	V	W
8	24 <sup>5</sup> / <sub>8</sub>	21	9 <sup>3</sup> / <sub>4</sub>	8 <sup>1</sup> / <sub>4</sub>	5 <sup>1</sup> / <sub>4</sub>	-	6 <sup>1</sup> / <sub>4</sub>	13 <sup>1</sup> / <sub>2</sub>	-	2 <sup>1</sup> / <sub>16</sub>	<sup>3</sup> / <sub>8</sub>	14	<sup>1</sup> / <sub>2</sub>	1 <sup>3</sup> / <sub>4</sub>	10	-	5	5	1 <sup>11</sup> / <sub>16</sub>	3 <sup>1</sup> / <sub>4</sub>	8 <sup>5</sup> / <sub>8</sub>
10	25	23 <sup>3</sup> / <sub>4</sub>	9 <sup>3</sup> / <sub>4</sub>	9 <sup>3</sup> / <sub>4</sub>	6	-	6 <sup>1</sup> / <sub>4</sub>	12 <sup>3</sup> / <sub>4</sub>	-	2 <sup>1</sup> / <sub>4</sub>	<sup>7</sup> / <sub>8</sub>	16 <sup>1</sup> / <sub>2</sub>	<sup>1</sup> / <sub>2</sub>	<sup>3</sup> / <sub>4</sub>	11 <sup>11</sup> / <sub>16</sub>	-	5	5	1 <sup>3</sup> / <sub>4</sub>	3 <sup>1</sup> / <sub>4</sub>	6 <sup>1</sup> / <sub>2</sub>

# CHESTER HOIST

Zephyr

**MECHANICALLY ENCLOSED** Heavy steel housings keep out most foreign material, protecting precision-machined working parts.

**GREASE TIGHT-ENCLOSED** Complete enclosure, sealed construction keeps lubrication in, making the Chester Zephyr a lifetime-lubricated hoist under normal conditions. No protruding parts, resists snagging.

**SHOCK RESISTANT** Heavy gauge steel in the stamped covers, two rolled steel sections in the frame, and use of strong alloy steels in suspension members make the Zephyr a sturdy hoist.

**EASIER HANDLING** Lightweight, compact construction makes the Zephyr portable to practically any location in the plant, able to operate in tight corners.

**EASY DISMANTLING** Making periodic inspections, or replacing chains or parts, requires only a small wrench and screwdriver.

**GEAR TRAIN** Center planetary system using modified involute stub tooth form. Gear teeth are cut from solid alloy steel blanks and heat treated.

**INTERNAL GEAR** Nickel-chrome-molybdenum alloy steel, machine-cut teeth. Internal gear is heat treated and welded to frame.

**GEARS AND PINIONS** Nickel-chrome-molybdenum alloy steel, machine-cut teeth, heat treated, and mounted on heavy duty roller bearings.

**GEAR AND PINION SHAFTS** Rigidly mounted alloy steel, surface-hardened and ground.

**PINION CAGE** Spline fitted to the steel load wheel shaft.

**DRIVING SPINDLE** Nickel-chrome-molybdenum alloy steel, with machine-cut teeth. Operates on heavy duty bearings.

**LOAD WHEEL** Heat treated cast steel with spline fit to load shaft. Chain pockets are accurately formed, and load wheel can be reversed when new chain is installed to effect double life.

**CHESTER ZEPHYR** hoists are designed, built and tested to rigid specifications of quality and performance, to exceed standards common to the hoist industry.

The Chester Zephyr is a thoroughly engineered hoist from every standpoint. It has been made light in weight, compact and sturdy enough to serve as a rigger's hoist. Its simplicity of design makes it easy to service and maintain, insures long trouble-free periods of service. It is a stronger, more durable hoist because its fully enclosed construction makes it more shock resistant and impervious to practically any normal operating condition. Outdoors or in, the Zephyr hoist can withstand weather extremes.

Compactly constructed, the Zephyr is adaptable to many close-quarter operations. The Zephyr requires only a minimum of headroom. Combined with its lightweight feature and with its adaptability to a wide variety of industrial operating conditions, the Chester Zephyr stands out as a versatile piece of material handling equipment.

**CHAIN STRIPPER** Ductile Iron.

**LOAD BRAKE** Positive action. Weston type with uniform composition lining and quiet-action forged alloy pawl.

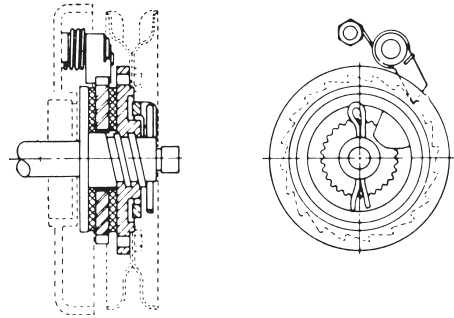

**LOAD CHAIN GUIDE** Completely shrouds load sheave, guides chain into load wheel and efficiently shields these parts from entry of foreign objects.

**LOAD CHAIN** Steel, with accurately formed links to fit pockets of load wheel. Heat treated for high tensile strength and hardness.

**HAND CHAIN GUIDE** Designed to eliminate fouling, and to permit angular pull on the hand chain.

**TOP HOOK ASSEMBLY** Permits hoist to rock and swivel under load. Alloy crosshead rocks in rolled steel straps welded to frame. Alloy hook is heat treated. Drop-forged alloy steel hook will open before fracturing.

**BOTTOM HOOK ASSEMBLY** Consists of forged alloy steel hook operating on thrust bearing with full swiveling action.

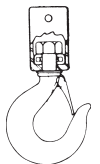

It will do lifting and lowering efficiently and quickly. It will provide superior service through many years of operation and can be an important factor in lessening work fatigue, raising morale, reducing handling costs and time, and stepping up plant efficiency.

**ALL SUSPENSION MEMBERS ARE STEEL**

**\* 1 WARNING**

**Overloading and improper use can result in injury.**

**To avoid injury:**

- Do not exceed working load limit, load rating or capacity.
- Do not use to lift people or loads over people.
- Use only alloy chain and attachments for overhead lifting.
- Read and follow all instructions.
- This equipment for manual operation only.