OWNER'S MANUAL

ELECTRIC WIRE ROPE HOIST and TROLLEY RH SERIES

2 Ton through 20 Ton Capacity

Product Code and Serial Number

⚠ WARNING

This equipment should not be installed, operated or maintained by any person who has not read and understood all the contents of this manual. Failure to read and comply with the contents of this manual can result in serious bodily injury or death, and/or property damage.

HARRINGTON
HOISTS AND CRANES

Table of Contents

Section	Page Number
1.0 Important Information and Warnings.....	4
1.1 Terms and Summary	
1.2 Warning Tags and Labels	
2.0 Technical Information	8
2.1 Specifications and Dimensions	
2.2 Miscellaneous Information	
3.0 Pre-operational Procedures.....	21
3.1 General Information	
3.2 Handling	
3.3 Mounting Location	
3.4 Assembly, Adjustments and Mounting	
3.5 Electrical Connections	
3.6 Reeving and Adjustments	
3.7 Pre-operational Checks and Trial Operation	
4.0 Operation.....	40
4.1 Introduction	
4.2 Shall's and Shall Not's for Operation	
4.3 Hoist and Trolley Controls	
5.0 Inspection.....	43
5.1 General	
5.2 Inspection Classification	
5.3 Frequent Inspection	
5.4 Periodic Inspection	
5.5 Occasionally Used Hoists and Trolleys	
5.6 Inspection Records	
5.7 Inspection Methods and Criteria	

Section	Page Number
6.0 Maintenance & Handling.....	53
6.1 Lubrication	
6.2 Hoist Motor Brake	
6.3 Trolley Motor Brake	
Wire Rope	
6.4 Storage	
6.5 Outdoor Installation	
7.0 Troubleshooting.....	64
8.0 Warranty.....	67

1.0 Important Information and Warnings

1.1 Terms and Summary

This manual provides important information for personnel involved with the installation, operation and maintenance of this product. Although you may be familiar with this or similar equipment, it is strongly recommended that you read this manual before installing, operating or maintaining the product.

Danger, Warning, Caution and Notice - Throughout this manual there are steps and procedures that can present hazardous situations. The following signal words are used to identify the degree or level of hazard seriousness.

⚠ DANGER Danger indicates an imminently hazardous situation which, if not avoided, **will** result in **death or serious injury**, and property damage.

⚠ WARNING Warning indicates an imminently hazardous situation which, if not avoided, **could** result in **death or serious injury**, and property damage.

⚠ CAUTION Caution indicates a potentially hazardous situation which, if not avoided, **may** result **minor or moderate injury** or property damage.

NOTICE Notice is used to notify people of installation, operation, or maintenance information which is important but not directly hazard-related.

important but not directly hazard-related.

⚠ CAUTION

These general instructions deal with the normal installation, operation, and maintenance situations encountered with the equipment described herein. The instructions should not be interpreted to anticipate every possible contingency or to anticipate the final system, crane, or configuration that uses this equipment. For systems using the equipment covered by this manual, the supplier and owner of the system are responsible for the system's compliance with all applicable industry standards, and with all applicable federal, state and local regulations/codes.

This manual includes instructions and parts information for a variety of trolley and hoist types. Therefore, all instructions and parts information may not apply to any one type or size of specific trolley or hoist. Disregard those portions of the instructions that do not apply.

Record your hoist and trolley's Product Code and Serial Number on the front cover of this manual for identification and future reference to avoid referring to the wrong manual for information or instructions on installation, operation, inspection, maintenance, or parts.

Use only Harrington authorized replacement parts in the service and maintenance of this trolley.

WARNING

Equipment described herein is not designed for and **MUST NOT** be used for lifting, supporting, or transporting people, or for lifting or supporting loads over people.

Equipment described herein should not be used in conjunction with other equipment unless necessary and/or required safety devices applicable to the system, crane, or application are installed by the system designer, system manufacturer, crane manufacturer, installer, or user.

Modifications to upgrade, rerate, or otherwise alter this equipment shall be authorized only by the original equipment manufacturer.

Equipment described herein may be used in the design and manufacture of cranes or monorails. Additional equipment or devices may be required for the crane and monorail to comply with applicable crane design and safety standards. The crane designer, crane manufacturer, or user is responsible to furnish these additional items for compliance. Refer to ANSI/ASME B30.17, "Safety Standard for Top-Running Single Girder Cranes"; ANSI/ASME B30.2 "Safety Standard for Top-Running Double-Girder Cranes"; and ANSI/ASME B30.11 "Safety Standard for Underhung Cranes and Monorails".

Hoists, trolleys and cranes, used to handle hot molten material may require additional equipment or devices. Refer to ANSI Z241.2, "Safety Requirements for Melting and Pouring of Metals in the Metalcasting Industry".

Electrical equipment described herein is designed and built in compliance with Harrington's interpretation of ANSI/NFPA 70, "National Electrical Code". The system designer, system manufacturer, crane designer, crane manufacturer, installer, or user is responsible to assure that the installation and associated wiring of these electrical components is in compliance with ANSI/NFPA 70, and all applicable Federal, State and Local Codes.

Failure to read and comply with any one of the limitations noted herein can result in serious bodily injury or death, and/or property damage.

DANGER

HAZARDOUS VOLTAGES ARE PRESENT IN THE CONTROL BOX, OTHER ELECTRICAL COMPONENTS, AND CONNECTIONS BETWEEN THESE COMPONENTS.

Before performing ANY mechanical or electrical maintenance on the equipment, de-energize (disconnect) the main switch supplying power to the equipment; and lock and tag the main switch in the de-energized position. Refer to ANSI Z244.1, "Personnel Protection – Lockout/Tagout of Energy Sources".

Only trained and competent personnel should inspect and repair this equipment.

NOTICE

It is the responsibility of the owner/user to install, inspect, test, maintain, and operate a trolley or hoist in accordance with ANSI/ASME B30.16, "Safety Standard for Overhead Hoists", OSHA Regulations and ANSI/NFPA 70, "National Electric Code". If the trolley is installed as part of a total lifting system, such as an overhead crane or monorail, it is also the responsibility of the owner/user to comply with the applicable ANSI/ASME B30 volume that addresses that type of equipment.

It is the responsibility of the owner/user to have all personnel that will install, inspect, test, maintain, and operate a hoist read the contents of this manual and applicable portions of ANSI/ASME B30.16, "Safety Standard for Overhead Hoists", OSHA Regulations and ANSI/NFPA 70, "National Electric Code". If the trolley is installed as part of a total lifting system, such as an overhead crane, the applicable ANSI/ASME B30 volume that addresses that type of equipment must also be read by all personnel.

If the trolley owner/user requires additional information, or if any information in the manual is not clear, contact Harrington or the distributor of the trolley. Do not install, inspect, test, maintain, or operate this trolley unless this information is fully understood.

A regular schedule of inspection of the trolley in accordance with the requirements of ANSI/ASME B30.16 should be established and records maintained.

1.2 Warning Tag and Labels

The warning tag illustrated below in Figure 1-1 is supplied with each hoist and trolley shipped from the factory. If the tag is not attached to the pendant cord for your hoist/trolley, order a tag from your dealer and install it. Read and obey all warnings attached to this Hoist/Trolley. Tag is not shown actual size.

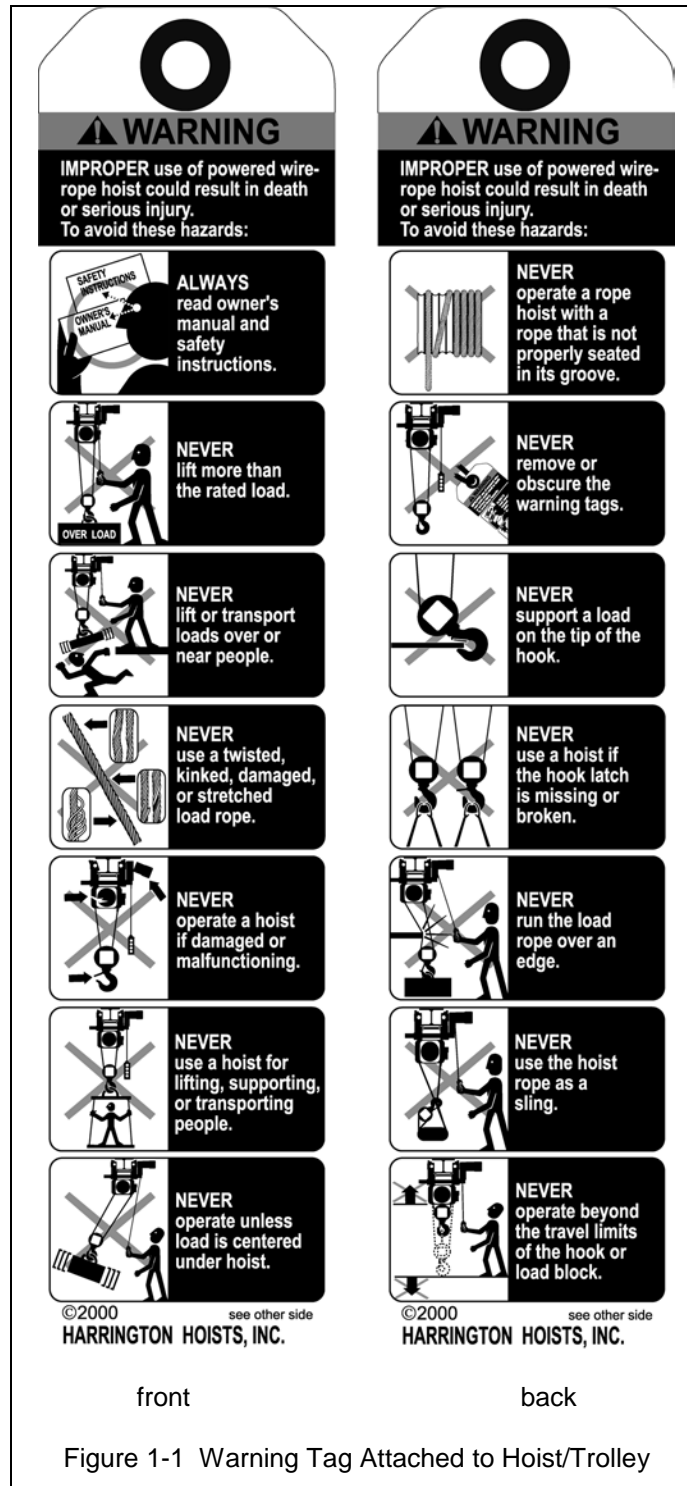
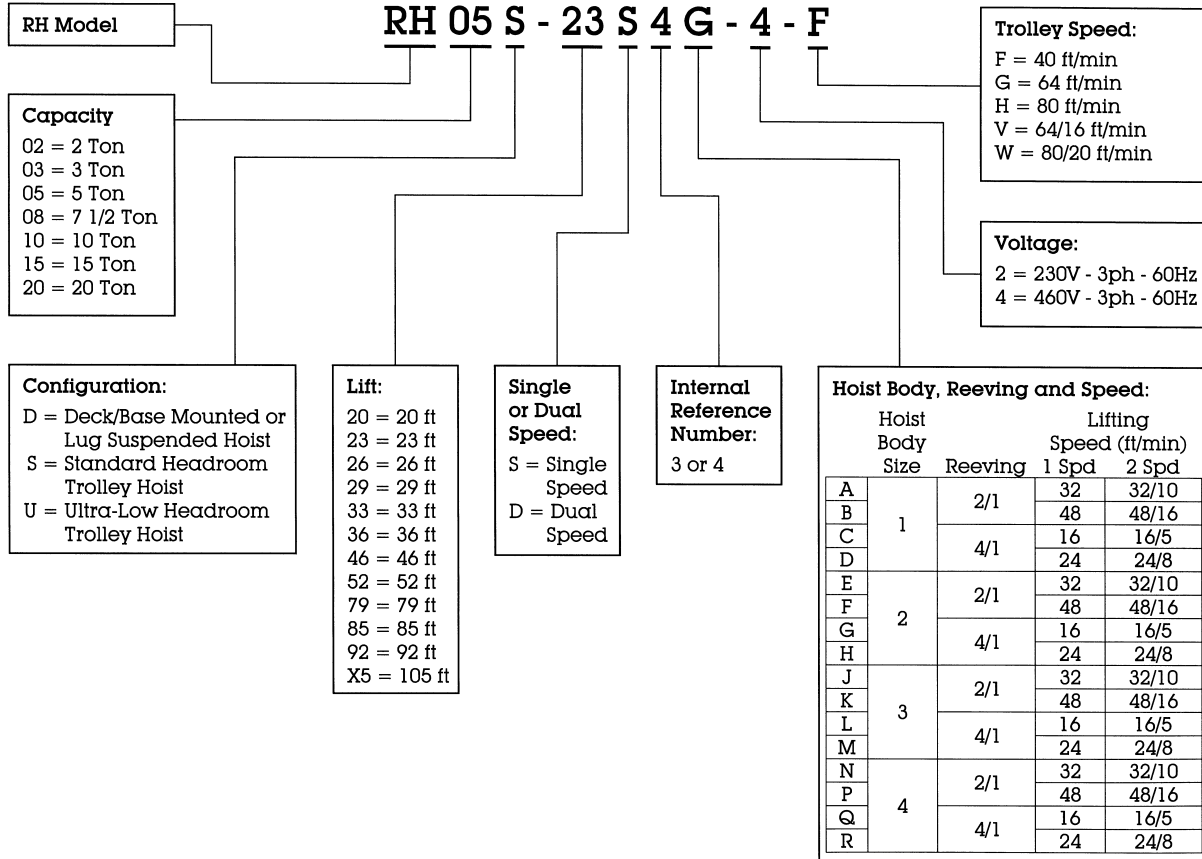

Figure 1-1 Warning Tag Attached to Hoist/Trolley

2.0 Technical Information

2.1 Specifications

2.1.1 Product Code:



2.1.2 Hoist and Trolley Size – The RH hoists and trolleys are available in 4 basic sizes. These sizes are referred to throughout this manual to identify what information applies to which hoist and trolley. The 10th digit in the product code designates the sizes as shown in Table 2-1 below.

10 TH Digit in Product Code	Hoist Size	Trolley Size
A, B, C or D	1	1
E or F	2	1
G or H	2	2
J or K	3	2
L or M	3	3
N or P	4	3
Q or R	4	4

*Noncatalog or special RH hoists and trolleys MAY NOT follow the sizes shown in Table 2-1.

2.1.3 Operating Conditions and Environment

Temperature Range: +14° to +104°F (-10° to +40°C)
 Humidity: 80% or less
 Electrical Enclosure Rating: IP55
 Brake Enclosure Rating: IP23
 Supply Voltage: 230V-3ph-60Hz or 460V-3ph-60Hz
 Control Voltage: 110V-1ph-60Hz

2.1.4 Deck/Base Mounted or Lug Suspended Hoist Specification and Dimensions

Table 2-2 Deck/Base Mounted or Lug Suspended Hoists – Specifications													
Capacity (Tons)	Product Code	Lift (ft)	Lifting Speed (ft/min)		Reeving (parts/reaving)	Rope** (mm-spec.)	Single Speed Lifting Motor 3 Phase 60Hz			Dual Speed Lifting Motor 3 Phase 60Hz			Net Weight (lbs)
			Single Speed	Dual Speed			Output (Hp)	Rated Current (amps)		Output (Hp)	Rated Current (amps)		
								@460V	@230V		@460V	@230V	
2	RH02D-20①4C-②	20	16	16/5	4/1	7-B	4.8	7.7	15.4	4.8/1.6	7.7/6.3	15.4/12.5	331
	RH02D-29①4C-②	29											375
	RH02D-20①4D-②	20	24	24/8									331
	RH02D-29①4D-②	29			375								
	RH02D-39①3A-②	39	32	32/10	2/1	7-A							311
	RH02D-79①3A-②	79			7-A*	353							
3	RH03D-20①4C-②	20	16	16/5	4/1	7-A	4.8	7.7	15.4	4.8/1.6	7.7/6.3	15.4/12.5	331
	RH03D-29①4C-②	29											375
	RH03D-23①4H-②	23	24	24/8									9-B
	RH03D-33①4H-②	33			518								
	RH03D-46①3E-②	46	32	32/10	2/1	9-A							430
	RH03D-85①3E-②	85			9-A*	474							
5	RH05D-23①4G-②	23	16	16/5	4/1	9-A	8.0	11.5	23.0	8.0/2.7	11.5/9.6	23.0/19.0	452
	RH05D-33①4G-②	33											518
	RH05D-23①4M-②	23	24	24/8									13-B
	RH05D-33①4M-②	33			1378								
	RH05D-46①4J-②	46	32	32/10	2/1	13-A							1080
	RH05D-92①4J-②	92			13-A*	1246							
	RH05D-52①4P-②	52	48	48/16	16-B	1962							
	RH05D-X5①4P-②	105			16-B*	2227							
7 1/2	RH08D-23①4L-②	23	16	16/5	4/1	13-M	16.1	21.0	42.0	16.1/5.4	23.0/17.3	46.0/34.5	1190
	RH08D-33①4L-②	33											1378
	RH08D-23①3M-②	23	24	24/8									13-B
	RH08D-33①3M-②	33			1378								
	RH08D-52①4N-②	52	32	32/10	2/1	16-A							1962
	RH08D-X5①4N-②	105			16-A*	2227							
10	RH10D-23①4L-②	23	16	16/5	4/1	13-A	16.1	21.0	42.0	16.1/5.4	23.0/17.3	46.0/34.5	1190
	RH10D-33①4L-②	33											1378
	RH10D-26①4R-②	26	24	24/8									16-B
	RH10D-36①4R-②	36			2513								
	RH10D-52①3N-②	52	32	32/10	2/1	16-A							1962
	RH10D-X5①3N-②	105			16-A*	2227							
15	RH15D-26①4Q-②	26	16	16/5	4/1	16-A	25.7	33.0	69.0	19.2/6.3	36.5/29.0	79.0/60.0	2205
	RH15D-36①4Q-②	36											2513
20	RH20D-26①3Q-②	26	16	16/5	4/1	16-A	25.7	33.0	69.0	19.2/6.3	36.5/29.0	79.0/60.0	2205
	RH20D-36①3Q-②	36											2513

① S = Single Speed Hoist
 D = Dual Speed Hoist
 ② 2 = 230V – 3ph – 60Hz
 4 = 460V – 3ph – 60Hz

*2/1 long lift hoists are fitted with anti-revolving rope.
 **Rope strengths are specified as: B = Base
 M = Medium
 A = High

Table 2-3 Deck/Base Mounted or Lug Suspended Hoists – Dimensions*

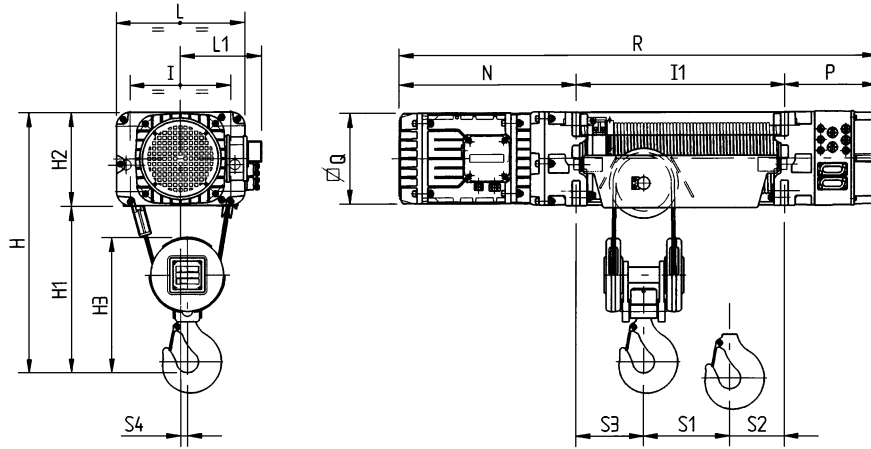

Capacity (Tons)	Product Code	H (in)	H1 (in)	H2 (in)	H3 (in)	I (in)	I1 (in)	L (in)	L1 (in)	N (in)	P (in)	ØQ (in)	R (in)	S1 (in)	S2 (in)	S3 (in)	S4 (in)	
2	RH02D-20①4C-②	25.6	16.5	9.1	13.6	9.8	20.3	12.6	8.3	18.3	10.0	8.9	48.6	3.9	10.4	5.9	0.6	
	RH02D-29①4C-②						35.0						63.4	6.3	22.2	6.5		
	RH02D-20①4D-②						20.3						48.6	3.9	10.4	5.9		
	RH02D-29①4D-②						35.0						63.4	6.3	22.2	6.5		
	RH02D-39①3A-②	27.2	18.1		15.4		20.3						48.6	7.3	9.3	3.7	1.1	
	RH02D-79①3A-②						35.0						63.4	10.8	20.5			
3	RH03D-20①4C-②	25.6	16.5	9.1	13.6	9.8	20.3	12.6	8.3	18.3	10.0	8.9	48.6	3.9	10.4	5.9	0.6	
	RH03D-29①4C-②						35.0						63.4	6.3	22.8			
	RH03D-23①4H-②	29.5	18.9	10.6	15.4	11.4	23.6	14.6	9.3	20.1	10.6	10.2	54.3	5.3	11.2	7.1	0.7	
	RH03D-33①4H-②						39.4						70.1	8.3	24			
	RH03D-46①3E-②	32.3	21.7	10.6	17.5		23.6							54.3	8.7	11.0	3.9	1.2
	RH03D-85①3E-②						39.4							70.1	12.2	23.2		
5	RH05D-23①4G-②	29.5	18.9	10.6	15.4	11.4	23.6	14.6	9.3	20.1	10.6	10.2	54.3	5.3	11.2	7.1	0.7	
	RH05D-33①4G-②						39.4						70.1	8.3	24.0			
	RH05D-23①4M-②	40.2	25.2	15.0	21.3	14.6	29.1	18.9	11.4	27.0	8.1	11.8	64.2	6.3	13.4	9.4	0.9	
	RH05D-33①4M-②						49.6						84.6	9.4	30.7			
	RH05D-46①4J-②	42.9	28.0		23.4		29.1							64.2	10.4	13.6	5.1	1.6
	RH05D-92①4J-②						49.6							84.6	14.8	29.7		
	RH05D-52①4P-②	55.1	36.2	18.5	29.5	18.1	33.9	23.6	14.2	32.9	8.7	13.4	76.2	11.4	15.7	6.7	1.8	
	RH05D-X5①4P-②						55.9						98.2	15.7	33.5			
7 1/2	RH08D-23①4L-②	40.2	25.2	15.0	21.3	14.6	29.1	18.9	11.4	27.0	8.1	11.8	64.2	6.3	13.4	9.4	0.9	
	RH08D-33①4L-②						49.6						84.6	9.4	30.7			
	RH08D-23①3M-②						29.1						64.2	6.3	13.4			
	RH08D-33①3M-②						49.6						84.6	9.4	30.7			
	RH08D-52①4N-②	55.1	36.2	18.5	29.5	18.1	33.9	23.6	14.2	32.9	8.7	13.4	76.2	11.4	15.7	6.7	1.8	
	RH08D-X5①4N-②						55.9						98.2	15.7	33.5			
10	RH10D-23①4L-②	40.2	25.2	15.0	21.3	14.6	29.1	18.9	11.4	27	8.1	11.8	64.2	6.3	13.4	9.4	0.9	
	RH10D-33①4L-②						49.6						84.6	9.4	30.7			
	RH10D-26①4R-②	52.0	33.5	18.5	27.6	18.1	33.9	23.6	14.2	32.9	8.7	13.4	76.2	7.1	13	13.8	1.0	
	RH10D-36①4R-②						55.9						98.2	8.7	33.5			
	RH10D-52①3N-②	55.1	36.2		29.5		33.9							76.2	11.4	15.7	6.7	1.8
	RH10D-X5①3N-②						55.9							98.2	15.7	33.5		
15	RH15D-26①4Q-②	52.0	33.5	18.5	27.6	18.1	33.9	23.6	14.2	32.9	8.7	13.4	76.2	7.1	13	13.8	1.0	
	RH15D-36①4Q-②						55.9						98.2	8.7	33.5			
20	RH20D-26①3Q-②	52.0	33.5	18.5	27.6	18.1	33.9	23.6	14.2	32.9	8.7	13.4	76.2	7.1	13	13.8	1.0	
	RH20D-36①3Q-②						55.9						98.2	8.7	33.5			

*See Table 2-11 for Deck/Base Mounted or Lug Suspended eye bolt and attachment point dimensions.

2.1.5 Standard Headroom Trolley Hoists Specification and Dimensions

Table 2-4 Standard Headroom Trolley Hoists – Hoist Specifications

Capacity (Tons)	Product Code	Lift (ft)	Lifting Speed (ft/min)		Reeving (parts/reeving)	Rope** (mm-spec.)	Single Speed Lifting Motor 3 Phase 60Hz			Dual Speed Lifting Motor 3 Phase 60Hz			Net Weight (lbs)													
			Single Speed	Dual Speed			Output (Hp)	Rated Current (amps)		Output (Hp)	Rated Current (amps)															
								@460V	@230V		@460V	@230V														
2	RH02S-20①4C-②-③	20	16	16/5	4/1	7-B	4.8	7.7	15.4	4.8/1.6	7.7/6.3	15.4/12.5	529													
	RH02S-29①4C-②-③	29											573													
	RH02S-20①4D-②-③	20	24	24/8									529													
	RH02S-29①4D-②-③	29											573													
	RH02S-39①3A-②-③	39	32	32/10									2/1	509												
	RH02S-79①3A-②-③	79												551												
3	RH03S-20①4C-②-③	20	16	16/5	4/1	7-A	4.8	7.7	15.4	4.8/1.6	7.7/6.3	15.4/12.5	529													
	RH03S-29①4C-②-③	29											573													
	RH03S-23①4H-②-③	23	24	24/8									9-B	8.0	11.5	23.0	8.0/2.7	11.5/9.6	23.0/19.0	728						
	RH03S-33①4H-②-③	33																		794						
	RH03S-46①3E-②-③	46	32	32/10									2/1							617						
	RH03S-85①3E-②-③	85																		672						
5	RH05S-23①4G-②-③	23	16	16/5	4/1	9-A	8.0	11.5	23.0	8.0/2.7	11.5/9.6	23.0/19.0	728													
	RH05S-33①4G-②-③	33											794													
	RH05S-23①4M-②-③	23	24	24/8									13-B	16.1	21.0	42.0	16.1/5.4	23.0/17.3	46.0/34.5	1918						
	RH05S-33①4M-②-③	33																		2083						
	RH05S-46①4J-②-③	46	32	32/10									2/1							1378						
	RH05S-92①4J-②-③	92																		1543						
	RH05S-52①4P-②-③	52	48	48/16									16-B							25.7	33.0	69.0	19.2/6.3	36.5/29.0	79.0/60.0	2690
	RH05S-X5①4P-②-③	105																								2954
7 1/2	RH08S-23①4L-②-③	23	16	16/5	4/1	13-M	16.1	21.0	42.0	16.1/5.4	23.0/17.3	46.0/34.5	1918													
	RH08S-33①4L-②-③	33											2083													
	RH08S-23①3M-②-③	23	24	24/8									13-B	25.7	33.0	69.0	19.2/6.3	36.5/29.0	79.0/60.0							1918
	RH08S-33①3M-②-③	33																								2083
	RH08S-52①4N-②-③	52	32	32/10									2/1													2690
	RH08S-X5①4N-②-③	105																								2954
10	RH10S-23①4L-②-③	23	16	16/5	4/1	13-A	16.1	21.0	42.0	16.1/5.4	23.0/17.3	46.0/34.5	1918													
	RH10S-33①4L-②-③	33											2083													
	RH10S-26①4R-②-③	26	24	24/8									16-B	25.7	33.0	69.0	19.2/6.3	36.5/29.0	79.0/60.0	3351						
	RH10S-36①4R-②-③	36																		3660						
	RH10S-52①3N-②-③	52	32	32/10									2/1							2690						
	RH10S-X5①3N-②-③	105																		2954						
15	RH15S-26①4Q-②-③	26	16	16/5	4/1	16-A	25.7	33.0	69.0	19.2/6.3	36.5/29.0	79.0/60.0	3351													
	RH15S-36①4Q-②-③	36											3660													
20	RH20S-26①3Q-②-③	26	16	16/5	4/1	16-A	25.7	33.0	69.0	19.2/6.3	36.5/29.0	79.0/60.0	3351													
	RH20S-36①3Q-②-③	36											3660													

- ① S = Single Speed Hoist
D = Dual Speed Hoist
- ② 2 = 230V – 3ph – 60Hz
4 = 460V – 3ph – 60Hz
- ③ Traversing Speed:
F = 40 ft/min
G = 64 ft/min
H = 80 ft/min
V = 64/16 ft/min
W = 80/20 ft/min

*2/1 long lift hoists are fitted with anti-revolving rope.
**Rope strengths are specified as: B = Base
M = Medium
A = High

Table 2-5 Standard Headroom Trolley Hoists – Trolley Specifications

Capacity (Tons)	Product Code	Standard Flange Range B* (in)	Traversing Motors								
			Single Speed 40 ft/min			Single Speed 64 and 80 ft/min			Dual Speed 64/16 and 80/20 ft/min		
			Output (Hp)	Rated Current (amps)		Output (Hp)	Rated Current (amps)		Output (Hp)	Rated Current (amps)	
				@460V	@230V		@460V	@230V		@460V	@230V
2	RH02S-20①4C-②-③	3.54 to 11.02	0.32	1.1	2.2	0.6	1.1	3.0	0.6/0.13	1.3/1.1	2.5/2.2
	RH02S-29①4C-②-③										
	RH02S-20①4D-②-③										
	RH02S-29①4D-②-③										
	RH02S-39①3A-②-③										
RH02S-79①3A-②-③											
3	RH03S-20①4C-②-③	3.54 to 11.02	0.32	1.1	2.2	0.6	1.1	3.0	0.6/0.13	1.3/1.1	2.5/2.2
	RH03S-29①4C-②-③										
	RH03S-23①4H-②-③	4.69 to 11.02									
	RH03S-33①4H-②-③										
	RH03S-46①3E-②-③	3.54 to 11.02									
RH03S-85①3E-②-③											
5	RH05S-23①4G-②-③	4.69 to 11.02	0.32	1.1	2.2	0.6	1.1	3.0	0.6/0.13	1.3/1.1	2.5/2.2
	RH05S-33①4G-②-③										
	RH05S-23①4M-②-③	5.31 to 11.02	0.5			0.6	1.5	4.4	0.9/0.2	2.1/1.1	4.2/2.2
	RH05S-33①4M-②-③										
	RH05S-46①4J-②-③	4.69 to 11.02	0.32			0.6	1.1	3.0	0.6/0.13	1.3/1.1	2.5/2.2
	RH05S-92①4J-②-③										
	RH05S-52①4P-②-③	5.31 to 11.02	0.5			0.9	1.5	4.4	0.9/0.2	2.1/1.1	4.2/2.2
RH05S-X5①4P-②-③											
7 1/2	RH08S-23①4L-②-③	5.31 to 11.02	0.5	1.1	2.2	0.9	1.5	4.4	0.9/0.2	2.1/1.1	4.2/2.2
	RH08S-33①4L-②-③										
	RH08S-23①3M-②-③										
	RH08S-33①3M-②-③										
	RH08S-52①4N-②-③										
	RH08S-X5①4N-②-③										
10	RH10S-23①4L-②-③	5.31 to 11.02	0.5	1.1	2.2	0.9	1.5	4.4	0.9/0.2	2.1/1.1	4.2/2.2
	RH10S-33①4L-②-③										
	RH10S-26①4R-②-③	6.69 to 11.02									
	RH10S-36①4R-②-③										
	RH10S-52①3N-②-③	5.31 to 11.02									
RH10S-X5①3N-②-③											
15**	RH15S-26①4Q-②-③	6.69 to 11.02	0.5 x 2	1.1 x 2	2.2 x 2	0.9 x 2	1.5 x 2	4.4 x 2	0.9/0.2 x 2	2.1/1.1 x 2	4.2/2.2 x 2
	RH15S-36①4Q-②-③										
20**	RH20S-26①3Q-②-③	6.69 to 11.02	0.5 x 2	1.1 x 2	2.2 x 2	0.9 x 2	1.5 x 2	4.4 x 2	0.9/0.2 x 2	2.1/1.1 x 2	4.2/2.2 x 2
	RH20S-36①3Q-②-③										

*Optional wider flange ranges available. Wider flange range is the standard lower value to 15.75 inch.

Example: Wider flange range for 2 Ton trolley hoists is 3.54 to 15.75 inches.

**15 and 20 Ton models are equipped with 2 trolley motors.

Table 2-6 Standard Headroom Trolley Hoists – Dimensions

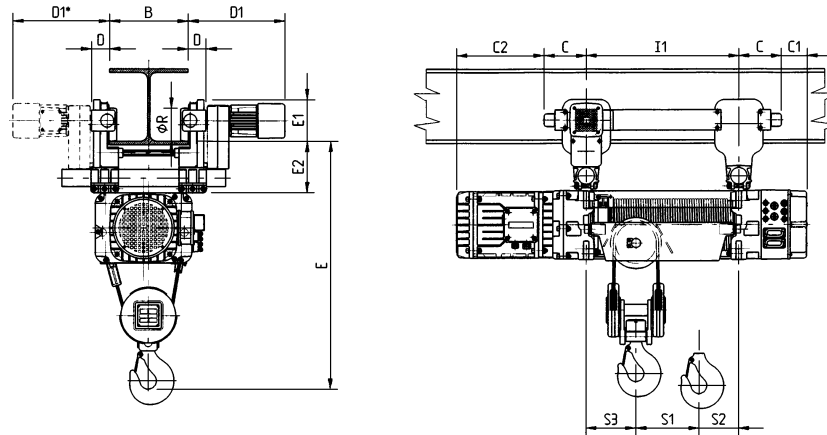

Note: ■ Standard headroom trolleys are suitable for use on S or W shaped beams.
 ■ Refer to Table 2-5 for flange range dimension B.

Capacity (Tons)	Product Code	C (in)	C1 (in)	C2 (in)	D (in)	D1 (in)	E (in)	E1 (in)	E2 (in)	I1 (in)	ØR (in)	S1 (in)	S2 (in)	S3 (in)
2	RH02S-20①4C-②-③	6.7	3.3	11.6	2.4	14.6	32.7	5.9	7.1	20.3	3.94	3.9	10.4	5.9
	RH02S-29①4C-②-③									35		6.3	22.8	
	RH02S-20①4D-②-③									20.3		3.9	10.4	
	RH02S-29①4D-②-③									35.0		6.3	22.8	
	RH02S-39①3A-②-③						34.3	20.3	7.3	9.3		3.7		
RH02S-79①3A-②-③	35	10.8	20.5											
3	RH03S-20①4C-②-③	6.7	3.3	11.6	2.4	14.6	32.7	5.9	7.1	20.3	3.94	3.9	10.4	5.9
	RH03S-29①4C-②-③									35.0		6.3	22.8	
	RH03S-23①4H-②-③	8.1	2.6	12	2.6	14.8	37.4	6.2	7.7	23.6	4.92	5.3	11.2	7.1
	RH03S-33①4H-②-③									39.4		8.3	24	
	RH03S-46①3E-②-③	6.7	3.9	13.4	2.4	14.6	39.4	5.9	7.1	23.6	3.94	8.7	11.0	3.9
RH03S-85①3E-②-③	39.4									12.2		23.2		
5	RH05S-23①4G-②-③	8.1	2.6	12	2.6	14.8	37.4	6.2	7.7	23.6	4.92	5.3	11.2	7.1
	RH05S-33①4G-②-③									39.4		8.3	24	
	RH05S-23①4M-②-③	11.4	-3.3	15.6	3.5	15.7	50.8	9.8	10.4	29.1	7.87	6.3	13.4	9.4
	RH05S-33①4M-②-③									49.6		9.4	30.7	
	RH05S-46①4J-②-③	8.1	0	18.9	2.7	14.8	50.8	6.2	7.7	29.1	4.92	10.4	13.6	5.1
	RH05S-92①4J-②-③									49.6		14.8	29.7	
	RH05S-52①4P-②-③	11.4	-2.8	21.5	3.5	15.7	65.7	9.8	10.4	33.9	7.87	11.4	15.7	6.7
RH05S-X5①4P-②-③	55.9									15.7		33.5		
7 1/2	RH08S-23①4L-②-③	11.4	-3.3	15.6	3.5	15.7	50.8	9.8	10.4	29.1	7.87	6.3	13.4	9.4
	RH08S-33①4L-②-③									49.6		9.4	30.7	
	RH08S-23①3M-②-③									29.1		6.3	13.4	
	RH08S-33①3M-②-③		49.6	9.4	30.7									
	RH08S-52①4N-②-③		-2.8	21.5	65.7	33.9	7.87	11.4	15.7	6.7				
	RH08S-X5①4N-②-③	55.9				15.7		33.5						
10	RH10S-23①4L-②-③	11.4	-3.3	15.6	3.5	15.7	50.8	9.8	10.4	29.1	7.87	6.3	13.4	9.4
	RH10S-33①4L-②-③									49.6		9.4	30.7	
	RH10S-26①4R-②-③	13.4	-4.7	19.5	3.9	16.1	63.8	12.2	12.0	33.9	9.84	7.1	13.0	13.8
	RH10S-36①4R-②-③									55.9		8.7	33.5	
	RH10S-52①3N-②-③	11.4	-2.8	21.5	3.5	15.7	65.7	9.8	10.4	33.9	7.87	11.4	15.7	6.7
RH10S-X5①3N-②-③	55.9									15.7		33.5		
15*	RH15S-26①4Q-②-③	13.4	-4.7	19.5	3.9	16.1	63.8	12.2	12.0	33.9	9.84	7.1	13.0	13.8
	RH15S-36①4Q-②-③									55.9		8.7	33.5	
20*	RH20S-26①3Q-②-③	13.4	-4.7	19.5	3.9	16.1	63.8	12.2	12.0	33.9	9.84	7.1	13.0	13.8
	RH20S-36①3Q-②-③									55.9		8.7	33.5	

*15 and 20 Ton models are equipped with 2 trolley motors.

2.1.6 Ultra-Low Headroom Trolley Hoists Specification and Dimensions

Table 2-7 Ultra-Low Headroom Trolley Hoists – Hoist Specifications

Capacity (Tons)	Product Code	Lift (ft)	Lifting Speed (ft/min)		Reeving (parts/reaving)	Rope** (mm-spec.)	Single Speed Lifting Motor 3 Phase 60Hz			Dual Speed Lifting Motor 3 Phase 60Hz			Net Weight (lbs)
			Single Speed	Dual Speed			Output (Hp)	Rated Current (amps)		Output (Hp)	Rated Current (amps)		
								@460V	@230V		@460V	@230V	
2	RH02U-20①4C-②-③	20	16	16/5	4/1	7-B	4.8	7.7	15.4	4.8/1.6	7.7/6.3	15.4/12.5	705
	RH02U-29①4C-②-③	29											750
	RH02U-20①4D-②-③	20	24	24/8									705
	RH02U-29①4D-②-③	29			750								
	RH02U-39①3A-②-③	39	32	32/10	2/1	7-A							686
	RH02U-79①3A-②-③	79				7-A*							728
3	RH03U-20①4C-②-③	20	16	16/5	4/1	7-A	4.8	7.7	15.4	4.8/1.6	7.7/6.3	15.4/12.5	705
	RH03U-29①4C-②-③	29											750
	RH03U-23①4H-②-③	23	24	24/8									9-B
	RH03U-33①4H-②-③	33			1102								
	RH03U-46①3E-②-③	46	32	32/10	2/1	9-A							893
	RH03U-85①3E-②-③	85				9-A*							948
5	RH05U-23①4G-②-③	23	16	16/5	4/1	9-A	8.0	11.5	23.0	8.0/2.7	11.5/9.6	23.0/19.0	1036
	RH05U-33①4G-②-③	33											1102
	RH05U-23①4M-②-③	23	24	24/8									13-B
	RH05U-33①4M-②-③	33			2811								
	RH05U-46①4J-②-③	46	32	32/10	2/1	13-A							2017
	RH05U-92①4J-②-③	92				13-A*							2183
	RH05U-52①4P-②-③	52	48	48/16	16-B	3869							
	RH05U-X5①4P-②-③	105			16-B*	4244							
7 1/2	RH08U-23①4L-②-③	23	16	16/5	4/1	13-M	16.1	21.0	42.0	16.1/5.4	23.0/17.3	46.0/34.5	2624
	RH08U-33①4L-②-③	33											2811
	RH08U-23①3M-②-③	23	24	24/8									13-B
	RH08U-33①3M-②-③	33			2811								
	RH08U-52①4N-②-③	52	32	32/10	2/1	16-A							3869
	RH08U-X5①4N-②-③	105				16-A*							4244
10	RH10U-23①4L-②-③	23	16	16/5	4/1	13-A	16.1	21.0	42.0	16.1/5.4	23.0/17.3	46.0/34.5	2624
	RH10U-33①4L-②-③	33											2811
	RH10U-26①4R-②-③	26	24	24/8									16-B
	RH10U-36①4R-②-③	36			5170								
	RH10U-52①3N-②-③	52	32	32/10	2/1	16-A							3869
	RH10U-X5①3N-②-③	105				16-A*							4244
15	RH15U-26①4Q-②-③	26	16	16/5	4/1	16-A	25.7	33.0	69.0	19.2/6.3	36.5/29.0	79.0/60.0	4707
	RH15U-36①4Q-②-③	36											5170
20	RH20U-26①3Q-②-③	26	16	16/5	4/1	16-A	25.7	33.0	69.0	19.2/6.3	36.5/29.0	79.0/60.0	4707
	RH20U-36①3Q-②-③	36											5170

- ① S = Single Speed Hoist
D = Dual Speed Hoist
- ② 2 = 230V – 3ph – 60Hz
4 = 460V – 3ph – 60Hz
- ③ Traversing Speed:
F = 40 ft/min
G = 64 ft/min
H = 80 ft/min
V = 64/16 ft/min
W = 80/20 ft/min

*2/1 long lift hoists are fitted with anti-revolving rope.
 **Rope strengths are specified as: B = Base
 M = Medium
 A = High

Table 2-8 Ultra-Low Headroom Trolley Hoists – Trolley Specifications

Capacity (Tons)	Product Code	Standard Flange Width B (in)	Traversing Motors								
			Single Speed 40 ft/min			Single Speed 64 and 80 ft/min			Dual Speed 64/16 and 80/20 ft/min		
			Output (Hp)	Rated Current (amps)		Output (Hp)	Rated Current (amps)		Output (Hp)	Rated Current (amps)	
				@460V	@230V		@460V	@230V		@460V	@230V
2	RH02U-20①4C-②-③	3.54 to 15.75	0.32	1.1	2.2	0.6	1.1	3.0	0.6/0.13	1.3/1.1	2.5/2.2
	RH02U-29①4C-②-③										
	RH02U-20①4D-②-③										
	RH02U-29①4D-②-③										
	RH02U-39①3A-②-③										
RH02U-79①3A-②-③											
3	RH03U-20①4C-②-③	3.54 to 15.75	0.32	1.1	2.2	0.6	1.1	3.0	0.6/0.13	1.3/1.1	2.5/2.2
	RH03U-29①4C-②-③										
	RH03U-23①4H-②-③	4.69 to 15.75									
	RH03U-33①4H-②-③										
	RH03U-46①3E-②-③	3.54 to 15.75									
RH03U-85①3E-②-③											
5	RH05U-23①4G-②-③	4.69 to 15.75	0.32	1.1	2.2	0.6	1.1	3.0	0.6/0.13	1.3/1.1	2.5/2.2
	RH05U-33①4G-②-③										
	RH05U-23①4M-②-③	5.31 to 15.75	0.5			0.9	1.5	4.4	0.9/0.2	2.1/1.1	4.2/2.2
	RH05U-33①4M-②-③										
	RH05U-46①4J-②-③	4.69 to 15.75	0.32			0.6	1.1	3.0	0.6/0.13	1.3/1.1	2.5/2.2
	RH05U-92①4J-②-③										
	RH05U-52①4P-②-③	5.31 to 15.75	0.5			0.9	1.5	4.4	0.9/0.2	2.1/1.1	4.2/2.2
RH05U-X5①4P-②-③											
7 1/2	RH08U-23①4L-②-③	5.31 to 15.75	0.5	1.1	2.2	0.9	1.5	4.4	0.9/0.2	2.1/1.1	4.2/2.2
	RH08U-33①4L-②-③										
	RH08U-23①3M-②-③										
	RH08U-33①3M-②-③										
	RH08U-52①4N-②-③										
RH08U-X5①4N-②-③											
10	RH10U-23①4L-②-③	5.31 to 15.75	0.5	1.1	2.2	0.9	1.5	4.4	0.9/0.2	2.1/1.1	4.2/2.2
	RH10U-33①4L-②-③										
	RH10U-26①4R-②-③	6.69 to 15.75									
	RH10U-36①4R-②-③										
	RH10U-52①3N-②-③	5.31 to 15.75									
RH10U-X5①3N-②-③											
15*	RH15U-26①4Q-②-③	6.69 to 15.75	0.5 x 2	1.1 x 2	2.2 x 2	0.9 x 2	1.5 x 2	4.4 x 2	0.9/0.2 x 2	2.1/1.1 x 2	4.2/2.2 x 2
	RH15U-36①4Q-②-③										
20*	RH20U-26①3Q-②-③	6.69 to 15.75	0.5 x 2	1.1 x 2	2.2 x 2	0.9 x 2	1.5 x 2	4.4 x 2	0.9/0.2 x 2	2.1/1.1 x 2	4.2/2.2 x 2
	RH20U-36①3Q-②-③										

*15 and 20 Ton models are equipped with 2 trolley motors.

Table 2-9 Ultra-Low Trolley Hoist – Headroom

Hoist Code	Flange Range (in)	Headroom, E** (in)	Headroom, E for 6 inch Flange (in)	Hoist Code	Flange Range (in)	Headroom, E** (in)	Headroom, E for 6 inch Flange (in)
A or B	3.54 to 15.75	17.3 + (1.13 x T)	24.1	J or K	4.69 to 8.66	26.8	26.8
					8.67 to 15.75	16.2 + (1.22 x T)	
C or D	3.54 to 6.79	18.9	18.9	L or M	4.69 to 10.51	24.0	24.0
	6.80 to 15.75	11.1 + (1.15 x T)			10.52 to 15.75	11.4 + (1.20 x T)	
E or F	3.54 to 15.75	17.6 + (1.13 x T)	24.8	N or P	5.31 to 10.16	32.7	32.7
					10.17 to 15.75	20.5 + (1.20 x T)	
G or H	4.69 to 6.49	18.9	18.9	Q or R	6.69 to 11.81	31.1	31.1***
	6.50 to 15.75	10.9 + (1.23 x T)			11.82 to 15.75	24.0 + (0.60 x T)	

**T in formulas is the exact beam flange width in inches.

***Headroom value for 7 inch flange.

Table 2-10 Ultra-Low Headroom Trolley Hoists – Dimensions

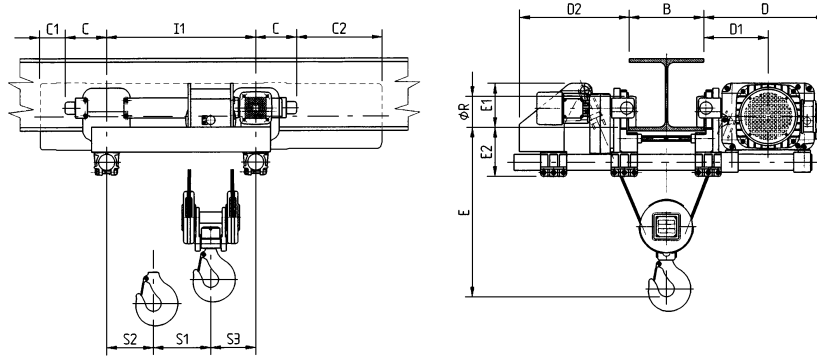

Note:
 ▪ Ultra-Low headroom trolleys are suitable for use on S or W shaped beams.
 ▪ Refer to Table 2-8 for flange range dimension B.
 ▪ Refer to Table 2-9 for headroom dimension E.

Capacity (Tons)	Product Code	C (in)	C1 (in)	C2 (in)	D (in)	D1 (in)	D2 (in)	E1 (in)	E2 (in)	I1 (in)	ØR (in)	S1 (in)	S2 (in)	S3 (in)
2	RH02U-20①4C-②-③	6.7	3.3	11.6	17.3	9.1	15.6	5.9	7.1	20.3	3.94	3.9	10.4	5.9
	RH02U-29①4C-②-③						14.4			35.0		6.3	22.8	
	RH02U-20①4D-②-③						15.6			20.3		3.9	10.4	
	RH02U-29①4D-②-③						14.4			35.0		6.3	22.8	
	RH02U-39①3A-②-③						15.6			20.3		7.3	9.3.0	
	RH02U-79①3A-②-③						14.4			35.0		10.8	20.5	
3	RH03U-20①4C-②-③	6.7	3.3	11.6	17.3	9.1	15.6	5.9	7.1	20.3	3.94	3.9	10.4	5.9
	RH03U-29①4C-②-③						14.4			35.0		6.3	22.8	
	RH03U-23①4H-②-③	8.1	2.6	12	19.5	10.2	17.3	7.1	7.7	23.6	4.92	5.3	11.2	7.1
	RH03U-33①4H-②-③						16.1			39.4		8.3	24	
	RH03U-46①3E-②-③	6.7	3.9	13.4	19.3	10.0	17.7	7.1	7.1	23.6	3.94	8.7	11.0	3.9
	RH03U-85①3E-②-③						16.5			39.4		12.2	23.2	
5	RH05U-23①4G-②-③	8.1	2.6	12.0	19.5	10.2	17.3	7.1	7.7	23.6	4.92	5.3	11.2	7.1
	RH05U-33①4G-②-③						16.1			39.4		8.3	24.0	
	RH05U-23①4M-②-③	11.4	-3.3	15.6	24.6	13.2	22.8	10.2	10.4	29.1	7.87	6.3	13.4	9.4
	RH05U-33①4M-②-③						21.7			49.6		9.4	30.7	
	RH05U-46①4J-②-③	8.1	0	18.9	23.8	12.4	24.0	11.8	7.7	29.1	4.92	10.4	13.6	5.1
	RH05U-92①4J-②-③						22.8			49.6		14.8	29.7	
	RH05U-52①4P-②-③	11.4	-2.8	21.5	29.7	15.6	27.0	13.6	10.4	33.9	7.87	11.4	15.7	6.7
	RH05U-X5①4P-②-③									55.9		15.7	33.5	
7 1/2	RH08U-23①4L-②-③	11.4	-3.3	15.6	24.6	13.2	22.8	10.2	10.4	29.1	7.87	6.3	13.4	9.4
	RH08U-33①4L-②-③						21.7			49.6		9.4	30.7	
	RH08U-23①3M-②-③						22.8			29.1		6.3	13.4	
	RH08U-33①3M-②-③		21.7	49.6	9.4	30.7								
	RH08U-52①4N-②-③		-2.8	21.5	29.7	15.6	27.0	13.6	10.4	33.9	7.87	11.4	15.7	6.7
	RH08U-X5①4N-②-③									55.9		15.7	33.5	
10	RH10U-23①4L-②-③	11.4	-3.3	15.6	24.6	13.2	22.8	10.2	10.4	29.1	7.87	6.3	13.4	9.4
	RH10U-33①4L-②-③						21.7			49.6		9.4	30.7	
	RH10U-26①4R-②-③	13.4	-4.7	19.5	30.1	15.9	25.6	13.6	12.0	33.9	9.84	7.1	13.0	13.8
	RH10U-36①4R-②-③						25.6			55.9		8.7	33.5	
	RH10U-52①3N-②-③	11.4	-2.8	21.5	29.7	15.6	27.0	13.6	10.4	33.9	7.87	11.4	15.7	6.7
	RH10U-X5①3N-②-③						27.0			55.9		15.7	33.5	
15*	RH15U-26①4Q-②-③	13.4	-4.7	19.5	30.1	15.9	25.6	13.6	12.0	33.9	9.84	7.1	13.0	13.8
	RH15U-36①4Q-②-③									55.9		8.7	33.5	
20*	RH20U-26①3Q-②-③	13.4	-4.7	19.5	30.1	15.9	25.6	13.6	12.0	33.9	9.84	7.1	13.0	13.8
	RH20U-36①3Q-②-③									55.9		8.7	33.5	

*15 and 20 Ton models are equipped with 2 trolley motors.

2.2 Miscellaneous Information

**Table 2-11 Eye Bolt and Attachment Point – Dimensions
For Deck/Base Mounted or Lug Suspended Hoists**

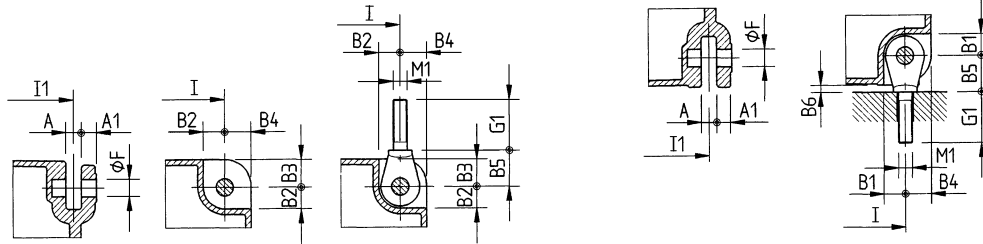

Note:

- Eyebolts are suitable for deck/base mounted or lug suspended applications.
- Eyebolt kits include four eyebolts and all necessary hardware.
- See Table 2-3 for dimensions I and I1.

Capacity (Tons)	Product Code	A (in)	A1 (in)	B1 (in)	B2 (in)	B3 (in)	B4 (in)	B5 (in)	ØF (mm)	G1 (in)	M1 (mm x pitch)
2	RH02S-20①4C-②	0.79	0.79	0.83	0.83	1.38	1.38	1.85	20	2.64	M16x2.0
	RH02S-29①4C-②										
	RH02S-20①4D-②										
	RH02S-29①4D-②										
	RH02D-39①3A-②										
RH02D-79①3A-②											
3	RH03D-20①4C-②	0.79	0.79	0.83	0.83	1.38	1.38	1.85	20	2.64	M16x2.0
	RH03D-29①4C-②										
	RH03D-23①4H-②										
	RH03D-33①4H-②										
	RH03D-46①3E-②										
RH03D-85①3E-②											
5	RH05D-23①4G-②	0.87	0.87	1.22	1.22	1.57	1.57	2.05	25	2.87	M20x2.5
	RH05D-33①4G-②										
	RH05D-23①4M-②	1.26	1.26	1.42	1.42	2.17	2.17	2.83	35	3.82	M24x3.0
	RH05D-33①4M-②										
	RH05D-46①4J-②										
	RH05D-92①4J-②										
RH05D-52①4P-②	1.65	1.65	1.50	1.81	2.76	2.76	3.35	45	4.41	M30x3.5	
RH05D-X5①4P-②											
7 1/2	RH08D-23①4L-②	1.26	1.26	1.42	1.42	2.17	2.17	2.83	35	3.82	M24x3.0
	RH08D-33①4L-②										
	RH08D-23①3M-②										
	RH08D-33①3M-②	1.65	1.65	1.50	1.81	2.76	2.76	3.35	45	4.41	M30x3.5
	RH08D-52①4N-②										
RH08D-X5①4N-②											
10	RH10D-23①4L-②	1.26	1.26	1.42	1.42	2.17	2.17	2.83	35	3.82	M24x3.0
	RH10D-33①4L-②										
	RH10D-26①4R-②	1.65	1.65	1.50	1.81	2.76	2.76	3.35	45	4.41	M30x3.5
	RH10D-36①4R-②										
	RH10D-52①3N-②										
RH10D-X5①3N-②											
15	RH15D-26①4Q-②	1.65	1.65	1.50	1.81	2.76	2.76	3.35	45	4.41	M30x3.5
	RH15D-36①4Q-②										
20	RH20D-26①3Q-②	1.65	1.65	1.50	1.81	2.76	2.76	3.35	45	4.41	M30x3.5
	RH20D-36①3Q-②										

Table 2-12 Bottom Hook – Dimensions

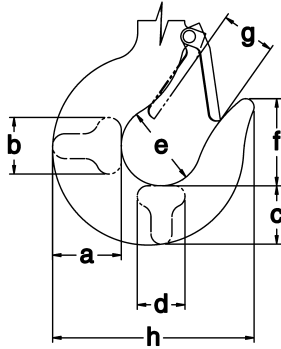

Capacity (Tons)	Product Code	a (in)	b (in)	c (in)	d (in)	e (in)	f (in)	g (in)	h (in)
2	RH02S-20①4C-②	2.2	1.8	1.9	1.5	2.2	2.5	1.5	5.7
	RH02S-29①4C-②								
	RH02S-20①4D-②								
	RH02S-29①4D-②								
	RH02D-39①3A-②	1.7	1.4	1.5	1.1	1.9	2.1	1.3	4.7
RH02D-79①3A-②									
3	RH03D-20①4C-②	2.2	1.8	1.9	1.5	2.2	2.5	1.5	5.7
	RH03D-29①4C-②								
	RH03D-23①4H-②	2.6	2.1	2.3	1.8	2.5	2.8	1.7	6.7
	RH03D-33①4H-②								
	RH03D-46①3E-②	2.2	1.8	1.9	1.5	2.2	2.5	1.5	5.7
RH03D-85①3E-②									
5	RH05D-23①4G-②	2.6	2.1	2.3	1.8	2.5	2.8	1.7	6.7
	RH05D-33①4G-②								
	RH05D-23①4M-②	3.5	2.8	3.0	2.4	3.1	3.5	2.0	8.9
	RH05D-33①4M-②								
	RH05D-46①4J-②	2.6	2.1	2.3	1.8	2.5	2.8	1.7	6.7
	RH05D-92①4J-②								
7 1/2	RH05D-52①4P-②	3.5	2.8	3.0	2.4	3.1	3.5	2.0	8.9
	RH05D-X5①4P-②								
	RH08D-23①4L-②	3.5	2.8	3.0	2.4	3.1	3.5	2.0	8.9
	RH08D-33①4L-②								
	RH08D-23①3M-②								
	RH08D-33①3M-②								
RH08D-52①4N-②									
RH08D-X5①4N-②									
10	RH10D-23①4L-②	3.5	2.8	3.0	2.4	3.1	3.5	2.0	8.9
	RH10D-33①4L-②								
	RH10D-26①4R-②	4.9	3.9	4.2	3.3	4.4	5.0	3.0	12.7
	RH10D-36①4R-②								
	RH10D-52①3N-②	3.5	2.8	3.0	2.4	3.1	3.5	2.0	8.9
RH10D-X5①3N-②									
15	RH15D-26①4Q-②	4.9	3.9	4.2	3.3	4.4	5.0	3.0	12.7
	RH15D-36①4Q-②								
20	RH20D-26①3Q-②	4.9	3.9	4.2	3.3	4.4	5.0	3.0	12.7
	RH20D-36①3Q-②								

Table 2-13 Reaction Forces at Rated Load

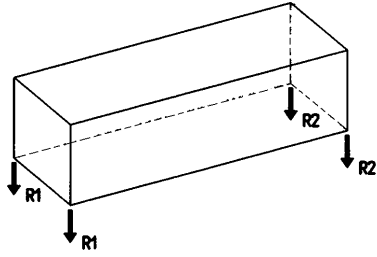

Deck/Base Mounted or Lug Suspended Hoists

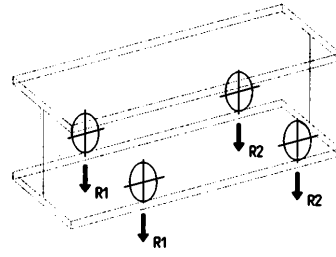

Standard or Ultra-Low Headroom Trolley Hoist

Capacity (Tons)	Deck/Base Mounted or Lug Suspended Attachment Point Reaction Forces			Standard Headroom Trolley Wheel Reaction Forces			Ultra-Low Headroom Trolley Wheel Reaction Forces		
	Product Code	R1 (lbs)	R2 (lbs)	Product Code	R1 (lbs)	R2 (lbs)	Product Code	R1 (lbs)	R2 (lbs)
2	RH02D-20①4C-②	1483	683	RH02S-20①4C-②-③	1600	665	RH02U-20①4C-②-③	1659	694
	RH02D-29①4C-②	1734	454	RH02S-29①4C-②-③	1826	461	RH02U-29①4C-②-③	1887	487
	RH02D-20①4D-②	1483	683	RH02S-20①4D-②-③	1600	665	RH02U-20①4D-②-③	1659	694
	RH02D-29①4D-②	1734	454	RH02S-29①4D-②-③	1826	461	RH02U-29①4D-②-③	1887	487
	RH02D-39①3A-②	1758	398	RH02S-39①3A-②-③	1854	401	RH02U-39①3A-②-③	1931	411
	RH02D-79①3A-②	1928	248	RH02S-79①3A-②-③	2025	250	RH02U-79①3A-②-③	2104	259
3	RH03D-20①4C-②	2183	983	RH03S-20①4C-②-③	2334	931	RH03U-20①4C-②-③	2400	953
	RH03D-29①4C-②	2554	634	RH03S-29①4C-②-③	2667	620	RH03U-29①4C-②-③	2737	637
	RH03D-23①4H-②	2213	1013	RH03S-23①4H-②-③	2297	1067	RH03U-23①4H-②-③	2405	1113
	RH03D-33①4H-②	2589	669	RH03S-33①4H-②-③	2650	747	RH03U-33①4H-②-③	2760	791
	RH03D-46①3E-②	5627	587	RH03S-46①3E-②-③	2652	656	RH03U-46①3E-②-③	2881	565
	RH03D-85①3E-②	2878	358	RH03S-85①3E-②-③	2896	440	RH03U-85①3E-②-③	3105	369
5	RH05D-23①4G-②	3613	1613	RH05S-23①4G-②-③	3707	1657	RH05U-23①4G-②-③	3836	1682
	RH05D-33①4G-②	4229	1029	RH05S-33①4G-②-③	4284	1112	RH05U-33①4G-②-③	4417	1135
	RH05D-23①4M-②	3798	1798	RH05S-23①4M-②-③	4004	1954	RH05U-23①4M-②-③	4233	2079
	RH05D-33①4M-②	4444	1244	RH05S-33①4M-②-③	4607	1435	RH05U-33①4M-②-③	4844	1562
	RH05D-46①4J-②	4470	1070	RH05S-46①4J-②-③	4671	1017	RH05U-46①4J-②-③	4929	1079
	RH05D-92①4J-②	4911	711	RH05S-92①4J-②-③	5102	670	RH05U-92①4J-②-③	5345	745
	RH05D-52①4P-②	4690	1290	RH05S-52①4P-②-③	4937	1407	RH05U-52①4P-②-③	5345	1589
	RH05D-X5①4P-②	5157	957	RH05S-X5①4P-②-③	5418	1058	RH05U-X5①4P-②-③	5861	1261
7 1/2	RH08D-23①4L-②	5548	2548	RH08S-23①4L-②-③	5767	2692	RH08U-23①4L-②-③	6022	2791
	RH08D-33①4L-②	6494	1694	RH08S-33①4L-②-③	6650	1892	RH08U-33①4L-②-③	6915	1992
	RH08D-23①3M-②	5548	2548	RH08S-23①3M-②-③	5767	2692	RH08U-23①3M-②-③	6022	2791
	RH08D-33①3M-②	6494	1694	RH08S-33①3M-②-③	6650	1892	RH08U-33①3M-②-③	6915	1992
	RH08D-52①4N-②	6790	1690	RH08S-52①4N-②-③	7070	1910	RH08U-52①4N-②-③	7534	1900
	RH08D-X5①4N-②	7457	1157	RH08S-X5①4N-②-③	7758	1218	RH08U-X5①4N-②-③	8261	1361
10	RH10D-23①4L-②	7298	3298	RH10S-23①4L-②-③	7529	3429	RH10U-23①4L-②-③	7810	3502
	RH10D-33①4L-②	8544	2144	RH10S-33①4L-②-③	8693	2349	RH10U-33①4L-②-③	8985	2421
	RH10D-26①4R-②	7551	3551	RH10S-26①4R-②-③	7666	4010	RH10U-26①4R-②-③	8132	4220
	RH10D-36①4R-②	8828	2428	RH10S-36①4R-②-③	9147	2683	RH10U-36①4R-②-③	9666	2918
	RH10D-52①3N-②	8890	2090	RH10S-52①3N-②-③	9202	2412	RH10U-52①3N-②-③	9723	2211
	RH10D-X5①3N-②	9757	1357	RH10S-X5①3N-②-③	10098	1378	RH10U-X5①3N-②-③	10661	1461
15	RH15D-26①4Q-②	11051	5051	RH15S-26①4Q-②-③	11080	5596	RH15U-26①4Q-②-③	11610	5742
	RH15D-36①4Q-②	12928	3328	RH15S-36①4Q-②-③	13263	3567	RH15U-36①4Q-②-③	13853	3731
20	RH20D-26①3Q-②	14551	6551	RH20S-26①3Q-②-③	14494	7182	RH20U-26①3Q-②-③	15088	7264
	RH20D-36①3Q-②	17028	4228	RH20S-36①3Q-②-③	17379	4451	RH20U-36①3Q-②-③	18040	4544

Table 2-14 Trolley Wheel – Dimensions

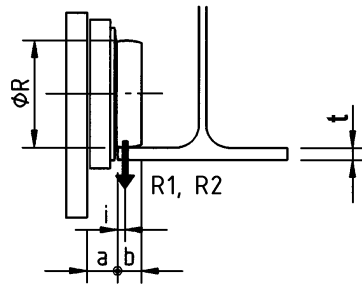

Note:

- See Table 2-13 for reaction forces R1 and R2.

Capacity (Tons)	Product Code		a (in)	b (in)	i (in)	Wheel Dia. ϕR (in)	Maximum Flange Thickness t (in)
	Standard Headroom	Ultra-Low Headroom					
2	RH02S-20①4C-②-③	RH02U-20①4C-②-③	1.38	0.71	0.31	3.94	0.79
	RH02S-29①4C-②-③	RH02U-29①4C-②-③					
	RH02S-20①4D-②-③	RH02U-20①4D-②-③					
	RH02S-29①4D-②-③	RH02U-29①4D-②-③					
	RH02S-39①3A-②-③	RH02U-39①3A-②-③					
	RH02S-79①3A-②-③	RH02U-79①3A-②-③					
3	RH03S-20①4C-②-③	RH03U-20①4C-②-③	1.38	0.71	0.31	3.94	0.79
	RH03S-29①4C-②-③	RH03U-29①4C-②-③					
	RH03S-23①4H-②-③	RH03U-23①4H-②-③					
	RH03S-33①4H-②-③	RH03U-33①4H-②-③					
	RH03S-46①3E-②-③	RH03U-46①3E-②-③					
	RH03S-85①3E-②-③	RH03U-85①3E-②-③					
5	RH05S-23①4G-②-③	RH05U-23①4G-②-③	1.38	1.14	0.47	4.92	0.91
	RH05S-33①4G-②-③	RH05U-33①4G-②-③					
	RH05S-23①4M-②-③	RH05U-23①4M-②-③	1.77	1.50	0.75	7.87	1.50
	RH05S-33①4M-②-③	RH05U-33①4M-②-③	1.38	1.14	0.47	4.92	0.91
	RH05S-46①4J-②-③	RH05U-46①4J-②-③					
	RH05S-92①4J-②-③	RH05U-92①4J-②-③	1.77	1.50	0.75	7.87	1.50
RH05S-52①4P-②-③	RH05U-52①4P-②-③	1.77	1.50	0.75	7.87	1.50	
RH05S-X5①4P-②-③	RH05U-X5①4P-②-③						
7 1/2	RH08S-23①4L-②-③	RH08U-23①4L-②-③	1.77	1.50	0.75	7.87	1.50
	RH08S-33①4L-②-③	RH08U-33①4L-②-③					
	RH08S-23①3M-②-③	RH08U-23①3M-②-③					
	RH08S-33①3M-②-③	RH08U-33①3M-②-③					
	RH08S-52①4N-②-③	RH08U-52①4N-②-③					
	RH08S-X5①4N-②-③	RH08U-X5①4N-②-③					
10	RH10S-23①4L-②-③	RH10U-23①4L-②-③	1.77	1.50	0.75	7.87	1.50
	RH10S-33①4L-②-③	RH10U-33①4L-②-③	1.97	1.69	0.87	9.84	1.69
	RH10S-26①4R-②-③	RH10U-26①4R-②-③					
	RH10S-36①4R-②-③	RH10U-36①4R-②-③	1.77	1.50	0.75	7.87	1.50
	RH10S-52①3N-②-③	RH10U-52①3N-②-③					
RH10S-X5①3N-②-③	RH10U-X5①3N-②-③						
15	RH15S-26①4Q-②-③	RH15U-26①4Q-②-③	1.97	1.69	0.87	9.84	1.69
	RH15S-36①4Q-②-③	RH15U-36①4Q-②-③	1.97	1.69	0.87	9.84	1.69
RH20S-26①3Q-②-③	RH20U-26①3Q-②-③						
20	RH20S-36①3Q-②-③	RH20U-36①3Q-②-③	1.97	1.69	0.87	9.84	1.69
	RH20S-36①3Q-②-③	RH20U-36①3Q-②-③					

3.0 Pre-operational Procedures

3.1 General Information

- 3.1.1 When the RH trolley hoist is incorporated into lifting systems utilizing other equipment, follow and complete all pre-operational procedures and instructions provided with the equipment. Special wiring considerations must also be taken to complete the integration of the RH trolley hoist into the system.
- 3.1.2 The RH is generally delivered pre-assembled and shrink-wrapped on a pallet or in a wooden crate (see Figure 3-1). During shipment and storage prior to installation, the trolley hoist should be kept between -4° and $+140^{\circ}\text{F}$ (-20° and $+60^{\circ}\text{C}$) and the relative humidity must not exceed 80%. The standard packaging is not watertight and rainproof.

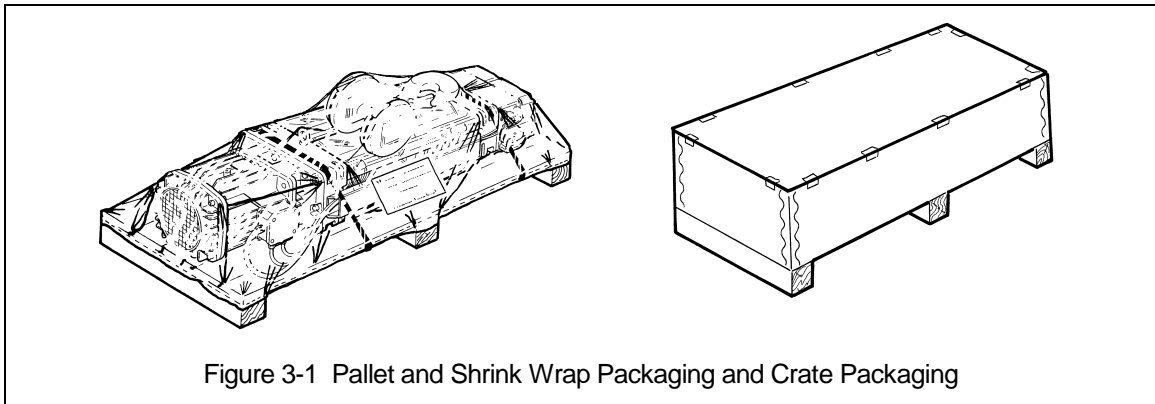

- 3.1.3 The RH trolley hoist is shipped pre-lubricated and the gear box(s) are filled with the correct amount and type of oil. Follow the lubrication requirements in Section 6.1 after the trolley hoist is placed into service.

3.2 Handling

- 3.2.1 Transportation – Move the trolley hoist utilizing a fork lift, pallet jack or hoist/crane system. Do NOT place the trolley hoist on its side (see Figure 3-2). Do NOT stack or place anything on top of the trolley hoist or crate. Avoid swinging and unbalanced conditions (see Figure 3-3).

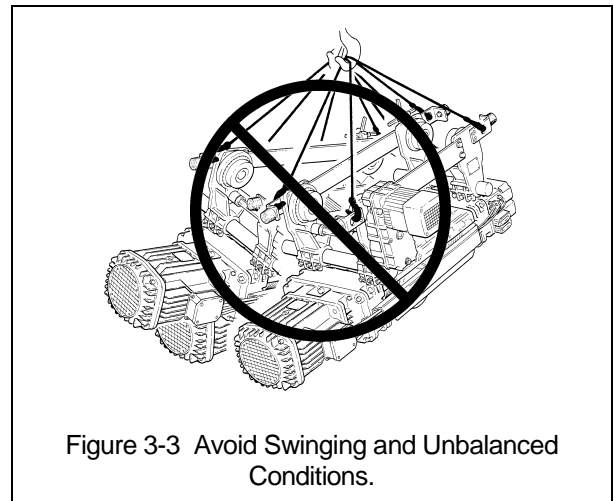
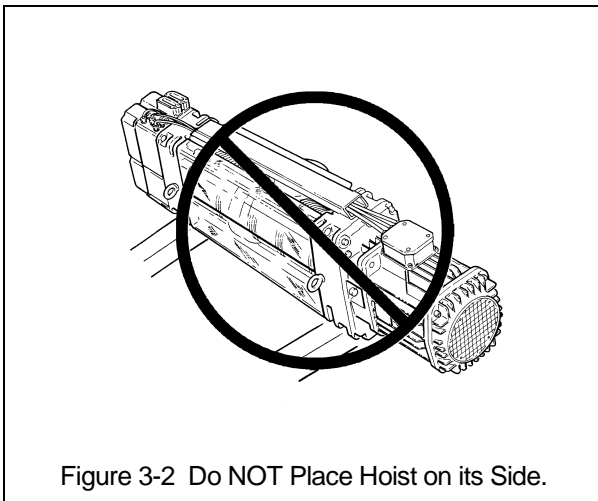

- 3.2.2 Lift points – The deck mounted/lug suspended, standard headroom and ultra-low hoists and trolleys are equipped with lifting lugs to facilitate lifting the trolley hoist with a hoist or crane (see Figure 3-4). During lifting do NOT support the trolley hoist any other way.

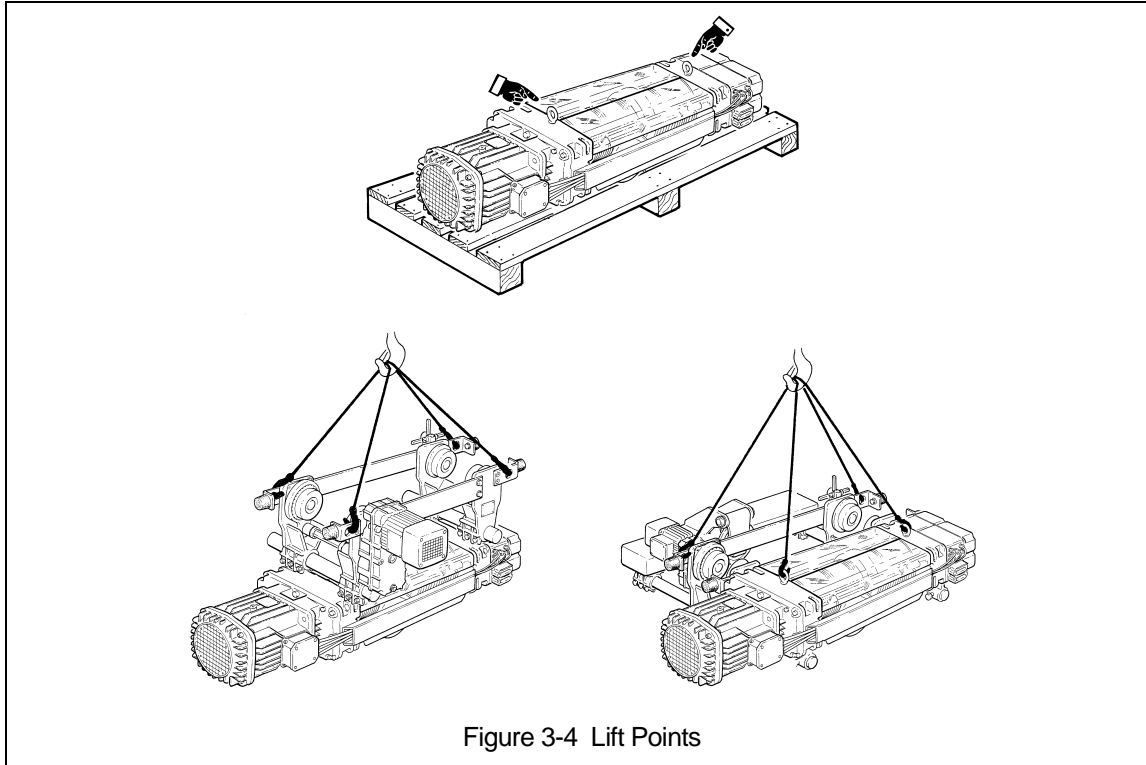

3.3 Mounting Location

- 3.3.1 **⚠ WARNING** Prior to mounting the trolley and hoist ensure that the trolley beam and its supporting structure are adequate to support the trolley, hoist and its loads. If necessary consult a professional that is qualified to evaluate the adequacy of the suspension location and its supporting structure.
- 3.3.2 When the hoist is installed in fixed position or on a trolley not supplied by Harrington, the hoist is designed to be deck mounted OR lug suspended.
- Deck Mounted – The hoist will rest on the four machined surfaces (or “feet”) located on the bottom of the hoist’s cast housing on both ends of the drum.
 - Lug Suspended – The hoist will hang from four slots located on the top of the hoist’s cast housing on both ends of the drum.
- 3.3.3 Optional Eyebolt Kits are available from Harrington and can be used in either the deck mounted or lug suspended configuration (see Figure 3-5). These kits include the Eyebolts and the Flat Washers, Nuts and Jam Nuts sized to fit the Eyebolt and strength requirements of the application. The Eyebolt Pins and keeper hardware is pre-install on the hoist from the factory.
- 3.3.4 For deck mounted configurations the surface(s) on which the hoist rests and is secured to must be level in accordance with Figure 3-6.

3.3.5 Ensure that there is adequate vertical and horizontal clearance along the entire range of the trolley hoist's motion (see Figure 3-7).

3.3.6 **NOTICE** See Section 6.6 for outdoor installation considerations.

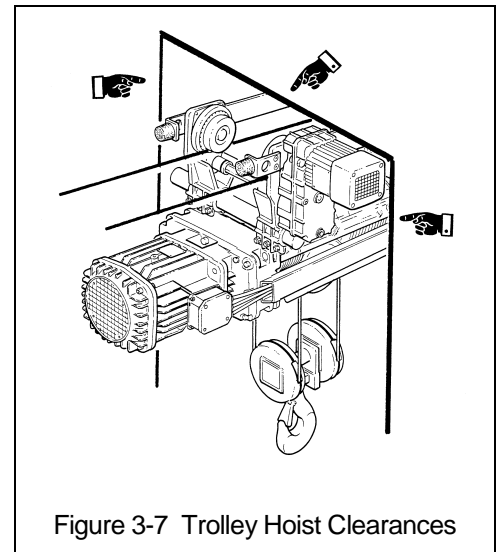
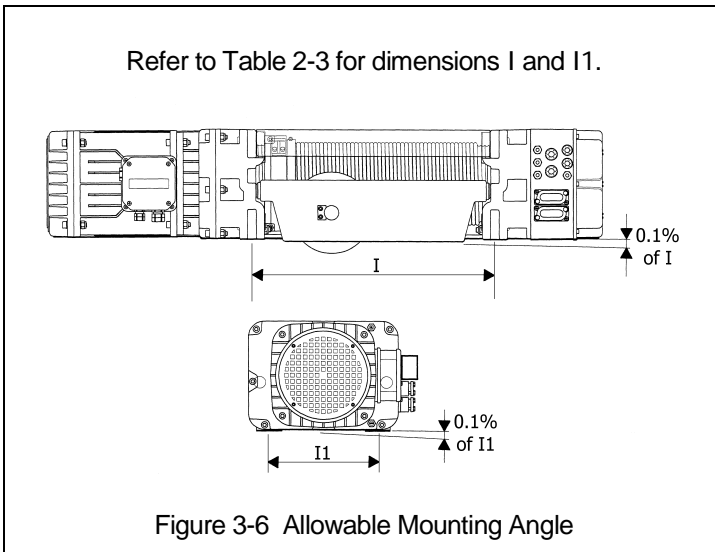
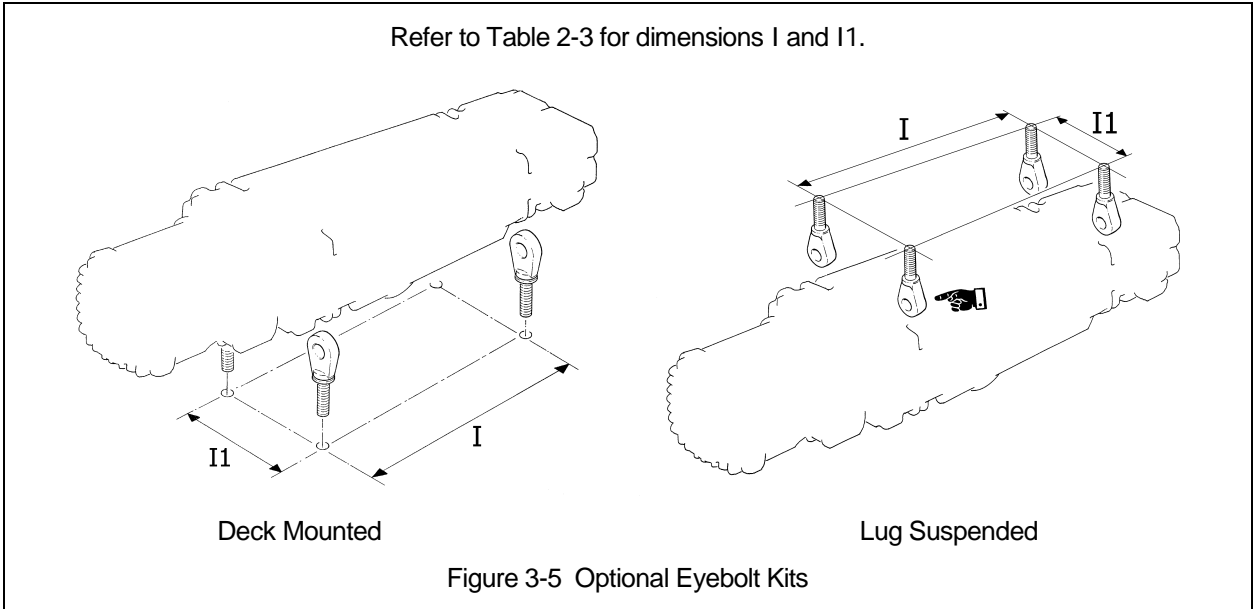

3.4 Assembly, Adjustments and Mounting

3.4.1 Deck mounted configuration installation using the optional Eyebolt kit:

- 1) Make sure the mounting location complies with Section 3.3.
- 2) Refer to Figure 3-8 and Table 3-1.
- 3) With the hoist properly supported (see Section 3.2) remove the Socket Bolts (B), Attachment Plates (C) and Pins (A) from the 4 mounting slots points located on the bottom of the hoist's housing.
- 4) Insert an Eyebolt (D) into one of the slots located on the bottom of the hoist's housing then insert the Pin (A) into the housing and through the hole in the Eyebolt (D).
- 5) Secure the Pin (A) in place with the Attachment Plate (C) and 2 Socket Bolts (B). Torque the Socket Bolts (B) to 50 inch-lbs.
- 6) Repeat steps 4 and 5 for the remaining 3 Eyebolts (D).
- 7) Make sure the Eyebolts (D) are not forced into place and can turn freely on the Pins (A).
- 8) Prepare the mounting surface of the fixed location or trolley with four correctly sized and located mounting holes for the Eyebolts (D).
- 9) Lower the hoist onto the mounting surface or trolley placing one Flat Washer (E) on both sides of the mounting holes. Secure it with the Nuts (F) and Jam Nuts (G). Torque the Nuts (F) (G) to the value shown in Table 3-1 for your hoist.

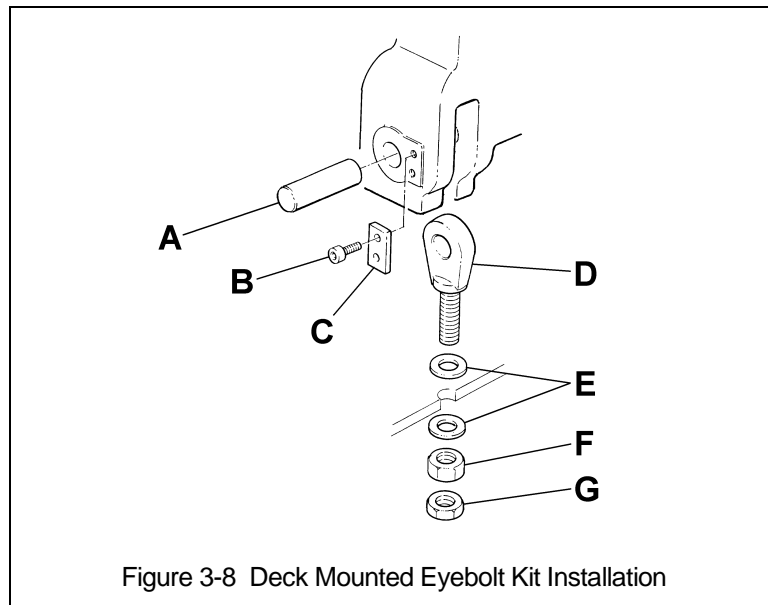

Hoist Size	1	2	3	4
Pin Diameter (mm)	20	25	35	45
Nut (F) Torque (ft-lbs)	166	324	560	1112
Nut (G) Torque (ft-lbs)	166	324	560	1112

3.4.2 Lug suspended configuration installation using the optional Eyebolt kit:

- 1) Make sure the mounting location complies with Section 3.3.
- 2) Refer to Figure 3-9 and Table 3-1.
- 3) With the hoist properly supported (see Section 3.2) remove the 4 Screws (J) and 2 Socket Bolts (K) attaching the Dust Covers (H) and Limit Switch Channel (L). DO NOT remove the bolts attaching the Limit Switches to the Limit Switch Channel and DO NOT remove the Angle Brackets from the hoist body.
- 4) Remove the Socket Bolts (B), Attachment Plates (C) and Pins (A) from the 4 mounting slots points located on the bottom of the hoist's housing.
- 5) Insert an Eyebolt (D) into one of the slots located on the top of the hoist's housing then insert the Pin (A) into the housing and through the hole in the Eyebolt (D).
- 6) Secure the Pin (A) in place with the Attachment Plate (C) and 2 Socket Bolts (B). Torque the Socket Bolts (B) to 50 inch-lbs.
- 7) Repeat steps 4 and 5 for the remaining 3 Eyebolts (D).
- 8) Make sure the Eyebolts (D) are not forced into place and can turn freely on the Pins (A).
- 9) Prepare the mounting surface of the fixed location or trolley with four correctly sized and located mounting holes for the Eyebolts (D).
- 10) Raise the hoist up to the mounting surface or trolley and secure it with the Flat Washers (E), Nuts (F), and Jam Nuts (G). Torque the Nuts (F) (G) to the value shown in Table 3-1 for your hoist.

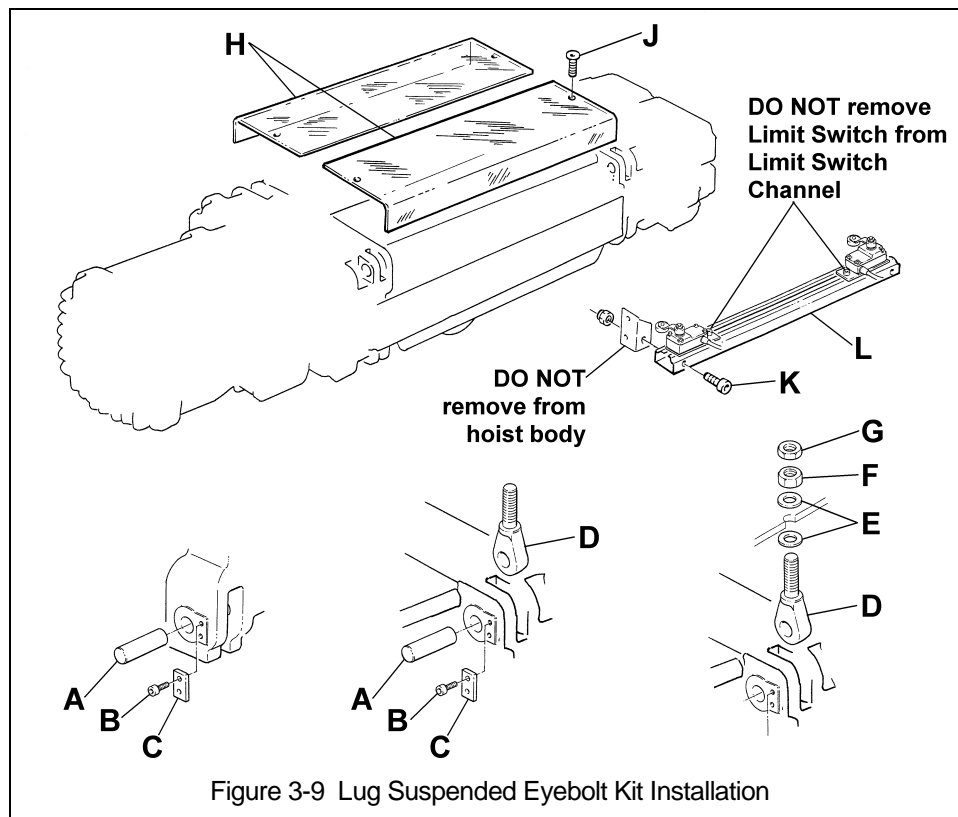

3.4.3 Standard Headroom Trolley Installation

- 1) Make sure the mounting location complies with Section 3.3.
- 2) **NOTICE** Each Stirrups (H) has sufficient clamping force on the Load Bars (J) with only two bolts. The third bolt cannot be installed in some cases because of interference with the suspension of the hoist (see Figure 3-10).
- 3) Install any additional devices, if any (power supply cords or pendants, for instance – see Section 3.5) onto the trolley hoist. If the trolley hoist is not secured to a pallet, place and secure it to one making sure that the trolley hoist is completely stable (see Figure 3-11).
- 4) Remove the Bottom Block from the pallet/packing and place it on the ground. Use a hoist or other suitable lifting means to pickup the Bottom Block if it is heavier than 50 pounds (weight is written on the container if it exceeds 50 pounds). Always lift/hold the Bottom Block from the Hook regardless if it is lifted using a hoist or handled manually (see Figure 3-12).
- 5) **WARNING** When installing the trolley hoist on a beam, ALWAYS raise the hoist into position with the trolley and hoist assembled together and securely attached to a pallet. Raise the trolley and hoist with a forklift, lifting platform, or other similar means. NEVER use slings to raise and install the trolley hoist onto the beam (see Figure 3-13).

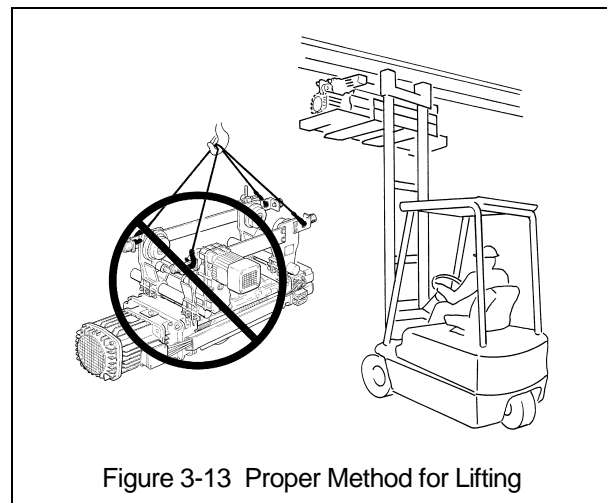
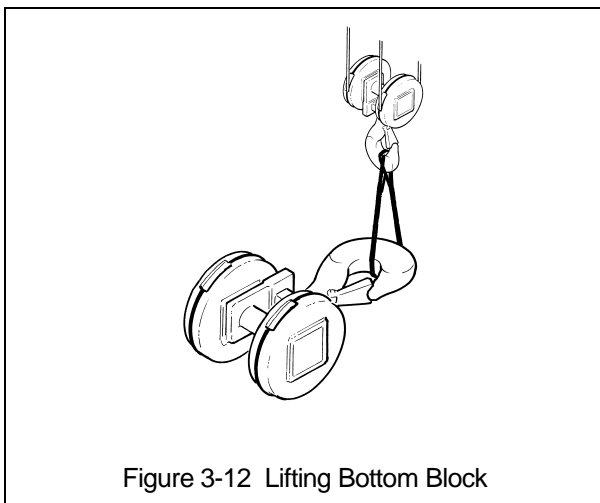
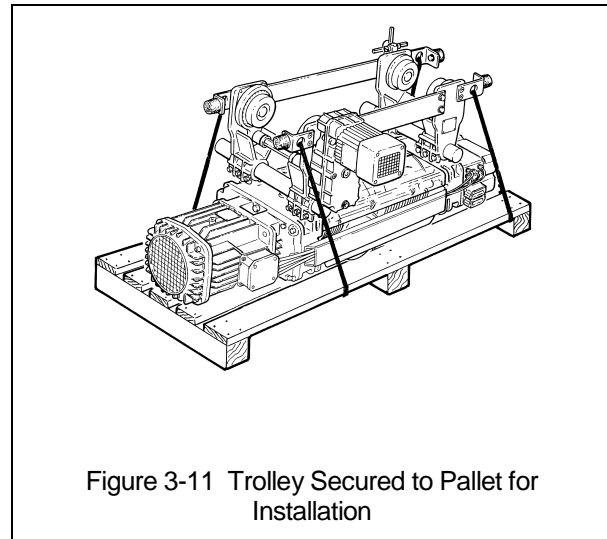
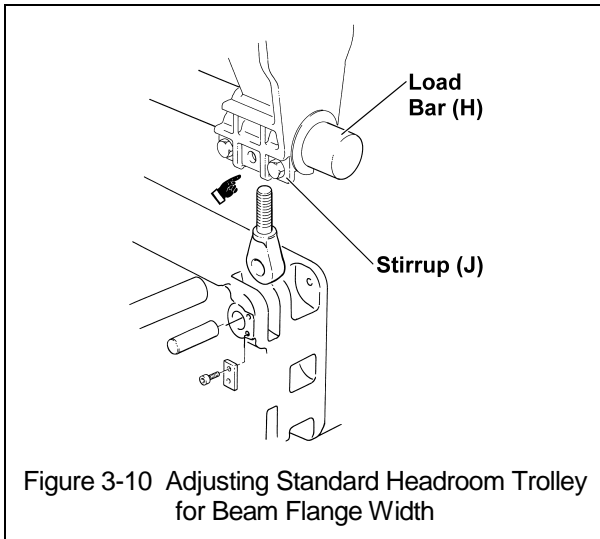

6) Adjust the trolley for the beam's flange width as follows:

- Refer to Table 3-2 and select dimensions "A" and "C" corresponding to the beam's flange width "B".
- Loosen the Screws (D) that attach the Stiffening Plates (E) to Side Plates (F) and loosen the Lock-Nuts (G) on the Stirrups (H) that secure the Side Plates (F) to the Load Bars (J) so that the Side Plates (F) can move freely along the Load Bars (J) (see Figures 3-14 and 3-15).
- Slide the Side Plates (F) along the Load Bars (J) so that dimensions "A" and "C" match the values in Table 3-2 for the beam flange width. Verify that the distance "L" between the trolley wheel flanges is a maximum of 5/32" (4 mm) wider than the beam flange width. Mark the Stirrups (H) locations on the Load Bars (J) for future reference.
- On the Cable Trough side ONLY, use a torque wrench to fully tighten the Screws (D) attaching the Stiffening Plates (E) and the Locking Nuts (G) of stirrups (H) to the specified torque values shown in the Table 3-3.

Table 3-2 Standard Headroom Trolley Adjustment Dimension																
Beam Flange, B		Adjustment Dimension (Inch)														
		Trolley Size 1				Trolley Size 2				Trolley Size 3				Trolley Size 4		
		Hoist Size 1 4/1		Hoist Size 1 2/1		Hoist Size 2 2/1		Hoist Size 2 4/1		Hoist Size 3 2/1		Hoist Size 3 4/1		Hoist Size 4 2/1		Hoist Size 4 4/1
(mm)	(inch)	A	C	A	C	A	C	A	C	A	C	A	C	A	C	
90,91	3 9/16	6.21	4.00	5.70	4.51	6.29	3.92									
98	3 7/8	6.05	3.84	5.54	4.35	6.13	3.77									
100	3 15/16	6.02	3.81	5.51	4.32	6.10	3.74									
102	4	5.99	3.78	5.48	4.29	6.07	3.70									
106	4 3/16	5.90	3.69	5.39	4.20	5.98	3.61									
110	4 5/16	5.84	3.62	5.32	4.14	5.91	3.55									
113	4 7/16	5.77	3.56	5.26	4.07	5.85	3.49									
119	4 11/16	5.65	3.44	5.14	3.95	5.73	3.36	4.95	3.35	6.52	3.35					
120	4 3/4	5.62	3.41	5.10	3.92	5.70	3.33	4.92	3.32	6.49	3.32					
125	4 15/16	5.52	3.31	5.01	3.82	5.60	3.24	4.82	3.23	6.40	3.23					
127	5	5.49	3.28	4.98	3.79	5.57	3.20	4.79	3.19	6.37	3.19					
131	5 3/16	5.40	3.19	4.89	3.70	5.48	3.11	4.70	3.10	6.27	3.10					
135	5 1/8	5.34	3.13	4.82	3.64	5.41	3.05	4.64	3.04	6.21	3.04	4.95	3.12	6.60	3.05	
137	5 1/4	5.30	3.09	4.79	3.61	5.38	3.02	4.61	3.01	6.18	3.01	4.91	3.09	6.57	3.01	
140	5 1/2	5.24	3.03	4.73	3.54	5.32	2.96	4.54	2.94	6.12	2.94	4.85	3.03	6.51	2.95	

Table 3-2 Standard Headroom Trolley Adjustment Dimension (continued)

Beam Flange, B (mm) (inch)		Adjustment Dimension (Inch)															
		Trolley Size 1						Trolley Size 2				Trolley Size 3				Trolley Size 4	
		Hoist Size 1 4/1		Hoist Size 1 2/1		Hoist Size 2 2/1		Hoist Size 2 4/1		Hoist Size 3 2/1		Hoist Size 3 4/1		Hoist Size 4 2/1		Hoist Size 4 4/1	
A	C	A	C	A	C	A	C	A	C	A	C	A	C	A	C		
143	5 5/8	5.18	2.97	4.67	3.48	5.26	2.89	4.48	2.88	6.06	2.88	4.79	2.97	6.44	2.89		
149	5 7/8	5.05	2.85	4.54	3.36	5.13	2.77	4.36	2.76	5.93	2.76	4.66	2.84	6.32	2.77		
150	8 15/16	5.02	2.81	4.51	3.33	5.10	2.74	4.32	2.73	5.90	2.73	4.63	2.81	6.29	2.73		
153	6	4.99	2.78	4.48	3.29	5.07	2.71	4.29	2.69	5.87	2.69	4.60	2.78	6.25	2.70		
155	6 1/8	4.93	2.72	4.42	3.23	5.01	2.64	4.23	2.63	5.81	2.63	4.54	2.72	6.19	2.64		
160	6 5/16	4.84	2.63	4.32	3.14	4.91	2.55	4.14	2.54	5.71	2.54	4.44	2.63	6.10	2.55		
163	6 7/16	4.77	2.56	4.26	3.08	4.85	2.49	4.07	2.48	5.65	2.48	4.38	2.56	6.04	2.49		
170	6 11/16	4.65	2.44	4.14	2.95	4.73	2.36	3.95	2.35	5.52	2.35	4.26	2.44	5.91	2.36	4.33	2.36
175	6 7/8	4.55	2.35	4.04	2.86	4.63	2.27	3.86	2.26	5.43	2.26	4.16	2.35	5.82	2.27	4.24	2.27
178	7	4.49	2.28	3.98	2.80	4.57	2.21	3.79	2.19	5.37	2.19	4.10	2.28	5.75	2.20	4.18	2.21
180	7 1/16	4.46	2.25	3.95	2.76	4.54	2.18	3.76	2.16	5.34	2.16	4.07	2.25	5.72	2.17	4.15	2.18
181	7 1/8	4.43	2.22	3.92	2.73	4.51	2.14	3.73	2.13	5.31	2.13	4.04	2.22	5.69	2.14	4.11	2.15
184	7 1/4	4.37	2.16	3.86	2.67	4.45	2.08	3.67	2.07	5.24	2.07	3.97	2.16	5.63	2.08	4.05	2.08
185	7 5/16	4.34	2.13	3.82	2.64	4.41	2.05	3.64	2.04	5.21	2.04	3.94	2.13	5.60	2.05	4.02	2.05
190	7 1/2	4.24	2.03	3.73	2.55	4.32	1.96	3.54	1.94	5.12	1.94	3.85	2.03	5.50	1.96	3.93	1.96
200	7 7/8	4.06	1.85	3.54	2.36	4.13	1.77	3.36	1.76	4.93	1.76	3.66	1.85	5.31	1.77	3.74	1.77
203	8	3.99	1.79	3.48	2.30	4.07	1.71	3.29	1.69	4.87	1.69	3.60	1.79	5.25	1.71	3.68	1.71
210	8 1/4	3.87	1.66	3.36	2.17	3.95	1.58	3.17	1.57	4.74	1.57	3.47	1.66	5.13	1.58	3.55	1.58
215	8 7/16	3.77	1.57	3.26	2.08	3.85	1.49	3.07	1.48	4.65	1.48	3.38	1.57	5.03	1.49	3.46	1.49
220	8 11/16	3.65	1.44	3.14	1.95	3.73	1.36	2.95	1.35	4.52	1.35	3.25	1.44	4.91	1.36	3.33	1.36
229	9	3.49	1.29	2.98	1.80	3.57	1.21	2.79	1.19	4.37	1.19	3.10	1.29	4.75	1.21	3.18	1.21
232	9 1/8	3.43	1.22	2.92	1.74	3.51	1.15	2.73	1.13	4.31	1.13	3.03	1.22	4.69	1.15	3.11	1.15
240	9 7/16	3.27	1.07	2.76	1.58	3.35	0.99	2.57	0.98	4.15	0.98	2.88	1.07	4.53	0.99	2.96	0.99
250	9 7/8	3.06	0.85	2.54	1.36	3.13	0.77	2.36	0.76	3.93	0.76	2.66	0.85	4.31	0.77	2.74	0.77
254	10	2.99	0.79	2.48	1.30	3.07	0.71	2.29	0.69	3.87	0.69	2.60	0.79	4.25	0.71	2.68	0.71
257	10 1/8	2.93	0.73	2.42	1.24	3.01	0.65	2.23	0.63	3.81	0.63	2.53	0.73	4.19	0.65	2.61	0.65
260	10 1/4	2.87	0.66	2.36	1.18	2.95	0.58	2.17	0.57	3.74	0.57	2.47	0.66	4.12	0.59	2.55	0.58
264	10 3/8	2.81	0.60	2.29	1.11	2.88	0.52	2.11	0.51	3.68	0.51	2.41	0.60	4.06	0.52	2.49	0.52
267	10 1/2	2.74	0.54	2.23	1.05	2.82	0.46	2.04	0.44	3.62	0.44	2.35	0.54	4.00	0.46	2.43	0.46
280	11	2.49	0.29	1.98	0.80	2.57	0.21	1.79	0.19	3.37	0.19	2.10	0.29	3.75	0.21	2.18	0.21
283	11 1/8	4.79	2.59	4.28	3.10	4.87	2.51	4.08	2.51	5.66	2.51	4.40	2.59	6.05	2.51	4.48	2.51
286	11 1/4	4.73	2.52	4.22	3.04	4.81	2.45	4.02	2.45	5.60	2.45	4.34	2.52	5.99	2.45	4.41	2.45
289	11 3/8	4.67	2.46	4.16	2.97	4.75	2.38	3.96	2.38	5.53	2.38	4.27	2.46	5.93	2.38	4.35	2.38
295	11 5/8	4.54	2.34	4.03	2.85	4.62	2.26	3.83	2.26	5.41	2.26	4.15	2.34	5.80	2.26	4.23	2.26
298	11 3/4	4.48	2.27	3.97	2.79	4.56	2.20	3.77	2.20	5.35	2.20	4.09	2.27	5.74	2.20	4.16	2.20
300	11 13/16	4.45	2.24	3.94	2.76	4.53	2.16	3.74	2.16	5.31	2.16	4.05	2.24	5.71	2.16	4.13	2.16
302	11 7/8	4.42	2.21	3.91	2.72	4.50	2.13	3.71	2.13	5.28	2.13	4.02	2.21	5.68	2.13	4.10	2.13
305	12	4.35	2.15	3.84	2.66	4.43	2.07	3.65	2.07	5.22	2.07	3.96	2.15	5.61	2.07	4.04	2.07
314	12 3/8	4.17	1.96	3.66	2.47	4.25	1.88	3.46	1.88	5.03	1.88	3.77	1.96	5.43	1.88	3.85	1.88
316	12 7/16	4.14	1.93	3.62	2.44	4.21	1.85	3.43	1.85	5.00	1.85	3.74	1.93	5.40	1.85	3.82	1.85
318	12 1/2	4.10	1.90	3.59	2.41	4.18	1.82	3.40	1.82	4.97	1.82	3.71	1.90	5.36	1.82	3.79	1.82
324	12 3/4	3.98	1.77	3.47	2.29	4.06	1.70	3.27	1.70	4.85	1.70	3.59	1.77	5.24	1.70	3.66	1.70
327	12 7/8	3.92	1.71	3.41	2.22	4.00	1.63	3.21	1.63	4.78	1.63	3.52	1.71	5.18	1.63	3.60	1.63
330	13	3.85	1.65	3.34	2.16	3.93	1.57	3.15	1.57	4.72	1.57	3.46	1.65	5.11	1.57	3.54	1.57
350	13 3/4	3.48	1.27	2.97	1.79	3.56	1.20	2.77	1.20	4.35	1.20	3.09	1.27	4.74	1.20	3.16	1.20
356	14	3.35	1.15	2.84	1.66	3.43	1.07	2.65	1.07	4.22	1.07	2.96	1.15	4.61	1.07	3.04	1.07
368	14 1/2	3.10	0.90	2.59	1.41	3.18	0.82	2.40	0.82	3.97	0.82	2.71	0.90	4.36	0.82	2.79	0.82
381	15	2.85	0.65	2.34	1.16	2.93	0.57	2.15	0.57	3.72	0.57	2.46	0.65	4.11	0.57	2.54	0.57
384	15 1/8	2.79	0.59	2.28	1.10	2.87	0.51	2.08	0.51	3.66	0.51	2.40	0.59	4.05	0.51	2.48	0.51
400	15 3/4	2.48	0.27	1.97	0.79	2.56	0.20	1.77	0.20	3.35	0.20	2.09	0.27	3.74	0.20	2.16	0.20

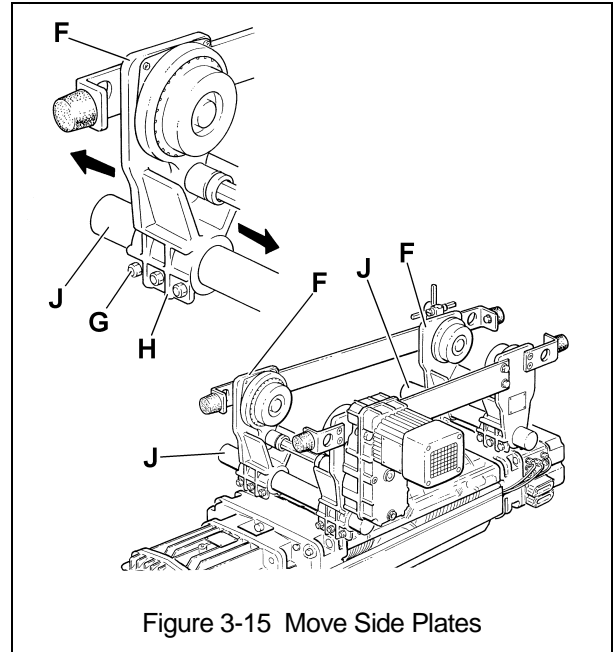
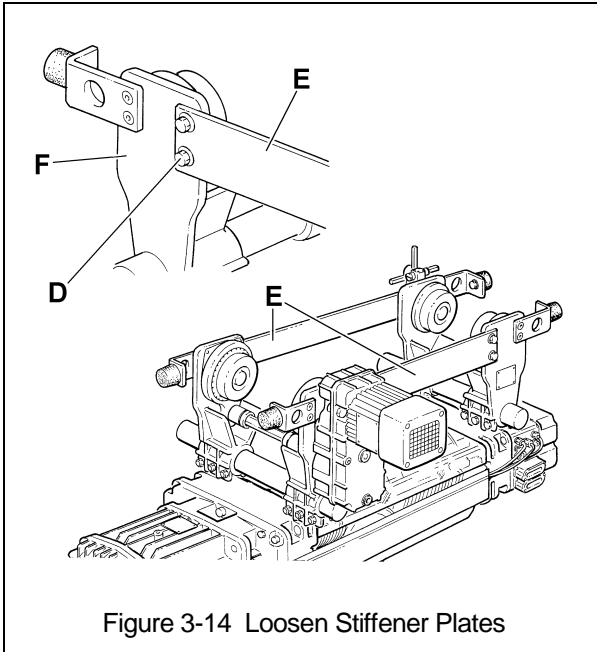

- 7) Using a forklift or another suitable means, position the pallet so that the horizontal axis of the beam is parallel to the horizontal axis of the hoist (see Figure 3-16).
- 8) Temporarily slide the Side Plates (F) OPPOSITE the trolley motor(s) along the Load Bars (J) so that the Distance between the faces of the trolley wheel is wider than the beam flange (see Figure 3-17).
- 9) **⚠ WARNING** This applies to standard headroom trolleys only. When preparing the trolley for placement on the beam, ALWAYS move the Side Plates (F) opposite the traversing motor side. DO NOT move the Side Plates (F) on the trolley motor side.
- 10) Use a moveable scaffolding or a lifting platform so that one person can reach the height of the beam and guide the forklift operator. Raise the pallet slowly and carefully avoiding any swinging or oscillations until the trolley hoist reaches the bottom flange beam.
- 11) Guiding the fork lift operator, slowly raise the pallet while keeping it level until the running surface of the trolley wheels are above the bottom flange of the beam. Then move the pallet horizontally until the trolley wheels on the trolley motor side are over the bottom flange.
- 12) From the scaffolding or lifting platform, slide the previously moved Side Plates (F) along the Load Bars (J) until the trolley wheels are over the beam flange and the Stirrups (H) are lined up with the previously made marks (step 6 above) on the Load Bars (J) (see Figure 3-18).
- 13) Lower the pallet just enough until the trolley wheels are resting on the beam flange.
- 14) Check that all 4 trolley wheels rest correctly on the beam and that the clearance between the wheel flange and the edge of the beam is 5/64 inch (2 mm) maximum at all 4 wheels (see Figure 3-19).
- 15) Remove the straps/ropes securing the trolley hoist to the pallet and lower the pallet to the ground.
- 16) Using a torque wrench, fully tighten the Screws (D) attaching the Stiffening Plates (E) and the Locking Nuts (G) of Stirrups (H) to the specified torque values shown in the Table 3-3.

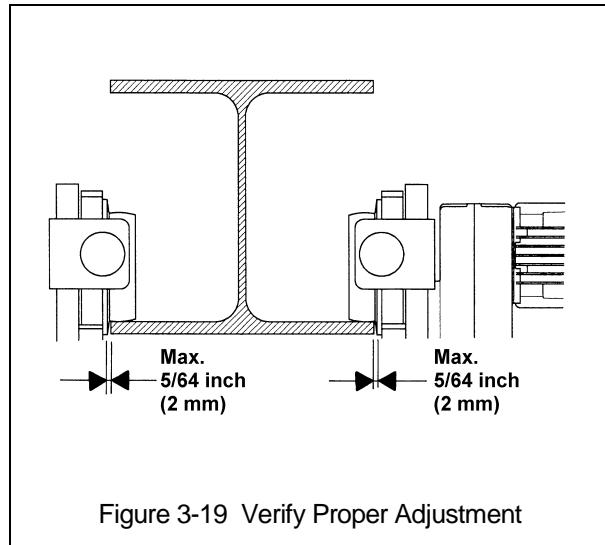
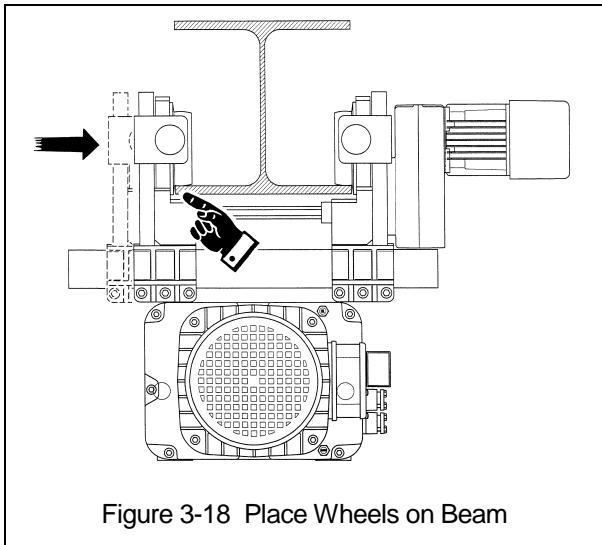
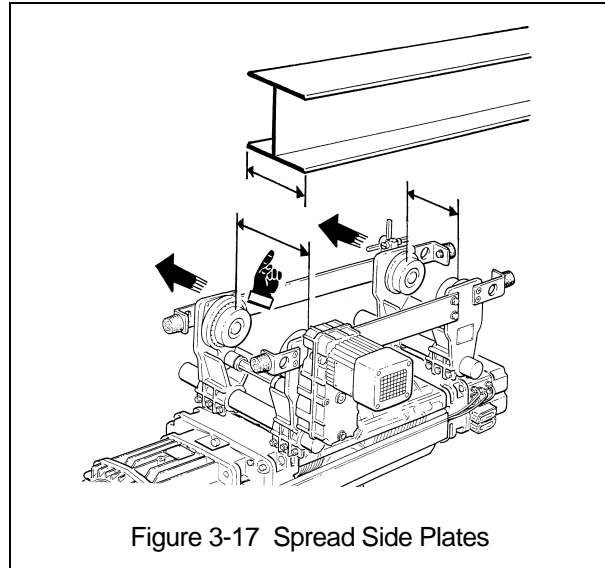
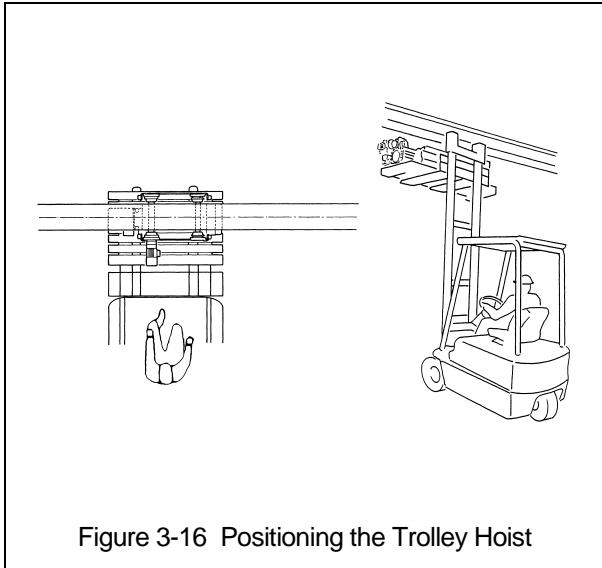
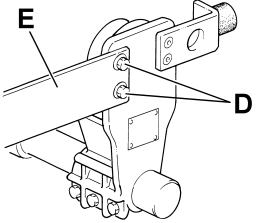
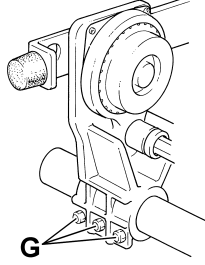

Table 3-3 Torque Values

	Torque Value (ft-lbs)			
Trolley Size	1	2	3	4
Load Bar Lock-Nuts (G)	23	39	94	184
Stiffener Screws (D)	9	18	49	75

3.4.4 Ultra-Low Headroom Trolley Installation

- 1) Make sure the mounting location complies with Section 3.3.
- 2) Install any additional devices, if any (power supply cords or pendants, for instance – see Section 3.5) onto the trolley hoist. If the trolley hoist is not secured to a pallet, place and secure it to one making sure that the trolley hoist is completely stable (see Figure 3-20).
- 3) Remove the Bottom Block from the pallet/packing and place it on the ground. Use a hoist or other suitable lifting means to pickup the Bottom Block if it is heavier than 50 pounds (weight is written on the container if it exceeds 50 pounds). Always lift/hold the Bottom Block from the Hook regardless if it is lifted using a hoist or handled manually (see Figure 3-21).
- 4) On the counterweight side, loosen the Screws (D) that attach the Stiffening Plates (E) to Side Plates (F) and loosen the Lock-Nuts (G) on the Stirrups (H) that secure the Side Plates (F) to the Load Bars (J) (see Figure 3-24).
- 5) Remove the Nuts (K) and Socket Bolts (L) to remove the Spacers (M) from the Stirrups (H) so that the Side Plates (F) on the counterweight side can move freely along the Load Bars (J) (see Figure 3-25).
- 6) For relatively small beam flange widths (at the lower end of the flange range – see Table 2-8), the trolley Drive Shaft must be shortened to allow the Side Plates (F) to adjust close enough together as required. Drive the Spring Pin attaching the Drive Pinion, slide the counterweight side Side Plates (F) out and remove the Drive Shaft. After cutting the Drive Shaft, reinstall it onto the trolley and reattach the Drive Pinion.

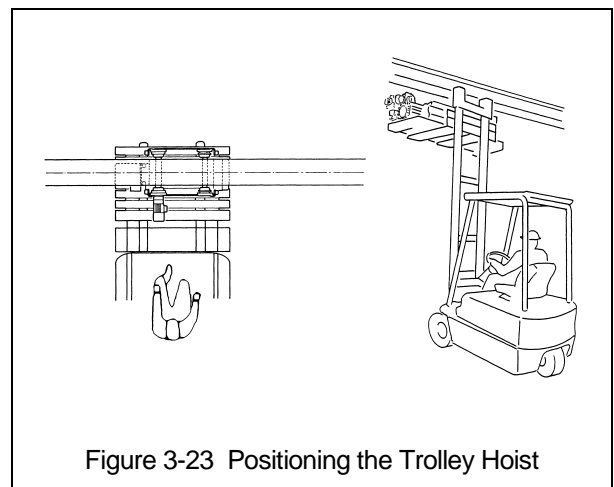
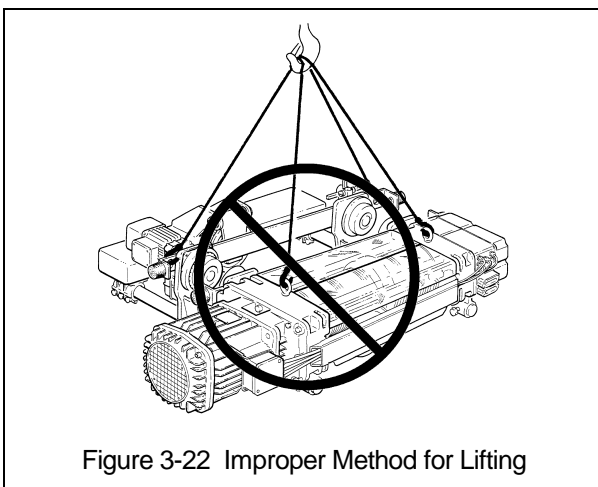
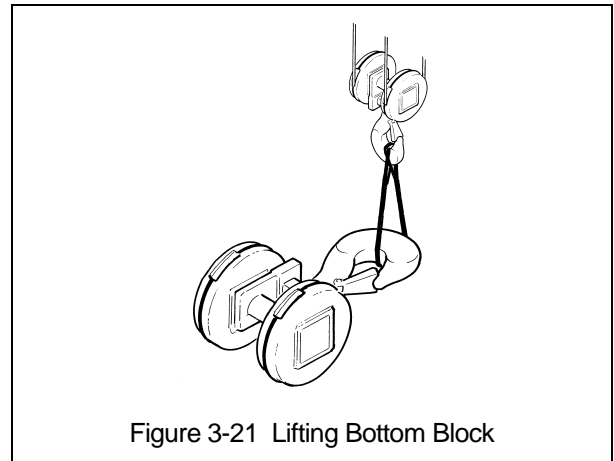
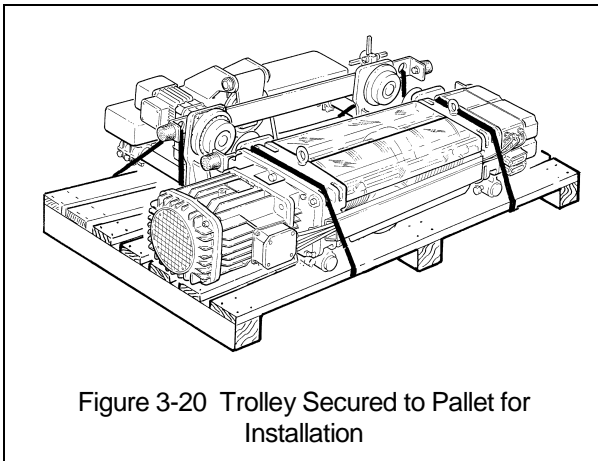

- 7) **⚠️ WARNING** When installing the trolley hoist on a beam, ALWAYS raise the hoist into position with the trolley and hoist assembled together and securely attached to a pallet. Raise the trolley and hoist with a forklift, lifting platform, or other similar means. NEVER use slings to raise and install the trolley hoist onto the beam (see Figure 3-22).
- 8) Using a forklift or another suitable means, position the pallet so that the horizontal axis of the beam is parallel to the horizontal axis of the hoist (see Figure 3-23).
- 9) Temporarily slide the Side Plates (F) on the counterweight side along the Load Bars (J) so that the distance between the faces of the trolley wheel is wider than the beam flange (see Figure 3-26).
- 10) **⚠️ WARNING** This applies to ultra-low headroom trolleys only. When preparing the trolley for placement on the beam, ALWAYS move the Side Plates (F) on the counterweight side, DO NOT remove the Side Plates (F) on the hoist side. DO NOT remove the counterweight.
- 11) Use a movable scaffolding or a lifting platform so that one person can reach the height of the beam and guide the forklift operator. Raise the pallet slowly and carefully avoiding any swinging or oscillations until the trolley hoist reaches the bottom flange beam.
- 12) Guiding the fork lift operator, slowly raise the pallet while keeping it level until the running surface of the trolley wheels are above the bottom flange of the beam. Then move the pallet horizontally until the trolley wheels on the hoist side are over the bottom flange.
- 13) From the scaffolding or lifting platform, slide the previously moved Side Plates (F) along the Load Bars (J) until the trolley wheels are over the beam flange and the trolley wheel flanges of the Side Plates (F) on the counterweight side are very close to the edge of the beam flange (see Figure 3-27).

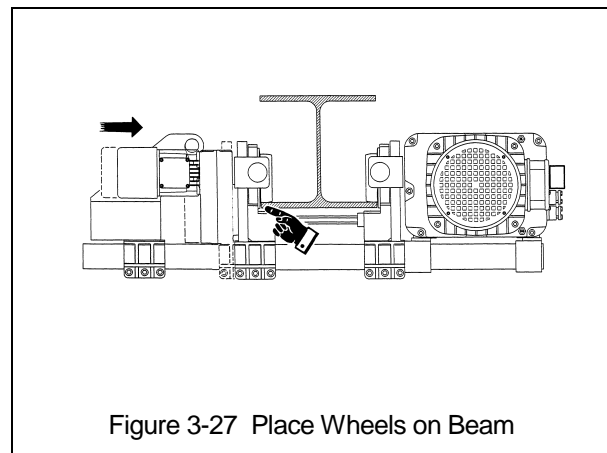
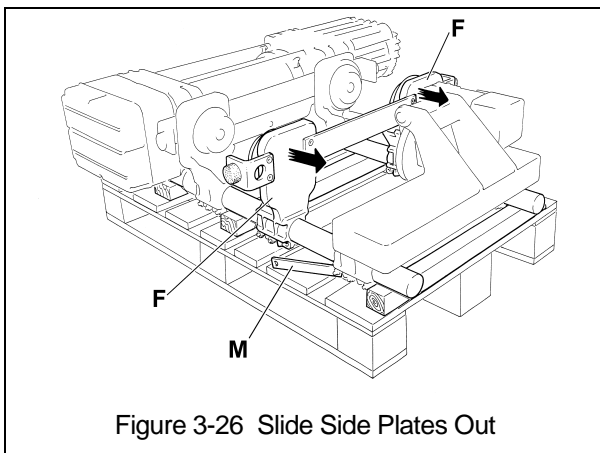
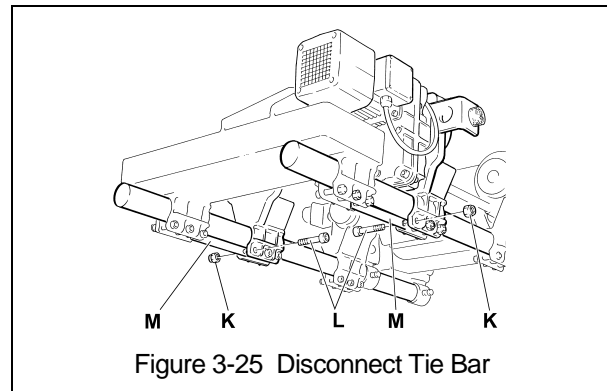
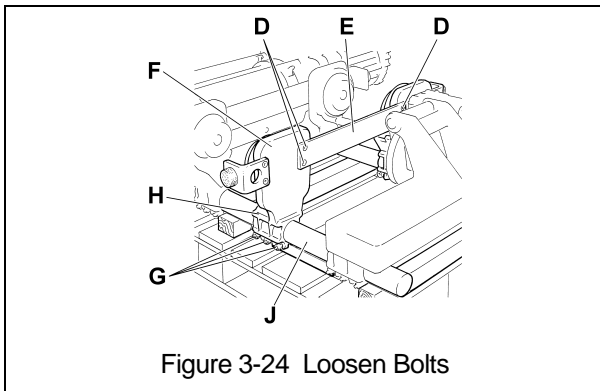

- 14) Lower the pallet just enough until the trolley wheels are resting on the beam flange.
- 15) Check that all 4 trolley wheels rest correctly on the beam and that the clearance between the wheel edge and the edge of the beam is 5/64 inch (2 mm) maximum at all 4 wheels (see Figure 3-28).
- 16) Remove the straps/ropes securing the trolley hoist to the pallet and lower the pallet to the ground.
- 17) Reattach the Spacers (M) to the Stirrups (F).
- 18) Using a torque wrench, fully tighten the Screws (D) attaching the Stiffening Plates (E) and the Locking Nuts (G) of Stirrups (H) to the specified torque values shown in the Table 3-4.

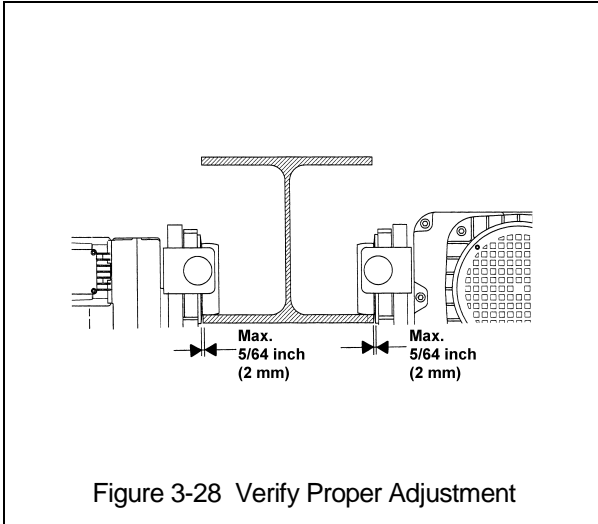

Table 3-4 Torque Values

	Torque Value (ft-lbs)			
	1	2	3	4
Load Bar Lock-Nuts (G)	23	39	94	184
Stiffener Screws (D)	9	18	49	75

3.5 Electrical Connections

3.5.1 **⚠ CAUTION** Ensure that the voltage of the electric power supply is proper for the hoist or trolley.

3.5.2 **⚠ CAUTION** Do NOT apply electronic soft-start control or voltage varying controls to the RH's lifting or traversing motors. Use of such devices may cause the motor brake and other electrical components to malfunction. For variable frequency drives contact Harrington for more information.

3.5.3 **⚠ DANGER** Before proceeding, ensure that the electrical supply for the hoist or trolley has been de-energized (disconnected). Lock out and tag out in accordance with ANSI Z244.1 "Personnel Protection -Lockout/Tagout of Energy Sources".

3.5.4 Installing Power Supply Cord

- 1) Refer to Figure 3-29 and the wiring diagram provided with the Hoist.
- 2) Remove Control Cover (A) or open the metal electric enclosure.
- 3) Loosen the Cable Fitting (C) located on the left side of the electrical enclosure and insert the power supply cord. Pull through enough cord to reach the Power Supply Terminal (D) then securely tighten the Cable Fitting (C).
- 4) Connect the 3 phase power leads (L1, L2 and L3) and the ground lead of the Power Supply Cord to the Power Supply Terminal. Make sure the terminals are securely tighten and each lead is completely isolated.
- 5) Replace the Control Cover (A) or close the metal electrical enclosure. Be careful to not damage the seal or sealing surfaces and make sure to securely tighten all fasteners or latches.

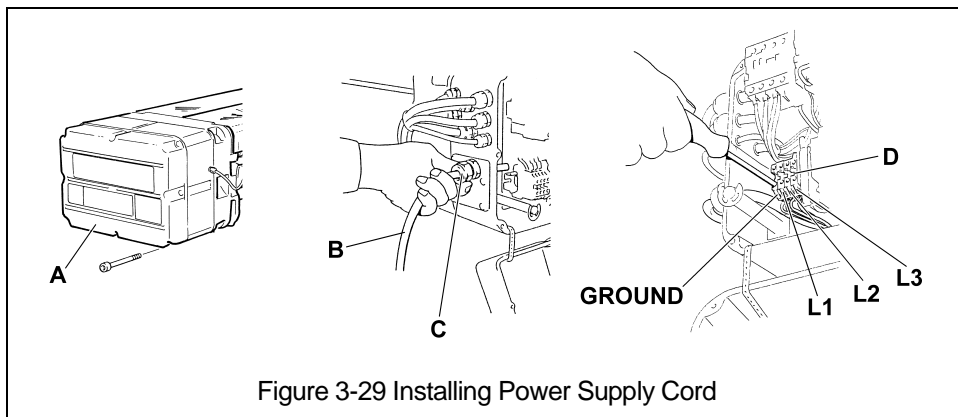

3.5.5 Installing Pendant

- 1) Refer to Figure 3-30, the wiring diagram and the interconnection diagram provided with the Hoist.
- 2) Remove Control Cover (A) or open the metal electrical enclosure.
- 3) Access to Terminal Strip: For hoists with metal electrical enclosure the terminal strips are accessible upon opening the enclosure lid. For hoists with the integral electrical enclosures (plastic cover), the Terminal Strips are located on the back side of the Panel (F). Gain access by removing the Socket Bolts (E) securing the Panel (F), loosening the Set Bolts (G) on the Support Bars (H), then slide and rotate the Panel (F) forward.
- 4) Loosen the Cable Fitting (C) located on the left side of the electrical enclosure and insert the pendant cord. Pull through enough cord to reach the terminals then securely tighten the Cable Fitting (C).
- 5) Attach a strain relief cable or chain between the pendant and hoist. The cord or chain should attach to the Small plate or eyebolt located at the bottom of the electrical enclosure.
- 6) Connect the individual pendant leads to the correct terminals as shown on the interconnection diagram. Make sure the terminals are securely tightened and each lead is completely isolated.
- 7) Reattach the Control Panel (F) and replace the Control Cover (A) or close the metal electrical enclosure. Be careful to not damage the seal or sealing surfaces and make sure to securely tighten all fasteners or latches.

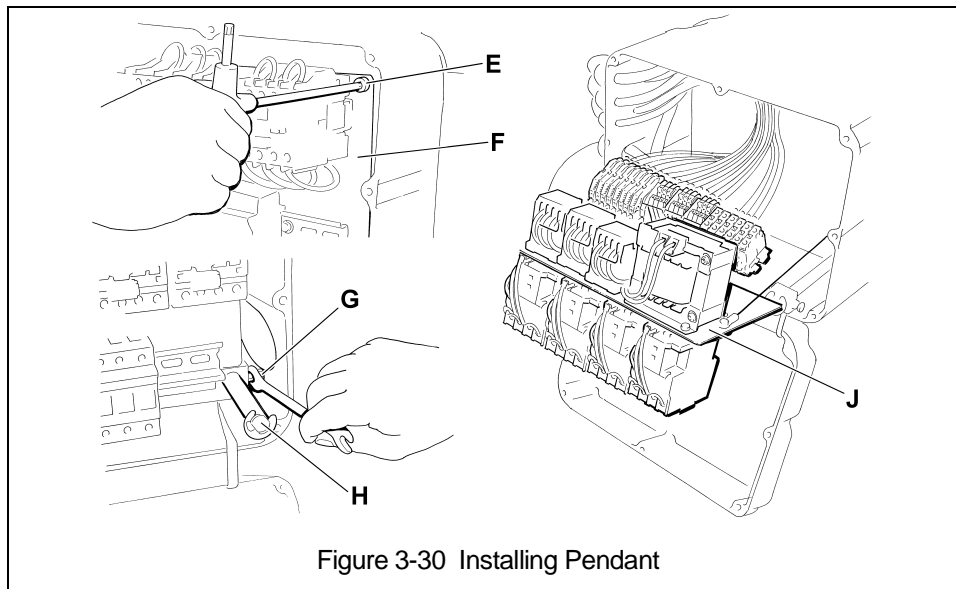

- 3.5.6 Connection to Electrical Power Source - The 3 power leads of the Power Supply Cable (normally red, white, and black wires) should be connected to an Electric Power Disconnect Switch or Circuit Breaker. This connection should be made so that the hoist is phased properly. Refer to Section 3.7.4 for instructions on how to check for correct power supply phase connection.
- 3.5.7 Fuse/Breaker Capacity - The trolley and hoist's power supply should be equipped with overcurrent protection such as fuses, which should be selected for 110% to 120% of total listed full load amperage, and should be dual element time-delay fuses. For the total full load amperage draw, add the amperage draws shown on the motor nameplates of ALL lifting and traversing motors.
- 3.5.8 **⚠ DANGER** Grounding - An improper or insufficient ground connection creates an electrical shock hazard when touching any part of the hoist or trolley. In the Power Supply Cable the ground wire will be either Green with Yellow stripe or solid Green. It should always be connected to a suitable ground connection. Do not paint the trolley wheel running surfaces of the beam as this can affect grounding.

3.6 Reeving and Adjustments

3.6.1 Reeving the bottom hook

- 1) Working from a scaffolding or lifting platform, remove the Retaining Ring (B) and Load Limiter Pin (D) from the Terminal Head Crossbar (A). Let the Load Limiter (C) rotate downward and remove the Terminal Head (F) from the Load Limiter (C) by pulling out the Terminal Head Pin (E). (see Figure 3-31).
- 2) From the ground, press the down button on the pendant until there is sufficient rope unwound to reeve the hoist. Take care not to activate the down limit switch.
- 3) Place the Bottom Block on the ground so that it is positioned perpendicular to the hoist, and insert the rope end into the bottom block as shown in Figure 3-32 for 2/1 and 4/1 reeved hoists (2 or 4 rope-falls). To make rope insertion easier, temporarily attach a wire to the end of the rope with adhesive tape and use the wire to pull the rope through the Bottom Block. Securely tie a string or cord to the end of the rope and pull the wire rope up to the hoist from the scaffolding/platform. For 4/1 reeved hoists thread the rope through the return pulley installed in the hoist, then back through the Bottom Block (see Figure 3-32).
- 4) Insert the end of the rope into the Terminal Head (F) and making sure at least 4 inches of rope extend beyond the Terminal Head (F). Install the Wedge (G) into the Terminal Head (F) and pull the rope until the Wedge (G) and the rope are tightly seated in the Terminal Head (F) (Figure 3-33).
- 5) **⚠ WARNING** Make certain the wire rope is tight against the Wedge (G) in the Terminal Head (F).
- 6) Attach the Rope Clamp (H) 2 inches from the Terminal Head (F) and fully tighten the nuts. Do NOT clamp the free end of the rope to the load bearing rope fall (the rope between the Terminal Head (F) and the Bottom Block) (Figure 3-34).
- 7) Reattach the Terminal Head (F) to the Load Limiter (C) with the Terminal Head Pin (E) and reattach the Load Limiter (C) to the Terminal Head Crossbar (A) using the Load Limiter Pin (D) and Retaining ring (B) (Figure 3-35).

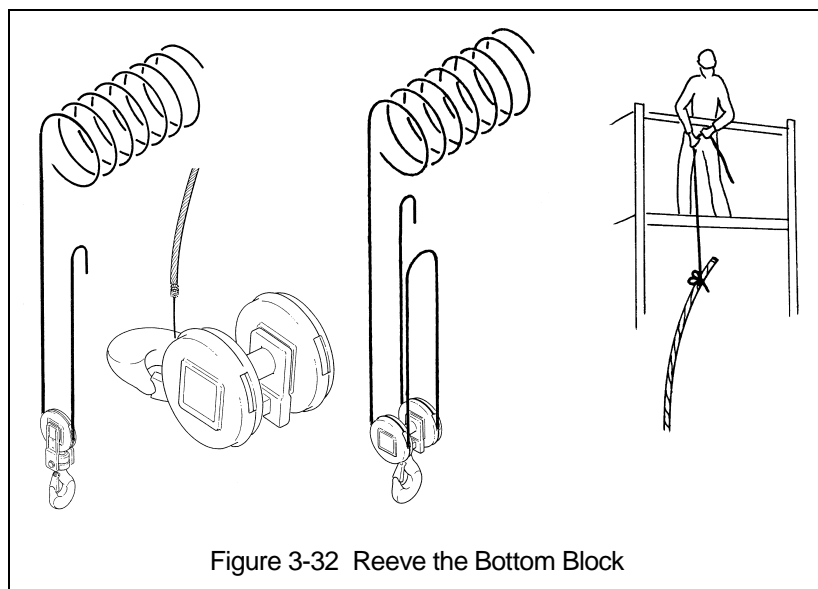
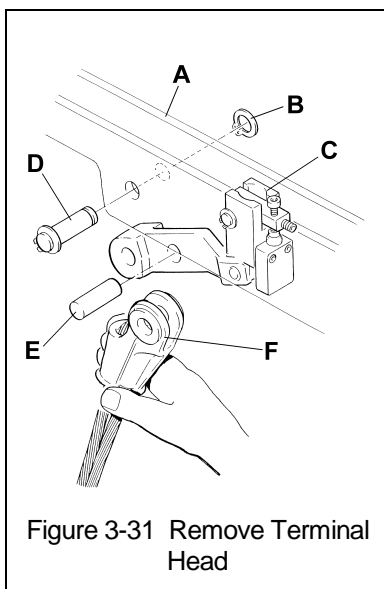

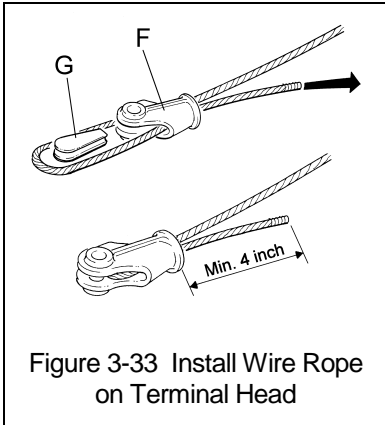

Figure 3-33 Install Wire Rope on Terminal Head

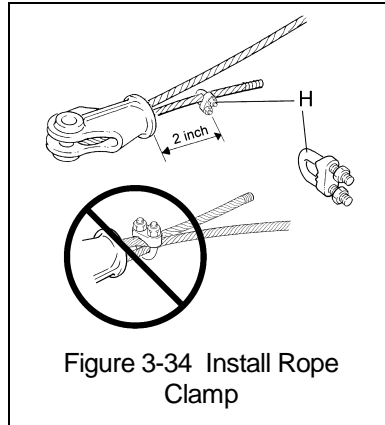

Figure 3-34 Install Rope Clamp

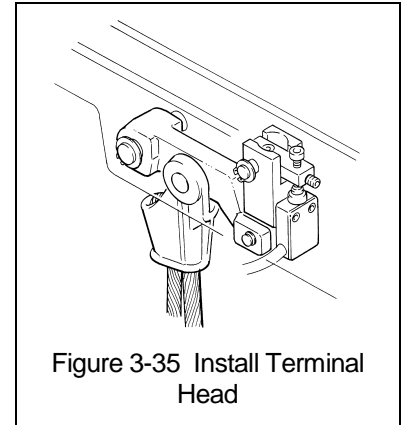
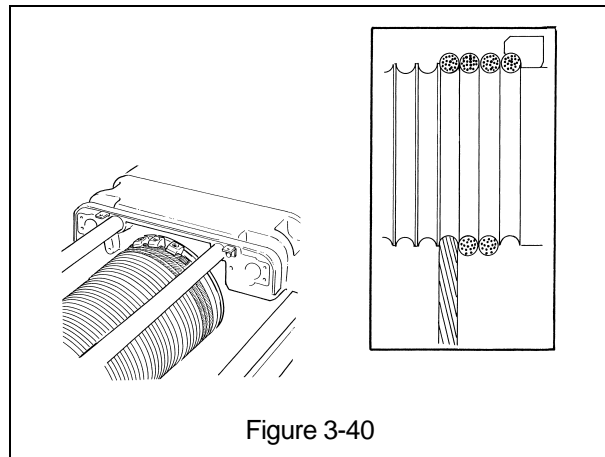
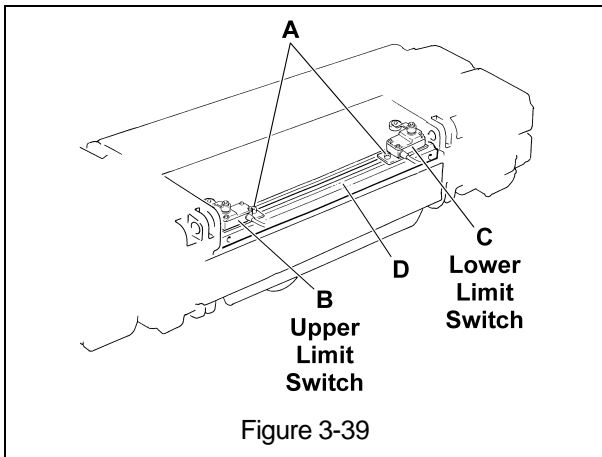
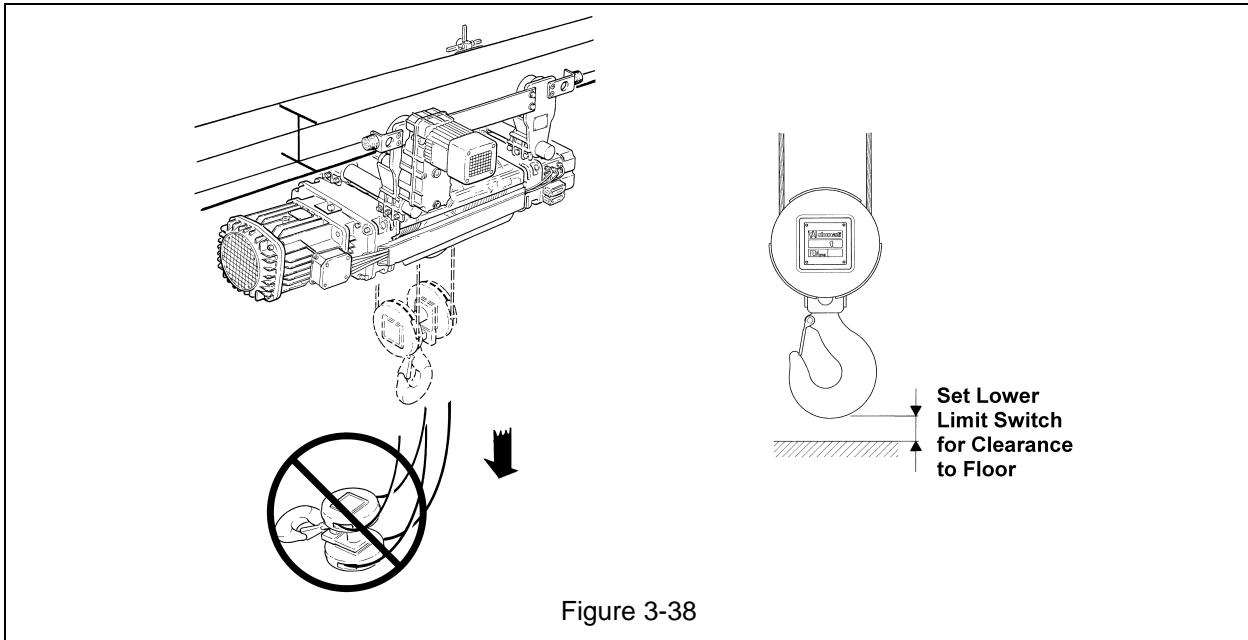
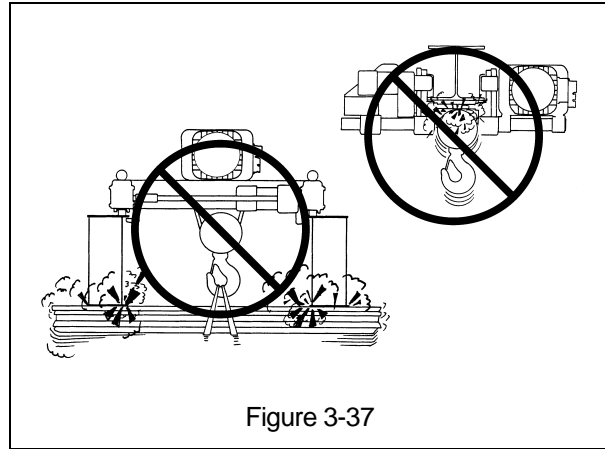
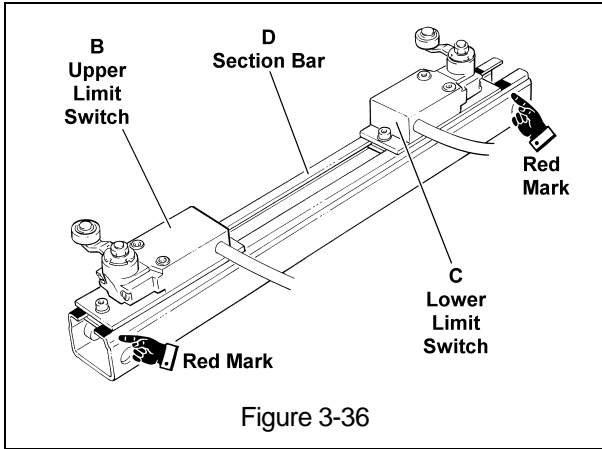

Figure 3-35 Install Terminal Head

3.6.2 Adjusting the Limit Switches:

- 1) **⚠️ WARNING** The maximum upper and lower Limit Switch (B, C) adjustments are marked in red on the Section Bar (D). NEVER adjust the limit switches past the red marks (Figure 3-36).
- 2) **⚠️ WARNING** The upper Limit Switch (B) MUST be adjusted to prevent the collision of the load and/or Bottom Block with any part of the hoist, structure or girder(s) (Figure 3-37).
- 3) **⚠️ WARNING** NEVER adjust the upper Limit Switch (B) so that the Bottom Block can raise above the position dictated by dimension “H” in Table 2-3 or “E” in Tables 2-6 and 2-9.
- 4) **⚠️ WARNING** The adjustment of the lower Limit Switch (C) MUST always ensure a minimum of 3 turns of wire rope completely wound on the drum (Figure 3-40).
- 5) The lower Limit Switch (C) MUST be adjusted so that the hook can be lowered fully for the application, WITHOUT the Hook/Bottom Block resting on the floor causing a slack condition in the wire ropes (Figure 3-38).
- 6) Lower Limit Switch (C) Setting:
 - Press the down button on the pendant and carefully lower the Hook to the position of maximum descent for the application.
 - Loosen the screws (A) so that the lower Limit Switch (C) can freely run along the Section Bar (D) then position the Switch so that it engages the striker on the rope guide. Secure the Switch in position by tightening the Screws (A) (Figure 3-39).
 - Carefully verify the correct activation of the lower Limit Switch (C) by lowering the Hook several times and readjust the Lower Limit Switch (C) as necessary.
- 7) Upper Limit Switch (B) Setting:
 - Carefully raise the Hook until it is at the uppermost position dictated by dimension “H” in Table 2-3 or “E” in Tables 2-6 and 2-9.
 - If the upper Limit Switch activates before the Hook reaches the uppermost position, measure how far the Hook still needs to travel. For 2/1 hoist multiply the distance by 2 and for 4/1 hoist multiply the distance by 4. Adjust (increase) the length of rope that extends beyond the Terminal Head by the resulting amount (Refer to Section 3.6.1).
 - Loosen the screws (A) so that the upper Limit Switch (B) can freely run along the Section Bar (D) then position the Switch so that it engages the striker on the rope guide. Secure the Switch in position by tightening the Screws (A) (Figure 3-39).
 - Carefully verify the correct activation of the upper Limit Switch (B) by raising the Hook several times and readjust the Upper Limit Switch (B) as necessary.

- 8) Check, according to the foreseen configuration, that the height of approach of the hook going up is not less than that stated in Table 2-3, 2-6 or 2-9 (dimension "H", "H1" or "E").



3.7 Pre-operational Checks and Trial Operation

- 3.7.1 Refer to the hoist's (and trolley's) Nameplate(s) and record the Product Code(s), and Serial Number(s) in the space provided on the cover of this manual.
- 3.7.2 Perform pre-operational checks for the trolley hoist:
- **⚠ WARNING** Confirm the adequacy of the rated capacity for all slings, chains, wire ropes and all other lifting attachments before use. Inspect all load suspension members for damage prior to use and replace or repair all damaged parts.
 - Ensure that trolley is properly installed on the beam, and stops for the trolley are correctly positioned and securely installed on the beam.
 - Ensure that all nuts, bolts and split pins (cotter pins) are sufficiently fastened.
 - Pull down on the Pendant and ensure that the Cord Strain Relief Cable takes the force, not the Pendant Cord.
 - **⚠ CAUTION** Check supply voltage before everyday use. If the voltage varies more than 10% of the rated value, electrical devices may not function normally.
- 3.7.3 Confirm proper operation:
- Before operating read and become familiar with Section 4 - Operation.
 - Before operating ensure that the hoist (and trolley) meets the Inspection, Testing and Maintenance requirements of ANSI/ASME B30.16.
 - Before operating ensure that nothing will interfere with the full range of the hoist's (and trolley's) operation.
- 3.7.4 Proceed with trial operation to confirm proper operation.
- Verify that the controls agree with hoist direction. Make sure that depression of the Up button lifts the Bottom Block and depression of the Down button lowers the Bottom Block. If the Bottom Block does not move in the correct direction when the push buttons are pushed, the power supply is phased incorrectly. In this case, turn off the power source or breaker switch then reverse any two of the three wires at the power source. The hook will then move in accordance with the directions of the push button.
 - Operate the trolley through it's full range of motion. Make sure the trolley runs smoothly and does not bind. Check the power supply and festoon system for proper operation
 - Perform inspections per Section 5.3, "Frequent Inspections".

4.0 Operation

4.1 Introduction

DANGER

DO **NOT** WALK UNDER A SUSPENDED LOAD

WARNING

HOIST OPERATORS SHALL BE REQUIRED TO READ THE OPERATION SECTION OF THIS MANUAL, THE WARNINGS CONTAINED IN THIS MANUAL, INSTRUCTION AND WARNING LABELS ON THE HOIST OR LIFTING SYSTEM, AND THE OPERATION SECTIONS OF ANSI/ASME B30.16 and ANSI/ASME B30.10. THE OPERATOR SHALL ALSO BE REQUIRED TO BE FAMILIAR WITH THE HOIST AND HOIST CONTROLS BEFORE BEING AUTHORIZED TO OPERATE THE HOIST OR LIFTING SYSTEM.

HOIST OPERATORS SHOULD BE TRAINED IN PROPER RIGGING PROCEDURES FOR THE ATTACHMENT OF LOADS TO THE HOIST HOOK.

HOIST OPERATORS SHOULD BE TRAINED TO BE AWARE OF POTENTIAL MALFUNCTIONS OF THE EQUIPMENT THAT REQUIRE ADJUSTMENT OR REPAIR, AND TO BE INSTRUCTED TO STOP OPERATION IF SUCH MALFUNCTIONS OCCUR, AND TO IMMEDIATELY ADVISE THEIR SUPERVISOR SO CORRECTIVE ACTION CAN BE TAKEN.

HOIST OPERATORS SHOULD HAVE NORMAL DEPTH PERCEPTION, FIELD OF VISION, REACTION TIME, MANUAL DEXTERITY, AND COORDINATION.

HOIST OPERATORS SHOULD **NOT** HAVE A HISTORY OF OR BE PRONE TO SEIZURES, LOSS OF PHYSICAL CONTROL, PHYSICAL DEFECTS, OR EMOTIONAL INSTABILITY THAT COULD RESULT IN ACTIONS OF THE OPERATOR BEING A HAZARD TO THE OPERATOR OR TO OTHERS.

HOIST OPERATORS SHOULD **NOT** OPERATE A HOIST OR LIFTING SYSTEM WHEN UNDER THE INFLUENCE OF ALCOHOL, DRUGS, OR MEDICATION.

OVERHEAD HOISTS ARE INTENDED ONLY FOR VERTICAL LIFTING SERVICE OF FREELY SUSPENDED UNGUIDED LOADS. DO **NOT** USE HOIST FOR LOADS THAT ARE NOT LIFTED VERTICALLY, LOADS THAT ARE NOT FREELY SUSPENDED, OR LOADS THAT ARE GUIDED.

NOTICE

- Read ANSI/ASME B30.16 and ANSI/ASME B30.10.
- Read the hoist manufacturer's Operating and Maintenance Instructions.
- Read all labels attached to equipment.

The operation of an overhead hoist involves more than activating the hoist's controls. Per the ANSI/ASME B30 standards, the use of an overhead hoist is subject to certain hazards that cannot be mitigated by engineered features, but only by the exercise of intelligence, care, common sense, and experience in anticipating the effects and results of activating the hoist's controls. Use this guidance in conjunction with other warnings, cautions, and notices in this manual to govern the operation and use of your overhead hoist.

4.2 Shall's and Shall Not's for Operation

WARNING

Improper operation of a hoist can create a potentially hazardous situation which, if not avoided, could result in death or serious injury, and substantial property damage. To avoid such a potentially hazardous situation **THE OPERATOR SHALL:**

- **NOT** operate a damaged, malfunctioning or unusually performing hoist.
- **NOT** operate a hoist until you have thoroughly read and understood Manufacturer's Operating and Maintenance Instructions or Manuals.
- Be familiar with operating controls, procedures, and warnings.
- **NOT** operate a hoist which has been modified without the manufacturer's approval or without certification that it is in conformity with ANSI/ASME B30 volumes.
- **NOT** lift more than rated load for the hoist.
- **NOT** use hoist with twisted, kinked, damaged, or worn wire rope.
- **NOT** use the hoist to lift, support, or transport people.
- **NOT** lift loads over people.
- **NOT** operate a hoist unless all persons are and remain clear of the supported load.
- **NOT** operate unless load is centered under hoist.
- **NOT** attempt to lengthen the load wire rope or repair damaged load wire rope.
- Protect the hoist's load wire rope from weld splatter or other damaging contaminants.
- **NOT** operate hoist when it is restricted from forming a straight line from hook to support in the direction of loading.
- **NOT** use load wire rope as a sling or wrap load wire rope around load.
- **NOT** apply the load to the tip of the hook or to the hook latch.
- **NOT** apply load unless the wire rope is properly seated in its grooves.
- **NOT** apply load if bearing prevents equal loading on all load supporting ropes.
- **NOT** operate beyond the limits of the load wire rope travel.
- **NOT** leave load supported by the hoist unattended unless specific precautions have been taken.
- **NOT** allow the load wire rope or hook to be used as an electrical or welding ground.
- **NOT** allow the load wire rope or hook to be touched by a live welding electrode.
- **NOT** remove or obscure the warnings on the hoist.
- **NOT** operate a hoist on which the safety placards or decals are missing or illegible
- **NOT** operate a hoist unless it has been securely attached to a suitable support.
- **NOT** operate a hoist unless load slings or other approved single attachments are properly sized, and seated in the hook saddle.
- **NOT** use the hoist in such a way that could result in shock or impact loads being applied to the hoist.
- Take up slack carefully - make sure load is balanced and load-holding action is secure before continuing.
- Shut down a hoist that malfunctions or performs unusually and report such malfunction.
- Make sure hoist limit switches function properly.
- Warn personnel before lifting or moving a load.
- Warn personnel of an approaching load.

⚠ CAUTION

Improper operation of a hoist can create a potentially hazardous situation which, if not avoided, could result in minor or moderate injury, or property damage. To avoid such a potentially hazardous situation **THE OPERATOR SHALL:**

- Maintain a firm footing or be otherwise secured when operating the hoist.
- Check brake function by tensioning the hoist prior to each lift operation.
- Use hook latches. Latches are to retain slings, chains, etc. under slack conditions only.
- Make sure the hook latches are closed and not supporting any parts of the load.
- Make sure the load is free to move and will clear all obstructions.
- Avoid swinging the load or hook.
- Make sure hook travel is in the same direction as shown on controls.
- Inspect the hoist regularly, replace damaged or worn parts, and keep appropriate records of maintenance.
- Use the hoist manufacturer's recommended parts when repairing the unit.
- Lubricate load wire rope per hoist manufacturer's recommendations.
- **NOT** use the hoist load limiting or warning device to measure load.
- **NOT** use limit switches as routine operating stops. They are emergency devices only.
- **NOT** allow your attention to be diverted from operating the hoist.
- **NOT** allow the hoist to be subjected to sharp contact with other hoists, structures, or objects through misuse.
- **NOT** adjust or repair the hoist unless qualified to perform such adjustments or repairs.

4.3 Hoist and Trolley Controls

- 4.3.1 Single Speed Pendant Control - When using the pendant control depress the Up button to raise the hoist's hook or the Down button to lower the hoist's hook as shown in Figure 4-1. Depress the Forward and Reverse buttons to move the trolley horizontally. To stop motion release the buttons.
- 4.3.2 Dual Speed Pendant Control – Pendant controls supplied with dual speed hoists or trolleys have two step control buttons. For low speed depress the button to the first step and for high speed depress the button fully to the second step. Use the Up button to raise the hoist's hook or the Down button to lower the hoist's hook as shown in Figure 4-1. Depress the Forward and Reverse buttons to move the trolley horizontally. To stop motion release the buttons.
- 4.3.3 Trolley with Two Button Pendant – When a motorized trolley is supplied with a two button pendant, the pendant buttons control the trolley's horizontal motion in the forward and reverse directions. Single and dual speed buttons function identical to the four button pendant described above.

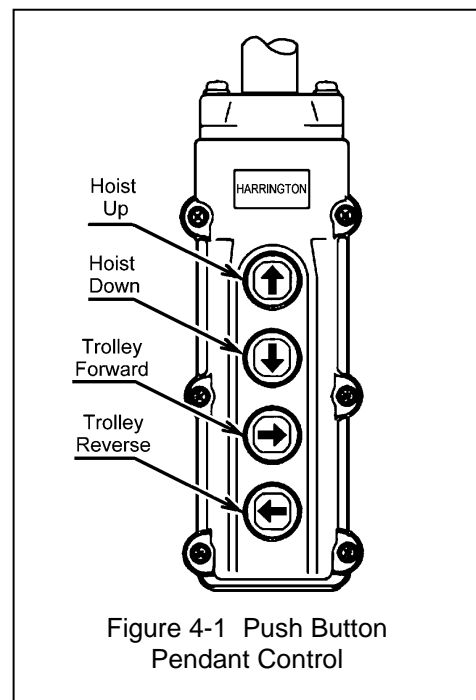

5.0 Inspection

5.1 General

- 5.1.1 The inspection procedure herein is based on ANSI/ASME B30.16. The following definitions are from ANSI/ASME B30.16 and pertain to the inspection procedure below.
- Designated Person – a person selected or assigned by the employer or employer’s representative as being competent to perform the specific duties.
 - Qualified Person – a person who, by possession of a recognized degree in an applicable field, or certificate of professional standing, or who, by extensive knowledge, training, and experience, has successfully demonstrated the ability to solve or resolve problems relating to the subject matter and work.
 - Normal Service – that distributed service, which involves operation with randomly, distributed loads within the rated load limit, or uniform loads less than 65% of rated load for not more than 25% of the time.
 - Heavy Service – that service, which involves operation within the rated, load limit which exceeds normal service.
 - Severe Service – that service which involves normal or heavy service with abnormal operating conditions.

5.2 Inspection Classification

- 5.2.1 The Initial Inspection – a designated person shall inspect prior to initial use all new, re-installed, altered, or modified hoists/trolleys to ensure compliance with the applicable provisions of this manual.
- 5.2.2 Inspection Classification – the inspection procedure for hoists/trolleys in regular service is divided into two general classifications based upon the intervals at which inspection should be performed. The intervals in turn are dependent upon the nature of the critical components of the hoists/trolleys and the degree of their exposure to wear, deterioration, or malfunction. The two general classifications are herein designated as FREQUENT and PERIODIC, with respective intervals between inspections as defined below.
- 5.2.3 FREQUENT Inspection – visual examinations by the operator or other designated personnel with intervals per the following criteria:

Service	Hoist and Trolley Interval	Rope Inspection Interval
Normal Service	Monthly	Start of Every Shift
Heavy Service	Weekly to Monthly	
Severe Service	Daily to Weekly	
Special or Infrequent Service	As recommended by a qualified person before and after each occurrence.	

5.2.4 PERIODIC Inspection – visual inspection by a designated person with intervals per the following criteria:

Table 5-2 Periodic Inspection Intervals		
Service	Hoist and Trolley Interval	Rope Inspection Interval
Normal Service	Monthly	1) At Least monthly (per OSHA), AND 2) Determined by a qualified person and based on such factors as expected rope life as determined by experience on the particular or similar installations; severity of environment; percentage of capacity lifts; frequency rates of operation; and exposure to shock loads. Inspections need not be at equal calendar intervals and should be more frequent as the rope approaches the end of its useful life. (per ANSI B30.16-2.4.1)
Heavy Service	Weekly to Monthly	
Severe Service	Daily to Weekly	
Special or Infrequent Service	As recommended by a qualified person before the first such occurrence and as directed by the qualified person for any subsequent occurrences.	

5.3 Frequent Inspection

5.3.1 Inspections should be made on a FREQUENT basis in accordance with Table 5-3, “Frequent Inspection.” Included in these FREQUENT Inspections are observations made during operation for any defects or damage that might appear between Periodic Inspections. A designated person shall evaluate and resolve the results of FREQUENT Inspections such that the hoist/trolley is maintained in safe working condition.

Table 5-3 Frequent Inspection
All functional operating mechanisms for maladjustment and unusual sounds.
Hoist and trolley in accordance with ANSI/ASME B30.16
Operation of all limit switches and associated components
Upper limit devices in accordance with ANSI/ASME B30.16
Hoist/trolley braking system for proper operation
Hooks and hook latches in accordance with ANSI/ASME B30.10
Hook latch operation
Wire rope in accordance with Section 5.7
Wire rope reeving for compliance with Section 3.6 and 6.4
Proper function of pendant controls.

5.4 Periodic Inspection

- 5.4.1 Inspections should be made on a PERIODIC basis in accordance with Table 5-4, "Periodic Inspection." A designated person shall make evaluation and resolution of the results of PERIODIC Inspections such that the hoist is maintained in safe working condition.
- 5.4.2 For inspections where load suspension parts of the hoist/trolley are disassembled, a load test per ANSI/ASME B30.16 must be performed on the hoist/trolley after it is re-assembled and prior to its return to service.

Table 5-4 Periodic Inspection
Requirements of frequent inspection.
Evidence of loose bolts, nuts, or rivets.
Evidence of worn, corroded, cracked, or distorted parts such as suspension bolts, mounting eye bolts, stirrup bolts, stiffening plate bolts, gears, pins, bearings, pins, rollers.
Evidence of worn or damaged hook block, hook, clevises, yokes, shafts, wire rope and wire rope attachments.
Evidence of damage to hook retaining nuts or collars and pins, and welds or rivets used to secure the retaining members.
Evidence of worn or damaged rope-drum, rope guide and pulleys (sheaves).
End connections of wire rope.
Evidence of damage or excessive wear of load and idler sheaves.
Evidence of excessive wear on hoist or trolley brake system parts.
Evidence of excessive wear or damage to trolley wheels, gears and guide rollers.
Evidence of damage to supporting structure or trolley, if used.
Evidence of stress cracks on trolley stirrup plate welds.
Electrical apparatus for signs of pitting or any deterioration of visible controller contacts and electrical components, such as, switches, contacts and pushbuttons.
Proper function of motion limit devices that interrupt power or cause a warning to be activated.
Proper function of load limiter device.
Evidence of damage to all cables, including festooned cables.
Function labels on pendant control stations for legibility.
Function, instruction and warning labels properly attached to the hoist/trolley and legible (see Section 1.2).
Verify proper lubrication of gears, rope drum, rope guide, rope, sheaves and all other parts requiring lubrication.

5.5 Occasionally Used Hoists and Trolleys

- 5.5.1 Hoists that are used infrequently shall be inspected as follows prior to placing in service:
- Hoist Idle More Than 1 Month, Less Than 1 Year: Inspect per FREQUENT Inspection criteria in Section 5.3.
 - Hoist Idle More Than 1 Year: Inspect per PERIODIC Inspection criteria in Section 5.4.

5.6 Inspection Records

- 5.6.1 Dated inspection reports and records should be maintained at time intervals corresponding to those that apply for the hoist's PERIODIC interval per Section 5.2.4. These records should be stored where they are available to personnel involved with the inspection, maintenance, or operation of the hoist/trolley.
- 5.6.2 A long range rope inspection program should be established and should include records of examination of ropes removed from service so a relationship can be established between visual observation and actual condition of the rope.

5.7 Inspection Methods and Criteria

- 5.7.1 This section covers the inspection of specific items. The list of items in this section is based on those listed in ANSI/ASME B30.16 for the Frequent and Periodic Inspection. In accordance with ANSI/ASME B30.16, these inspections are not intended to involve disassembly of the hoist. Rather, disassembly for further inspection would be required if frequent or periodic inspection results so indicate. Only a qualified person trained in the disassembly and re-assembly of the hoist or trolley should perform such disassembly and further inspection.

Table 5-5 Hoist (and Trolley) Inspection Methods and Criteria

Item	Method	Criteria	Action
Functional operating mechanisms.	Visual, Auditory	Mechanisms should be properly adjusted and should not produce unusual sounds when operated.	Repair or replace as required.
Limit Switch	Function	Proper operation. Actuation of limit switch should stop hoist.	Repair or replace as required.
Hoist Braking System Operation	Function	Braking distance with rated capacity should not exceed the maximum braking distances listed in Table 5-8 .	Adjust or replace as required (see Section 6.2).
Hook - Surface Condition	Visual	Should be free of significant rust, weld splatter, deep nicks, or gouges.	Replace.
Hook - Fretting wear	Measure	The "u" and "t" dimensions should not be less than discard value listed in Table 5-6	Replace.
Hook - Stretch	Measure	The "g1" dimension should not be greater than 1.1 times that measured and recorded at the time of purchase (See Section 3.7). If recorded "g1" values are not available for hooks when new, use nominal "g1" values from Table 5-6 .	Replace.
Hook - Bent Shank or Neck	Visual	Shank and neck portions of hook should be free of deformations.	Replace.
Hook Block Assembly	Visual	Should be free of significant rust, weld splatter, nicks, gouges. Holes should not be elongated, fasteners should not be loose, and there should be no gap between mating parts.	Tighten or replace as required.
Hook Block - Swivel Bearing	Visual, Function	Bearing parts and surfaces should not show significant wear, and should be free of dirt, grime and deformations. Hook should rotate freely with no roughness.	Clean/lubricate, or replace as required.

Table 5-5 Hoist (and Trolley) Inspection Methods and Criteria (continued)

Item	Method	Criteria	Action
Hook Block - Sheave(s) and Shaft	Visual, Function	Sheave(s) should be free of significant wear. Sheave surfaces should be free of nicks, gouges, dirt and grime. Bearing parts and surfaces of Sheave and Shaft should not show significant wear. Sheave should rotate freely with no roughness or significant free play.	Clean/lubricate, or replace as required.
Hook - Hook Latches	Visual, Function	Latch should not be deformed. Attachment of latch to hook should not be loose. Latch spring should not be missing and should not be weak. Latch movement should not be stiff - when depressed and released latch should snap smartly to its closed position.	Replace.
Hoist - Housing and Mechanical Components	Visual, Auditory, Vibration, Function	Hoist components including load blocks, suspension housing, wire rope attachments, clevises, yokes, suspension bolts, shafts, gears, bearings, pins and rollers should be free of cracks, distortion, significant wear and corrosion. Evidence of same can be detected visually or via detection of unusual sounds or vibration during operation.	Replace
Trolley - Housing and Mechanical Components	Visual, Auditory, Vibration, Function	Trolley components including load bars, trolley wheels, trolley wheel axles, eye bolts, hex shafts, gears, bearings, pins, rollers, and bumpers should be free of cracks, distortion, significant wear, and corrosion. Evidence of same can be detected visually or via detection of unusual sounds or vibration during operation.	Replace.
Bolts, Nuts and Rivets	Visual	Bolts, nuts and rivets should not be loose.	Tighten or replace as required.
Wire Rope Wedge	Visual	The fixing (anchorage with wedge) must be replaced if it shows deformation, wear, cuts, or necking.	Replace
Wire Rope Drum	Visual, Function	Entire surface of the drum should be coated with lubricant and should be free of dirt and grime. Rope should fit in drum grooves.	Clean/lubricate (see Section 6.1).
Wire Rope Guide	Visual, Function	Rope Guide should be free of significant wear, cracks, nicks, gouges, dirt and grime. Rope Guide should take up rope play and move with the rope on the drum during rope unwinding and winding.	Replace
Wire Rope - Reeving	Visual	The wire rope should be reeved properly through Hook Block Sheave (and Crossbar Sheave for 4/1 hoist) - refer to Section 3.6 . Wire rope should be installed properly - refer to Section 6.4 .	Reeve/Install properly.

Table 5-5 Hoist (and Trolley) Inspection Methods and Criteria (continued)

Item	Method	Criteria	Action
<p>⚠️ WARNING The full length of the Wire Rope must be inspected for rope diameter, Broken strands or wires, and condition. Special care should be taken when inspecting sections of rapid deterioration, such as the following:</p> <ul style="list-style-type: none"> ▪ sections in contact with saddles, equalizer sheaves, or other sheaves where the rope travel is limited; ▪ sections of the rope at or near terminal ends where corroded or broken wires may protrude; ▪ sections subject to reverse bends; ▪ sections of rope which are normally hidden during visual inspection, such as parts passing over sheaves. <p>Any condition that could degrade the strength and performance of the wire rope must be reported to a qualified person for evaluation and disposition.</p>			
Wire Rope Diameter	Measure, Visual	Any reduction in the diameter of the wire rope must not be reduced due to corrosion, wear or core collapse more than the discard value in Table 5-7 . The outer wires should not be worn more than 1/3 of their original diameter.	Replace. Inspect drum and all sheaves.
Wire Rope – Broken Wires or Strands	Visual	<p>The wire rope should be inspected for broken wires or strands, paying close attention to end connection and sections that frequently pass over sheaves. The rope must NOT have:</p> <ul style="list-style-type: none"> ▪ More than the Maximum number of broken wires listed in Table 5-7. ▪ More than 4 broken wires in 1 strand in one lay (one full revolution of a strand around the rope). ▪ Any broken strands. 	Replace
Wire Rope – Condition	Visual	<ul style="list-style-type: none"> ▪ Any wire rope deformation with permanent bends, flattening, unraveling, birdcaging, etc. ▪ General corrosion. ▪ Rope core exposure. ▪ One or more loose or protruding strands or wires from rope. ▪ Severely corroded or broken wires at end connections. ▪ Severely corroded, cracked, bent, worn or improperly applied end connections ▪ Any evidence of heat damage of any kind. (Wire rope exhibits any heat discoloration or localized loss of lubrication). 	Replace
Wire Rope - Lubrication	Visual	The wire rope must be maintained in a clean and well lubricated condition.	Clean/lubricate (see Section 6.1).
Trolley Side Plates	Visual	Must be free of significant deformation	Replace
Trolley Wheel – Condition	Visual	Trolley Wheel should be free of significant wear, cracks, nicks and gouges.	Replace.

Table 5-5 Hoist (and Trolley) Inspection Methods and Criteria (continued)			
Item	Method	Criteria	Action
Trolley Wheel - Tread	Visual, Measure	Diameter of the tread surface should not be less than 5% of its original diameter as new.	Replace.
Trolley Wheel - Gear	Visual	Teeth should not be cracked, damaged, or excessively worn.	Replace.
Load Bar	Visual, Measure	Load Bar should be free of significant wear, cracks, nicks and gouges. Load Bar should not be bent.	Replace.
Trolley Motor Brake	Visual	Braking action should not be overly abrupt and should not allow excessive drift.	Adjust, Repair or Replace as required.
Contactors Contacts	Visual	Contacts should be free of significant pitting or deterioration.	Replace.
Sheaves	Visual	Sheave should be free of significant wear.	Replace.
Pendant - Switches	Function	Depressing and releasing push buttons should make and break contacts in switch contact block and result in corresponding electrical continuity or open circuit. Push buttons should be interlocked either mechanically or electrically to prevent simultaneous energizing of circuits for opposing motions (e.g. up and down, forward and reverse).	Repair or replace as necessary.
Pendant - Housing	Visual	Pendant housing should be free of cracks and mating surfaces of parts should seal without gaps.	Replace
Pendant - Wiring	Visual	Wire connections to switches in pendant should not be loose or damaged.	Tighten or repair
Pendant and Power Cords	Visual, Electrical Continuity	Surface of cord should be free from nicks, gouges, and abrasions. Each conductor in cord should have 100% electrical continuity even when cord is flexed back-and-forth. Pendant Cord Strain Relief Cable should absorb the entire load associated with forces applied to the pendant.	Replace
Pendant - Labels	Visual	Labels denoting functions should be legible.	Replace
Warning Labels	Visual	Warning Labels should be affixed to the hoist (see Section 1.2) and they should be legible.	Replace
Hoist Capacity Label	Visual	The label that indicates the capacity of the hoist should be legible and securely attached to the hoist.	Replace

Table 5-6 Bottom Hook Dimensions

g1 Measured When New:

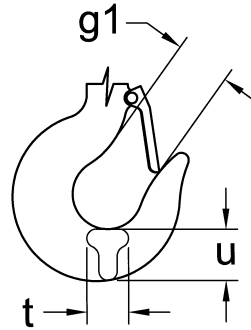

Hook Identifier (10th Character of the Hoist Product Code)	Nominal "g1" Dimension* inch (mm)	"u" Dimension inch (mm)		"t" Dimension inch (mm)	
		Standard	Discard	Standard	Discard
A or B (2 Falls)	1.50 (38)	1.46 (37)	1.39 (35.2)	1.14 (29)	1.08 (27.6)
C or D (4 Falls)	1.77 (45)	1.89 (48)	1.80 (45.6)	1.50 (38)	1.42 (36.1)
E or F (2 Falls)	1.77 (45)	1.89 (48)	1.80 (45.6)	1.50 (38)	1.42 (36.1)
G or H (4 Falls)	1.97 (50)	2.28 (58)	2.17 (55.1)	1.77 (45)	1.68 (42.8)
J or K (2 Falls)	1.97 (50)	2.28 (58)	2.17 (55.1)	1.77 (45)	1.68 (42.8)
L or M (4 Falls)	2.48 (63)	2.95 (75)	2.81 (71.3)	2.36 (60)	2.24 (57)
N or P (2 Falls)	2.48 (63)	2.95 (75)	2.81 (71.3)	2.36 (60)	2.24 (57)
Q or R (4 Falls)	3.54 (90)	4.17 (106)	3.96 (100.7)	3.35 (85)	3.18 (80.8)

* These values are nominal since the dimension is not controlled to a tolerance. The "g1" dimension should be measured when the hook is new - this becomes a reference measurement. Subsequent measurements are compared to this reference to make determinations about hook deformation/stretch. See Section 5.7, "Hooks - Stretch".

Table 5-7 Wire Rope Wear Dimensions

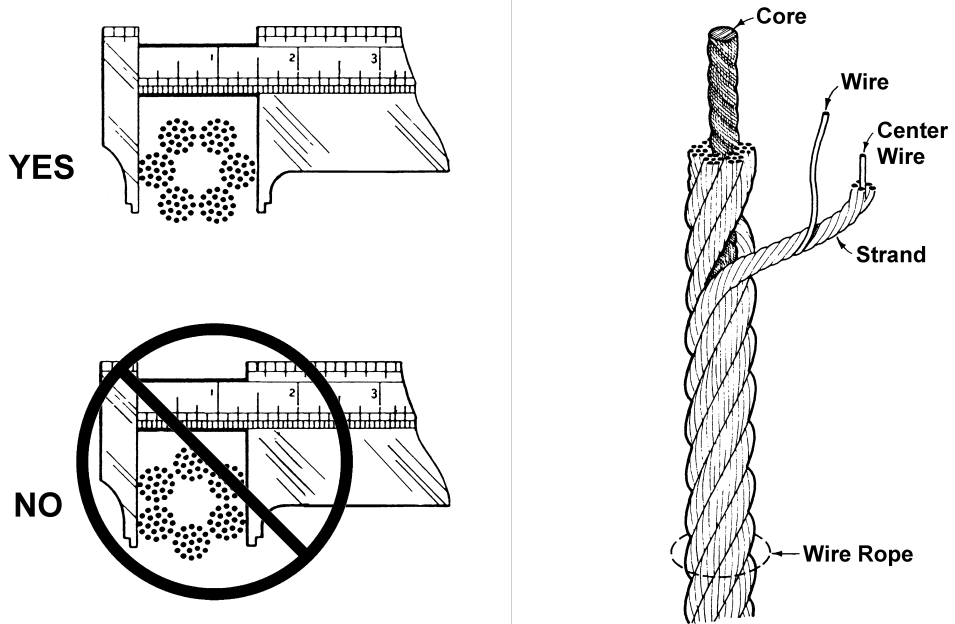

Hoist Size	Rope Diameter			Maximum Allowable Number of Broken Wires						
	Standard (mm)	Discard		Rope Construction	Rope (mm-spec.)	For 6xDia. Length		For 30xDia. Length		
		(mm)	(in)			No. Broken Wires	Length (in)	No. Broken Wires	Length (in)	
1	7	6.6	0.26	Normal	7-B	3	1.7	6	8.3	
					7-M	3	1.7	6	8.3	
					7-A	3	1.7	6	8.3	
				Anti-revolving	7-B	2	1.7	4	8.3	
					7-A	2	1.7	4	8.3	
2	8	7.6	0.30	Normal	8-M	6	1.9	12	9.4	
					8-A	10	1.9	19	9.4	
				Anti-revolving	8-M	2	1.9	4	9.4	
					8-A	2	1.9	4	9.4	
	9	8.4	0.33	Normal	9-B	3	2.1	6	10.6	
					9-M	3	2.1	6	10.6	
					9-A	3	2.1	6	10.6	
				Anti-revolving	9-M	2	2.1	4	10.6	
					9-A	9-M	2	2.1	4	10.6
						9-A	2	2.1	4	10.6
3	12	11.2	0.44	Normal	12-M	14	2.8	29	14.2	
					12-A	13	2.8	26	14.2	
	13	12.2	0.48	Anti-revolving	13-A	2	3.1	4	15.4	
					Normal	13-B	5	3.1	10	15.4
				13-M		7	3.1	14	15.4	
				13-A		3	3.1	6	15.4	
				Anti-revolving		13-B	2	3.1	4	15.4
					13-A	2	3.1	4	15.4	

Hoist Size	Rope Diameter			Maximum Allowable Number of Broken Wires					
	Standard (mm)	Discard		Rope Construction	Rope (mm-spec.)	For 6xDia. Length		For 30xDia. Length	
		(mm)	(in)			No. Broken Wires	Length (in)	No. Broken Wires	Length (in)
4	15	14.0	0.55	Normal	15-M	14	3.5	29	17.7
					15-A	14	3.5	29	17.7
				Anti-revolving	15-A	2	3.5	4	17.7
	16	14.9	0.59	Normal	16-B	7	3.8	14	18.9
					16-M	7	3.8	14	18.9
					16-A	7	3.8	14	18.9
				Anti-revolving	16-B	2	3.8	4	18.9
					16-M	2	3.8	4	18.9
					16-A	2	3.8	4	18.9

No. of Falls	Speed	HOIST SIZE* ⇒	1	2	3	4
2 Fall	48 ft/min	Maximum Limit Before Adjustment	4.72	5.91	7.10	8.27
		Best Value Following Adjustment	1.57	1.97	2.36	2.76
	32 ft/min	Maximum Limit Before Adjustment	3.54	4.72	5.91	7.09
		Best Value Following Adjustment	1.18	1.57	1.97	2.36
4 Fall	24 ft/min	Maximum Limit Before Adjustment	2.36	2.95	3.54	4.13
		Best Value Following Adjustment	0.79	0.98	1.18	1.38
	16 ft/min	Maximum Limit Before Adjustment	1.77	2.36	2.95	3.54
		Best Value Following Adjustment	0.59	0.79	0.98	1.18

*To determine the hoist size, refer to Section 2.1.2.

6.0 Maintenance and Handling

6.1 Lubrication

6.1.1 Wire Rope:

- For proper performance the Wire Rope must be maintained in a clean and well lubricated condition.
- The rope should be lubricated every 3 months (more frequently for heavier usage or severe conditions).
- To lubricate the rope, first remove any dirt, grime, moisture or other accumulations of contaminants. Then coat the Wire Rope with Agip 360 EP/F oil or equivalent. Ensure that the lubricant is applied to the entire surface of the rope over its entire length.

6.1.2 Wire Rope Drum, Hook Block and Sheaves:

- The drum and hook block should be lubricated every 3 months (more frequently for heavier usage or severe conditions).
- Lubricate the Drum, Hook Block and Sheaves with Agip Blasias 320 oil or Agip Blasias GR MU3 grease.

6.1.3 Trolley Wheels and Gears:

- The Trolley Wheels and Gears should be lubricated every 3 months (more frequently for heavier usage or severe conditions).
- Lubricate the Trolley Wheels and Gears with Agip Blasias GR MU3 grease

6.1.4 Hoist and Trolley Gearboxes – The hoist and trolley gearboxes are lubricated for life and should not need any lubricant replacement.

6.2 Hoist Motor Brake

6.2.1 To keep your hoist working in optimum condition and prevent possible down time, it is recommended to check your motor brake and adjustment at regular intervals.

6.2.2 Motor brake adjustment is as follows:

- 1) **⚠ DANGER** Before proceeding, ensure that the electrical supply for the hoist or trolley has been de-energized (disconnected). Lock out and tag out in accordance with ANSI Z244.1 “Personnel Protection -Lockout/Tagout of Energy Sources”.
- 2) Adjustment and inspection of the motor brake requires removal of the motor brake cover from the hoist.
- 3) To remove the cover (A), remove the 4 Cover Screws (B), then remove the Cover (see Figure 6-1).
- 4) Remove the 3 screws (E) from the Blocking Ring (D) of the brake lock (see Figure 6-2).
- 5) To adjust the brake, rotate the Blocking Ring (D) counterclockwise to increase brake pressure, clockwise for less pressure. One complete revolution is equal to 1mm of axial movement. Moving the ring may require using a screwdriver in the notch of the Blocking Ring (D) (see Figure 6-3)

6.2.3 Motor Brake Re-assembly - After the brake is properly adjusted and inspected, reassemble the parts in reverse order of removal.

6.2.4 Motor Brake Check

- 1) Ensure that the motor runs freely and quietly.
- 2) Ensure that the brake is not overheating.

- 3) Check that the brake adjustment has been performed correctly. Complete the brake test, first with no load and then with a nominal load (see Table 5-8).
- 4) Readjust the brake as necessary.
- 5) It is recommended that the brake be replaced after 3 adjustments.

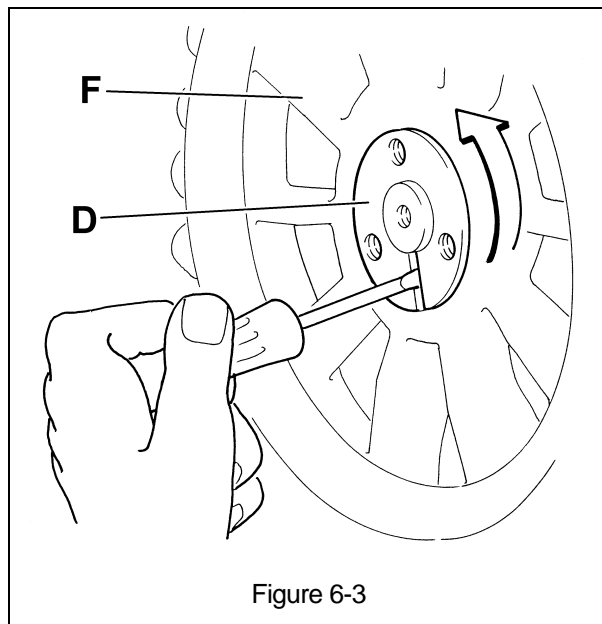
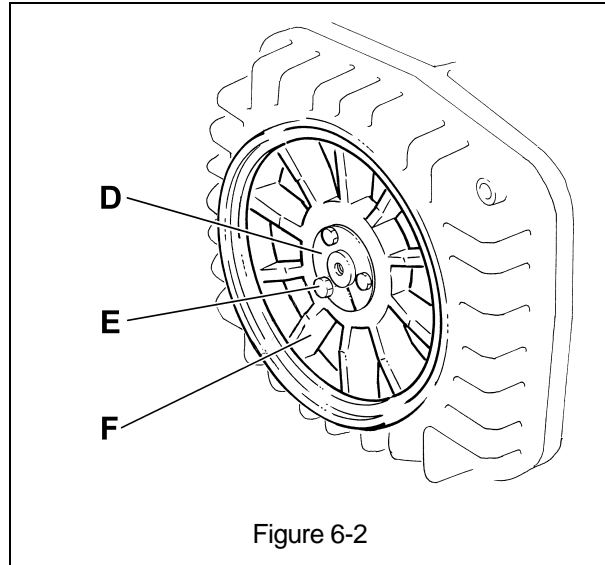
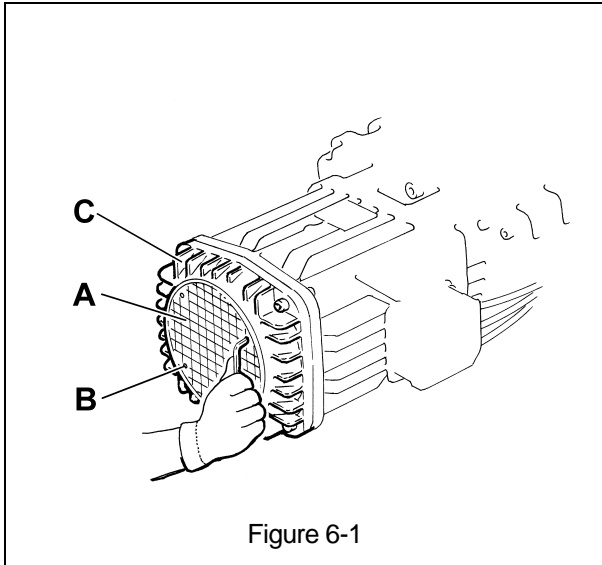

6.3 Trolley Motor Brake

6.3.1 The Trolley Brake adjustment can be accomplished 2 ways:

- External Method – External adjustment in the case of moderate wear or when changing the brake pre-sets.
- Internal Method – Internal adjustment is required after the External method does not provide enough braking. This usually occurs when brake wear exceeds 1mm.

6.3.2 To adjust the trolley motor brake for either the external or internal method, it is necessary to perform the following steps:

- 1) **⚠ DANGER** Before proceeding, ensure that the electrical supply for the hoist or trolley has been de-energized (disconnected). Lock out and tag out in accordance with ANSI Z244.1 “Personnel Protection -Lockout/Tagout of Energy Sources”.
- 2) Remove the trolley Motor Cover (A) by unscrewing the 4 Screws (B) (see Figure 6-4).

6.3.3 External Method – The external method allows the braking force to be increased or decreased as required without disassembling the brake.

- 1) Remove the Lock-Nut (C), Fan (D), external Thickness Washers (E), Snap Ring (F), Pressure Washer (G) and Spring (H) (see Figure 6-5 and 6-6).
- 2) To INCREASE braking, add some or all of the external Thickness Washers (E) to the Thickness Washers (E) adjacent to the motor as necessary to obtain the required braking force (see Figure 6-6).
- 3) To DECREASE braking, remove a quantity of the internal Thickness Washers (E) adjacent to the motor and add them to the external Thickness Washers (E) during re-assembly (between the fan (D) and the snap ring (F) as required to obtain the required decrease in braking force (see Figure 6-6).
- 4) Reinstall the Spring (H), Pressure Washer (G), Snap Ring (F), Thickness Washers (E), Fan (D) and Lock-Nut (C).
- 5) Reinstall the trolley Motor Cover (A) using the 4 Screws (B).
- 6) Perform brake tests and repeat the above steps as necessary to obtain the required trolley braking.

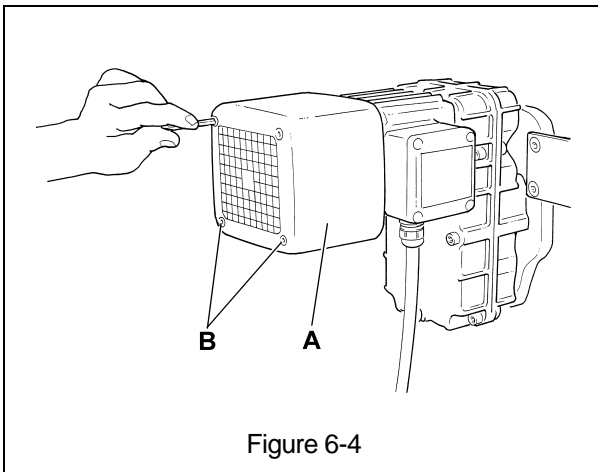

Figure 6-4

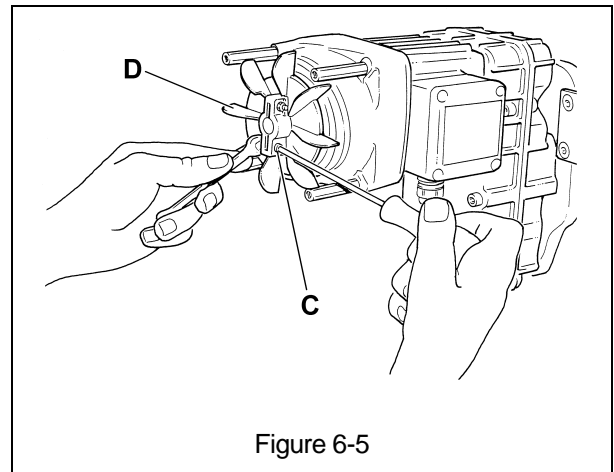

Figure 6-5

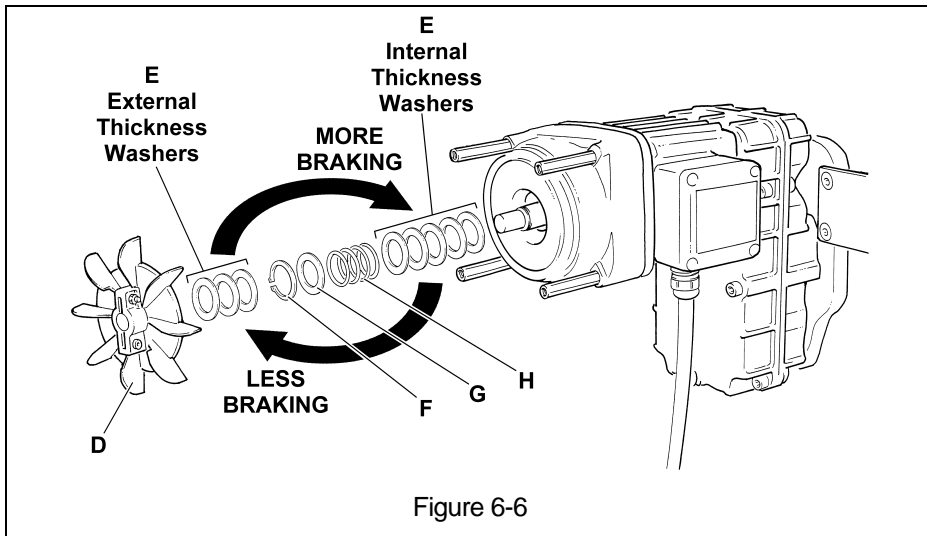

Figure 6-6

6.3.4 Internal Method – The internal method allows the braking to be increased as required.

- 1) Remove the Lock-Nut (C), Fan (D), Snap Ring (F), Pressure Washer (G), Spring (H) and all Thickness Washers (E) (see Figure 6-5 and 6-6).
- 2) Unscrew and remove the Hexagonal Spacers (J) and Nuts then remove the Motor Cover (P). Carefully, so as not to damage the rotor and/or the winding, slide the Rotor (N) with Brake Block (K) out of the motor completely (see Figure 6-7).
- 3) Remove the Snap Ring (L), external Drum Spacers (M), Brake Block (K), without removing the internal Drum Spacers (M) nearest the rotor. Transfer the necessary quantity of external Drum Spacers (M) to the Rotor (N) side of the brake block (K) to provide more braking (see Figure 6-8).
- 4) Reinstall the brake block (K), Drum Spacers (M), Snap Ring (L) and reinsert the rotor in the motor. Reinstall the Motor Cover (P), Hexagonal Spacers (J) and Nuts (see Figure 6-9).
- 5) Confirm acceptable trolley braking distance. Perform the steps of Section 6.3.3 External Trolley Brake Adjustment for further adjustment if necessary.

6.3.5 If the adjustment has been performed several times and the required braking cannot be obtained, it is necessary to replace the motor cover (P), ordering ONLY original spare parts.

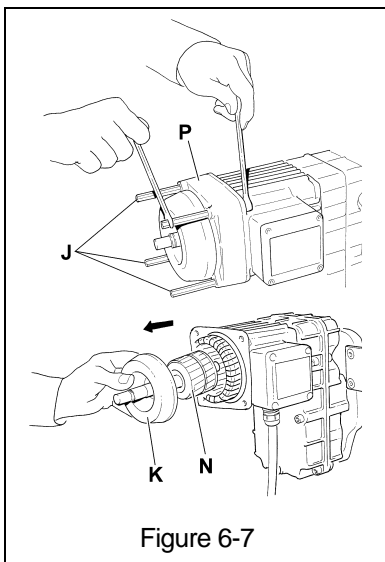

Figure 6-7

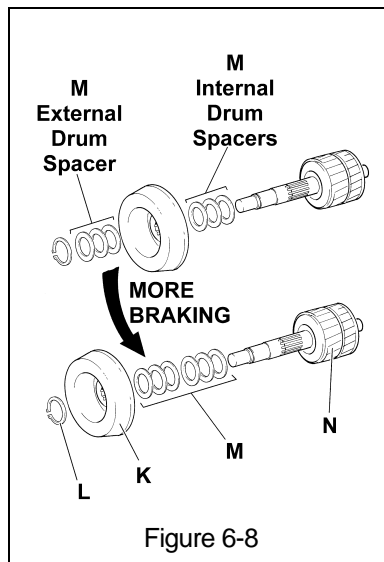

Figure 6-8

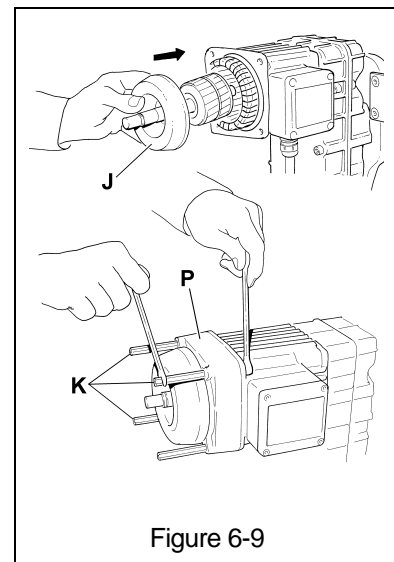

Figure 6-9

6.4 Wire Rope

6.4.1 Lubrication and Cleaning – Refer to Section 6-1.

6.4.2 **⚠ WARNING** Be certain that the replacement wire rope is obtained from Harrington Hoists, Inc. and is the correct wire rope for the hoist. If the wire rope is being replaced due to damage or wear out, destroy the old rope to prevent its reuse.

6.4.3 Wire Rope Removal

- 1) **⚠ CAUTION** The hoist must be properly powered and operational in order to perform the following procedures.
- 2) **⚠ CAUTION** It is strongly advised to use the Wire Rope Guide Tool (part number, DMFOA0000) during rope replacement. The Wire Rope Guide Tool is available from Harrington Hoists, Inc. (see Figure 6-10).
- 3) **⚠ CAUTION** When replacing Wire Rope, check for wear on mating parts, i.e. Drum, Sheaves, Hook Block Sheaves and replace if necessary.
- 4) Lower the Hook Block to the lowest possible position without touching the floor or ground.
- 5) Remove the Anchorage Assembly (F) by removing Pin (D) from the Terminal Head Cross Bar (A) to free the lever of the Load Limiter (C) (see Figure 6-11).
- 6) Rotate the lever downwards until the Anchorage Pin (E) can be removed allowing the Anchorage (F) to be removed for disassembly.
- 7) Remove the Wire Rope Clamp (G) and loosen the Wire Rope until the Terminal Wedge (H) can be removed from the Anchorage Assembly (F) (see Figure 6-12).
- 8) Remove (unreeve) the Wire Rope from the Bottom Block and all Sheaves.

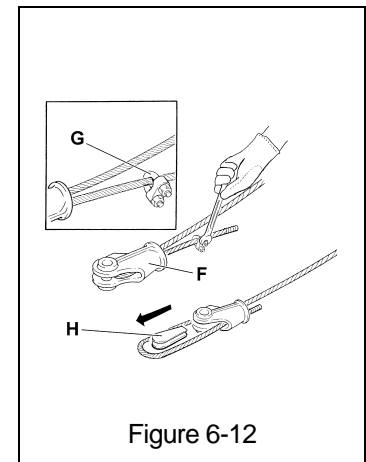
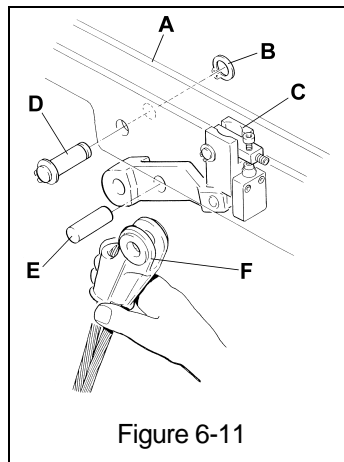
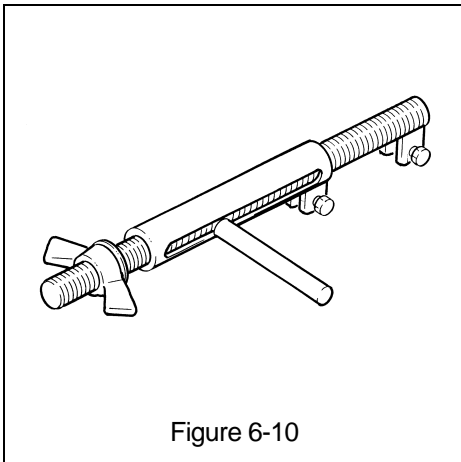

- 9) Remove the Dust Cover (K) by unscrewing the Dust Cover Screws (J) (see Figure 6-13).
- 10) Gain access to the Rope Guide and associated components.
 - **For OTHER THAN 4/1 Ultra-Low Headroom Version:** Remove, by lifting out, the Anchorage Cross Head (A) (includes the pulley assembly for 4/1 part/reeved hoists) after removing the Safety Screws (L). Take care not to disconnect or damage the overload device (C) (see Figure 6-14). Secure the Anchorage Cross Head (A) to the Bottom Bracket (M) (See Figure 6-15).
 - **For 4/1 Ultra-Low Headroom Version:** Remove the Limit Switch Assembly (C1) removing the Screws (D1). Do not disconnect or change the setting of the Limit Switches (see Figure 6-16).
- 11) Remove the Screws (R) and the Limit Switch Actuators (N) from the Rope Guide Ring Halves (P) and (Q) (see Figure 6-17).
- 12) Remove the Wire Clamping Spring (T) using the Wire Rope Guide Clamping Tool (S) and pliers to remove the Clip (U) (see Figure 6-18).

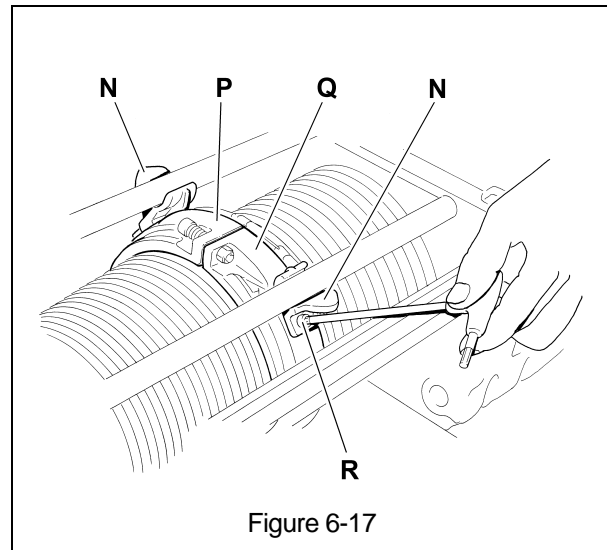
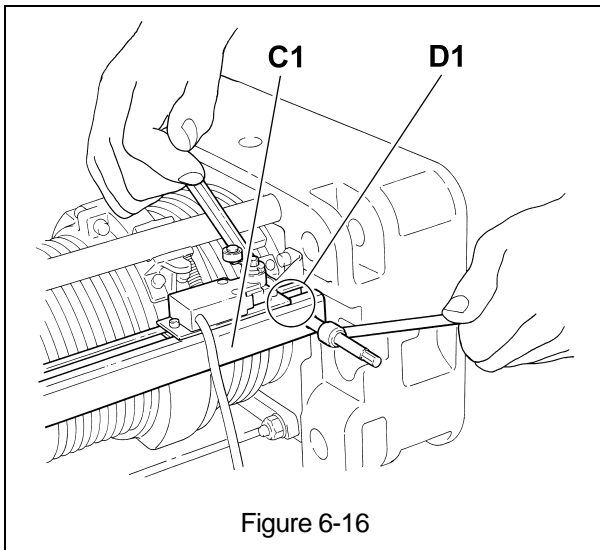
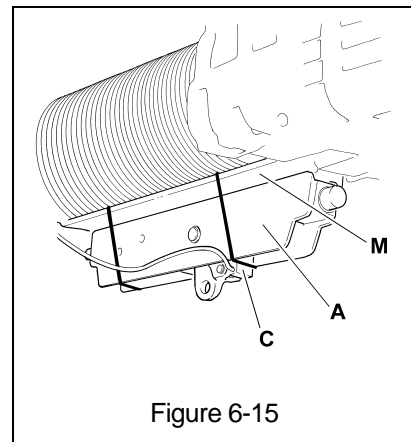
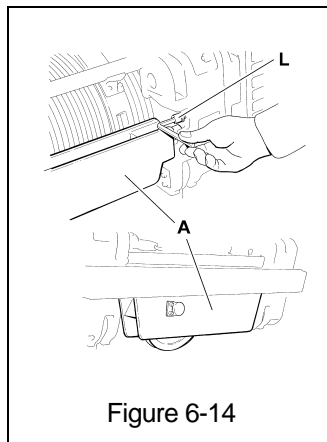
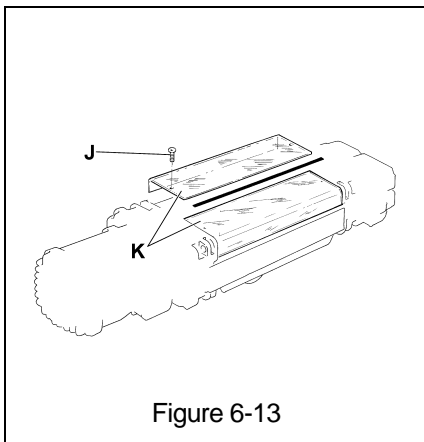

13) Unscrew the Nuts (X) remove the Screws (V) and the Springs (W) from the Rope Guide Ring Halves (P and Q), then remove the Ring Half (Q) (see Figure 6-19).

14) Loosen the Screws (A1) of the Wire Rope Clamps (B1) and take out the Wire Rope and Ring Half (P) (see Figure 6-20). For 4/1 Ultra-Low headroom versions it is necessary to rotate the Ring Half (P) over the top of the drum to remove it from the hoist (see Figure 6-21).

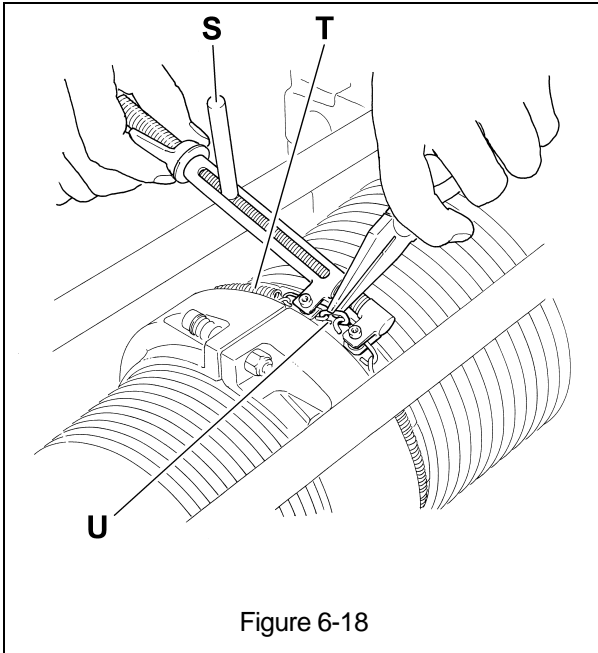

Figure 6-18

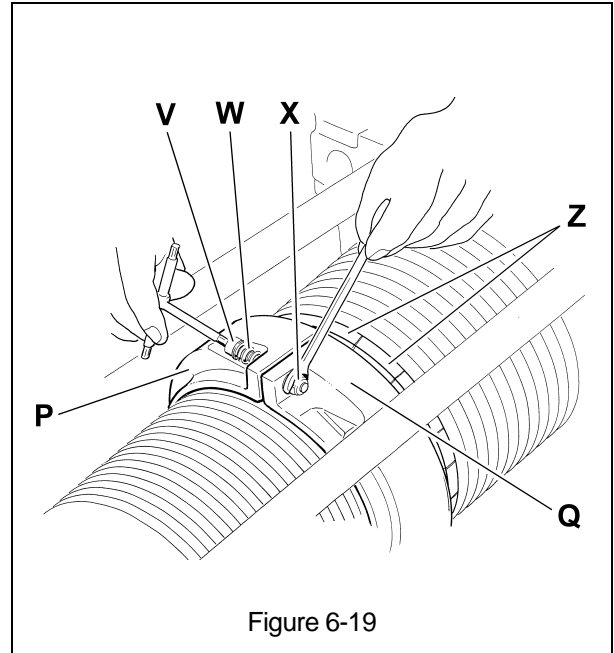

Figure 6-19

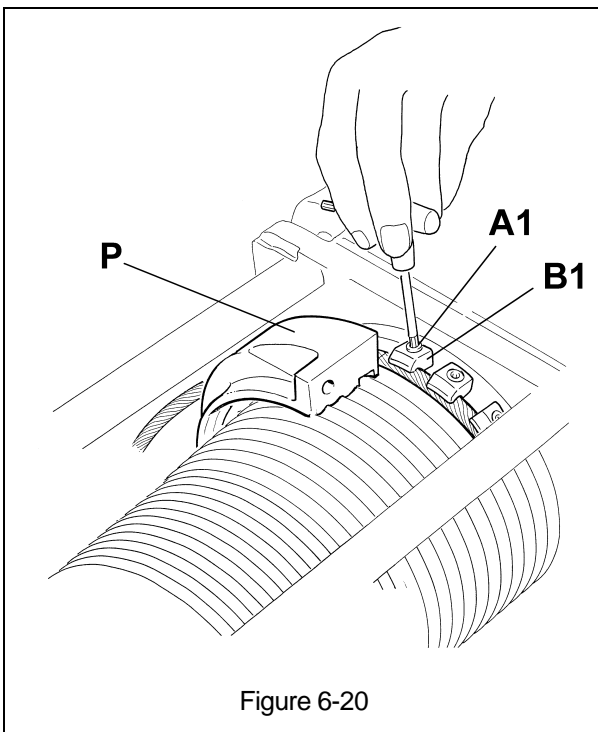

Figure 6-20

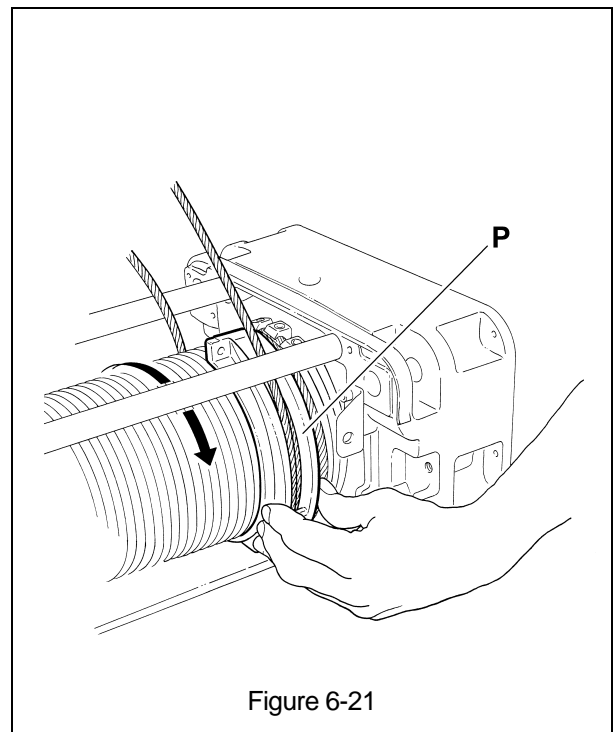

Figure 6-21

6.4.4 Wire Rope Installation

- 1) **⚠ CAUTION** The hoist must be properly powered and operational in order to perform the following procedures.
- 2) **⚠ CAUTION** When replacing Wire Rope, check for wear on mating parts, i.e. Drum, Sheaves, Hook Block Sheaves and replace if necessary.
- 3) **⚠ WARNING** ALWAYS unwind the roll of the new Wire Rope without kinks or bends (see Figure 6-22).
- 4) Examine the Wire Rope Guide Ring Halves (P) and (Q) and the Drum after cleaning/degreasing thoroughly.
- 5) Verify proper fit of the Wire Rope Guide Ring Halves (P) and (Q) with the Drum, matching up the respective grooves and check that there is no excessive clearance. Check for pointed or sharp crests and heavy wear and tear. Where necessary assess the need for replacing the wire rope guides and the Drum.
- 6) Securing the Wire Rope to the Drum:
 - **For OTHER THAN 4/1 Ultra-Low Headroom Version:** Insert the new Wire Rope in the “slit” of the Rope Guide Ring Half (P) and secure the end of the Wire Rope with three (3) Wire Rope Clamps (B1). Torque the Screws (A1) to the value shown in Table 6-1 for your hoist (see Figure 6-23).
 - **For 4/1 Ultra-Low Headroom Version:** Pass the end of the new Wire Rope up between the beam and the Drum, directly over the Drum, and insert it through the “slit” of the Rope Guide Ring Half (P). Rotate the Rope Guide Ring Half (P) directly over the Drum into position between the beam and Drum (see Figure 6-24). Secure the end of the Wire Rope to the Drum with 3 Wire Rope Clamps (B1). Torque the Screws (A1) to the value shown in Table 6-1 for your hoist (see Figure 6-23).

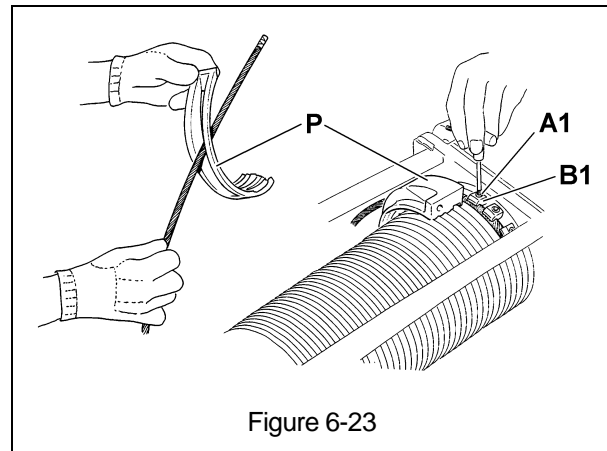
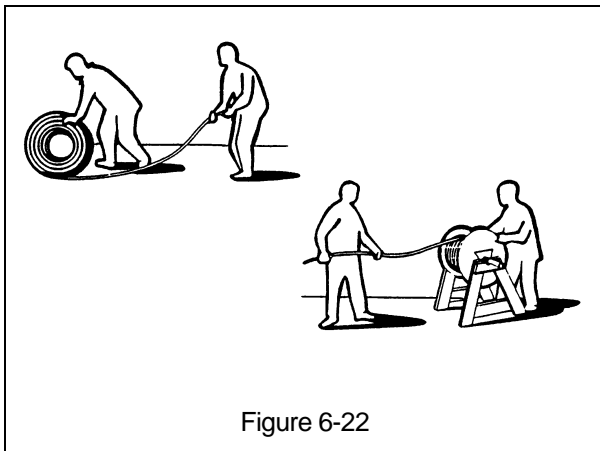
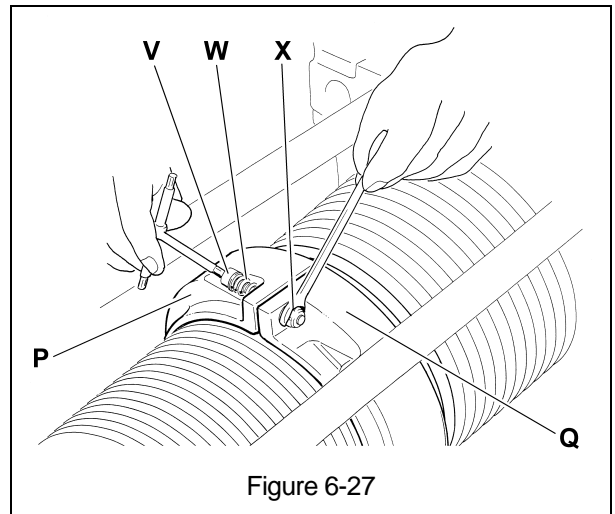
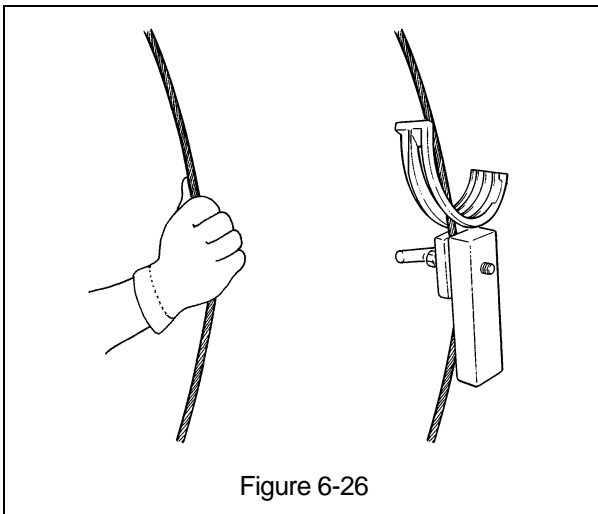
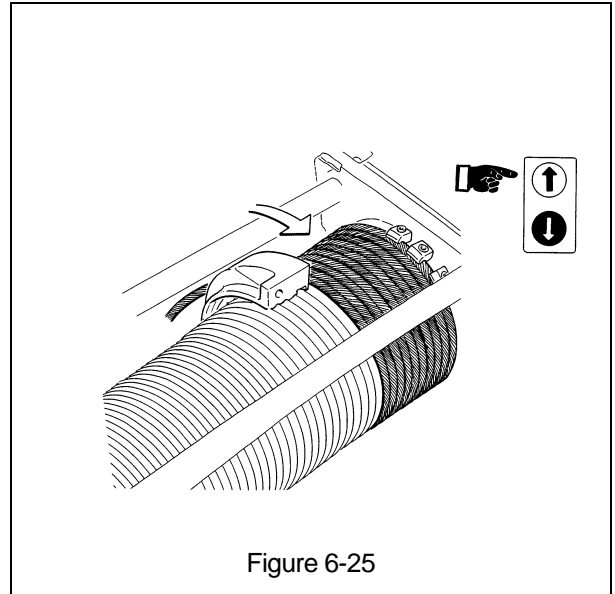
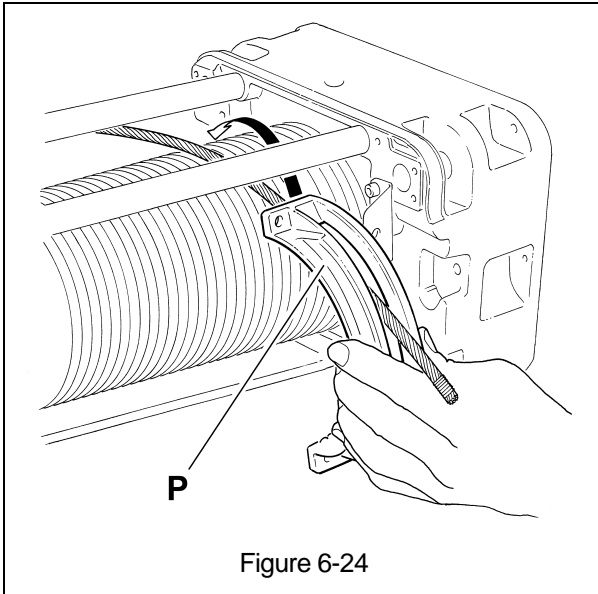
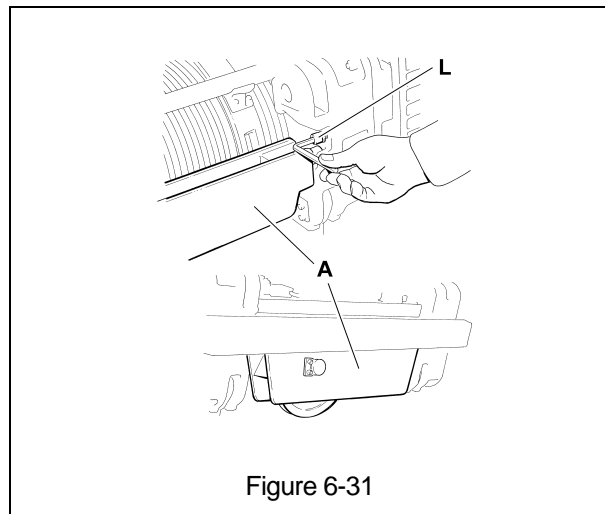
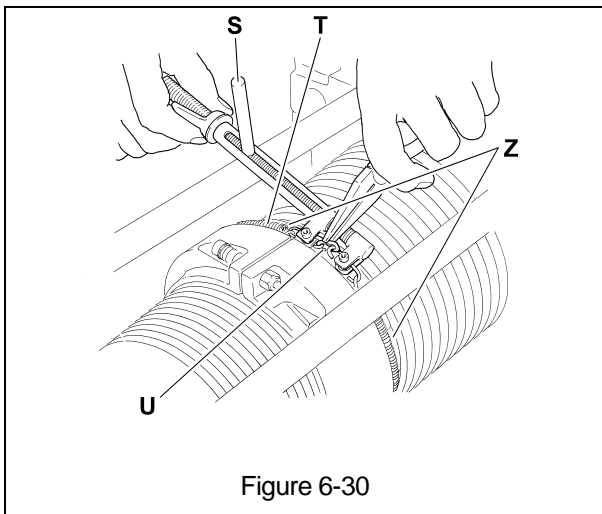
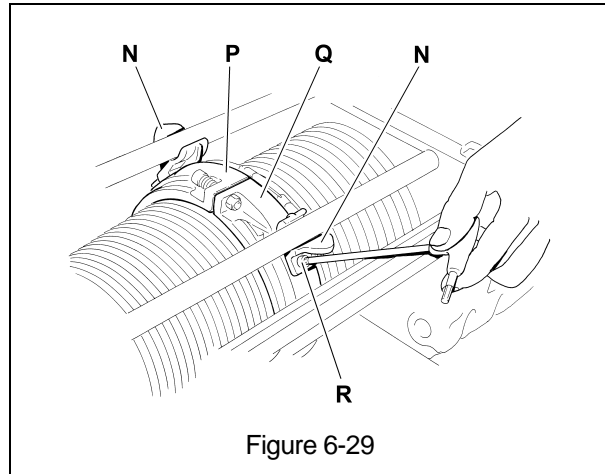
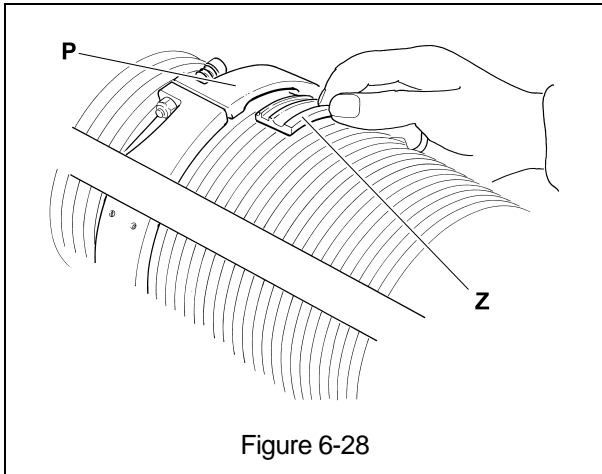

Table 6-1 Rope Clamp Torque Values				
Hoist Size	1	2	3	4
Screw (A1) Dia (mm)	M5	M6	M8	M10
Screw (A1) Torque	45 in-lbs	71 in-lbs	15 ft-lbs	30 ft-lbs

- 7) Press the "UP" button on the Pendant to wind the Wire Rope onto the Drum. Use protective gloves to keep the Wire Rope constantly taut and well placed in the Drum grooves, letting the Wire Rope wind around for at least 10 times (see Figure 6-25).
- 8) Without loosening the tension on the Wire Rope, clamp a weight onto the Wire Rope below the Rope Guide, taking care not to damage the Wire Rope. Replacing the manual tension with the weight will prevent the Wire Rope from unrolling off the Drum (see Figure 6-26).
- 9) Place both Rope Guide Ring Halves (P) and (Q) together on the Drum. Insert the Screws (V) and the Springs (W) and tighten the Lock Nuts (X) until the Springs are partially collapsed, taking care not to over-tighten the Springs, keeping the whole Rope Guide System elastic. Make sure at least 2 threads protrude past the Lock Nuts (X) (see Figure 6-27).



- 10) Insert the Wire Rope Clamp Runners (Z) piece by piece, into the slot on the side of the Rope Guide Ring (P) (see Figure 6-28).
- 11) Reinstall the Limit Switch Actuators (N) onto the Rope Guide Ring Halves (P) and (Q) and tighten the Screws (R) (see Figure 6-29).
- 12) Reposition the Wire Clamping Spring (T) on the Runners (Z). Use the Wire Rope Guide Clamping Tool (S), to pull the Spring taut. Couple the ends of the Clip (U) onto the Spring using the pliers (see Figure 6-30).
- 13) Complete Reassembly:
 - **For OTHER THAN 4/1 Ultra-Low Headroom Version:** Re-seat the Anchorage Cross Head (A) onto the hoist (includes the Sheave Cross Head for 4/1 part/reeved hoists). Reinstall and tighten the Safety Screws (L) (see Figure 6-31). Reinstall the Dust Cover Halves (K) and tighten the four (4) Screws (J) (see Figure 6-33).
 - **For 4/1 Ultra-Low Headroom Version:** Reinstall the Limit Switch Assembly (C1) and tighten the Screws (D1). Do not disconnect or change the setting of the Limit Switches (see Figure 6-32). Reinstall the Dust Cover Halves (K) and tighten the four (4) Screws (J) (see Figure 6-33).



- 14) Carry out again all the sequences described in Section 3.6 "Reeving and Adjustments". Lubricate the Wire Rope, the Rope Guide and Drum (see Section 6.1).

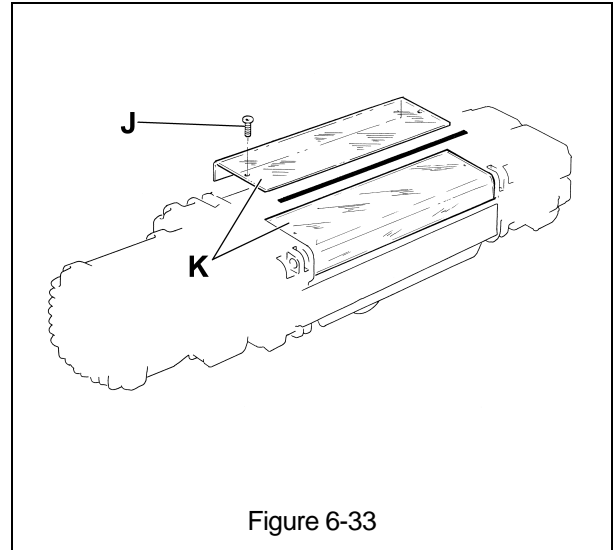
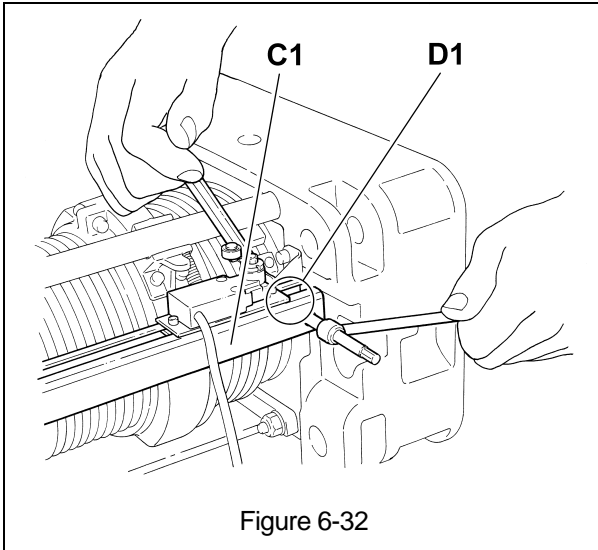

6.5 Storage

- 6.5.1 The storage location should be clean and dry.
- 6.5.2 Care should be taken to not damage any of the electrical power cords or fittings.

6.6 Outdoor Installations

- 6.6.1 For trolley and hoist installations that are outdoors, the trolley and hoist should be covered and protected from the weather at all times.
- 6.6.2 Possibility of corrosion on components of the trolley increases for installations where salt air and high humidity are present. The hoist and trolley may require more frequent lubrication. Make regular inspections of the unit's condition and operation.

7.0 Troubleshooting

WARNING

HAZARDOUS VOLTAGES ARE PRESENT IN THE HOIST AND IN CONNECTIONS BETWEEN COMPONENTS.

Before performing ANY troubleshooting on the equipment, de-energize the supply of electricity to the equipment, and lock and tag the supply device in the de-energized position. Refer to ANSI Z244.1, "Personnel Protection - Lockout/Tagout of Energy Sources."

Only Trained and competent personnel should inspect and repair this equipment.

Table 7-1 Troubleshooting Guide

Symptom	Cause	Remedy
Hoist and/or Trolley moving in wrong direction	Power supply reversed phased	Switch two (2) of the three (3) power supply cord wires at the power source.
	Improper electrical connections	Refer to wiring diagram and check all connections.
Hoist and/or Trolley will not operate	Loss of power	Check circuit breakers, switches, fuses and connections on power lines/cable.
	Wrong voltage or frequency	Check voltage and frequency of power supply against the rating on the nameplate of the motor.
	Hoist overload	Reduce load to within rated capacity of hoist.
	Motor overheated and thermal overload protector has tripped	See Trouble Shooting Problem "Motor or brake overheating".
	Improper, loose, or broken wire in hoist electrical system	Shut off power supply, check wiring connections on hoist control panel and inside push-button pendant.
	Brake does not release	Check motor brake adjustment for proper clearance.
	Defect in control transformer	Check transformer coil for signs of overheating. Disconnect transformer and check for open winding.
	Faulty magnetic contactor	Check coil for open or short circuit. Check all connections in the control circuit. Check for open contactors. Replace as needed.
	Faulty Up or Down Limit Switch	Replace the Up and/or Down Limit Switch
	Motor burned out	Replace motor frame/stator, shaft/rotor, and any other damaged parts.

Table 7-1 Troubleshooting Guide		
Symptom	Cause	Remedy
Hoist lifts but will not lower	Down circuit open	Check circuit for loose connections. Check down limit switch for malfunction.
	Broken conductor in pendant cord	Check the continuity for each conductor in the cable. If one is broken, replace entire cable.
	Faulty magnetic contactors	Check coils for open or short circuit. Check all connections on motor circuit. Check for burned contacts. Replace as needed.
	Faulty switch in pendant	Check electrical continuity. Check electrical connections. Replace or repair as needed.
Hoist lowers but will not lift	Hoist overloaded	Reduce load to within rated capacity of hoist.
	Low voltage in hoist's power supply	Determine cause of low voltage and bring to within plus or minus 10% of the voltage specified on the motor nameplate. The voltage should be measured at the hoist contactor.
	Up circuit open	Check circuit for loose connections. Check up limit switch for malfunction.
	Faulty magnetic contactors	Check coils for open or short circuit. Check all connections on motor circuit. Check for burned contacts. Replace as needed.
	Broken conductor in pendant cord	Check the continuity of each conductor in the cable. If one is broken, replace entire cable.
	Faulty switch in pendant	Check electrical continuity. Check electrical connections. Replace or repair as needed.
Hoist will not lift rated load or does not have the proper lifting speed	Hoist overloaded	Reduce load to within rated capacity.
	Low voltage in hoist's power supply	Determine cause of low voltage and bring to within plus or minus 10% of voltage specified on the motor nameplate. The voltage should be measured at the hoist contactor.
	Brake drags	Check motor brake adjustment for proper clearance.
Load drifts excessively when hoist is stopped	Motor brake not holding	Clean and inspect brake lining. Check brake adjustment for proper clearance.
Trolley drifts excessively when stopping	Motor brake not holding	Clean and inspect brake lining. Check brake adjustment. Replace if necessary
Hoist and/or Trolley Motor or brake overheating	Excessive load	Reduce load to within rated capacity of hoist.
	Excessive duty cycle	Reduce frequency of lifts and/or trolley movement.
	Wrong voltage or frequency	Check voltage and frequency of power supply against the rating on the nameplate on the motor.
	Brake drags	Check brake adjustment for proper clearance.
	Extreme external heating	Above an ambient temperature of 104°F, the frequency of hoist operation must be reduced to avoid overheating of the motor. Special provisions should be made to ventilate the hoist or otherwise shield it from the heat.

Table 7-1 Troubleshooting Guide

Symptom	Cause	Remedy
Hoist and/or Trolley operates intermittently	Contactors contacts arcing	Check for burned contacts. Replace as needed.
	Loose connection in circuit	Check all wires and terminals for bad connections. Replace as needed.
	Broken conductor in Pendant Cord	Check for intermittent continuity in each conductor of the Pendant Cord. Replace entire Pendant Cord if continuity is not constant.
Trolley making loud noise.	Trolley wheel maladjusted on beam	Readjust the gap between the trolley wheel flange and the beam flange.
Trolley will not move	Trolley wheel spacing on beam too tight	Readjust the gap between the trolley wheel flange and the beam flange.
Abnormal noise from wire rope and/or drum	Lack of lubrication, worn wire rope/drum/sheaves	Lubricate or replace wire rope/drum/sheaves

8.0 Warranty

Warranty explanation and terms.

All products sold by Harrington Hoists, Inc. are warranted to be free from defects in material and workmanship from date of shipment by Harrington for the following periods:

Manual Hoists & Trolleys - 2 years

Air and Electric Powered Hoists, Trolleys, and Crane Components - 1 year

Spare / Replacement Parts - 1 year

The product must be used in accordance with manufacturer's recommendations and must not have been subject to abuse, lack of maintenance, misuse, negligence, or unauthorized repairs or alterations.

Should any defect in material or workmanship occur during the above time period in any product, as determined by Harrington Hoist's inspection of the product, Harrington Hoists, Inc. agrees, at its discretion, either to replace (not including installation) or repair the part or product free of charge and deliver said item F.O.B. Harrington Hoists, Inc. place of business to customer. Customer must obtain a Return Goods Authorization as directed by Harrington or Harrington's published authorized repair center prior to shipping product for warranty evaluation. An explanation of the complaint must accompany the product. Product must be returned freight prepaid. Upon repair, the product will be covered for the remainder of the original warranty period. If it is determined there is no defect, or that the defect resulted from causes not within the scope of Harrington's warranty, the customer will be responsible for the costs of returning the product.

Harrington Hoists, Inc. disclaims any and all other warranties of any kind expressed or implied as to the product's merchantability or fitness for a particular application. Harrington will not be liable for death, injuries to persons or property or for incidental, contingent, special or consequential damages, loss or expense arising in connection with the use or inability whatever, regardless of whether damage, loss or expense results from any act or failure to act by Harrington, whether negligent or willful, or from any other reason.

HARRINGTON HOISTS AND CRANES

www.harringtonhoists.com

Harrington Hoists, Inc.
401 West End Avenue
Manheim, PA 17545
Phone: 717-665-2000
Toll Free: 800-233-3010
Fax: 717-665-2861

Harrington Hoists – Western Division
2341 Pomona Rd. #103
Corona, CA 92880-6973
Phone: 909-279-7100
Toll Free: 800-317-7111
Fax: 909-279-7500

RHOM