

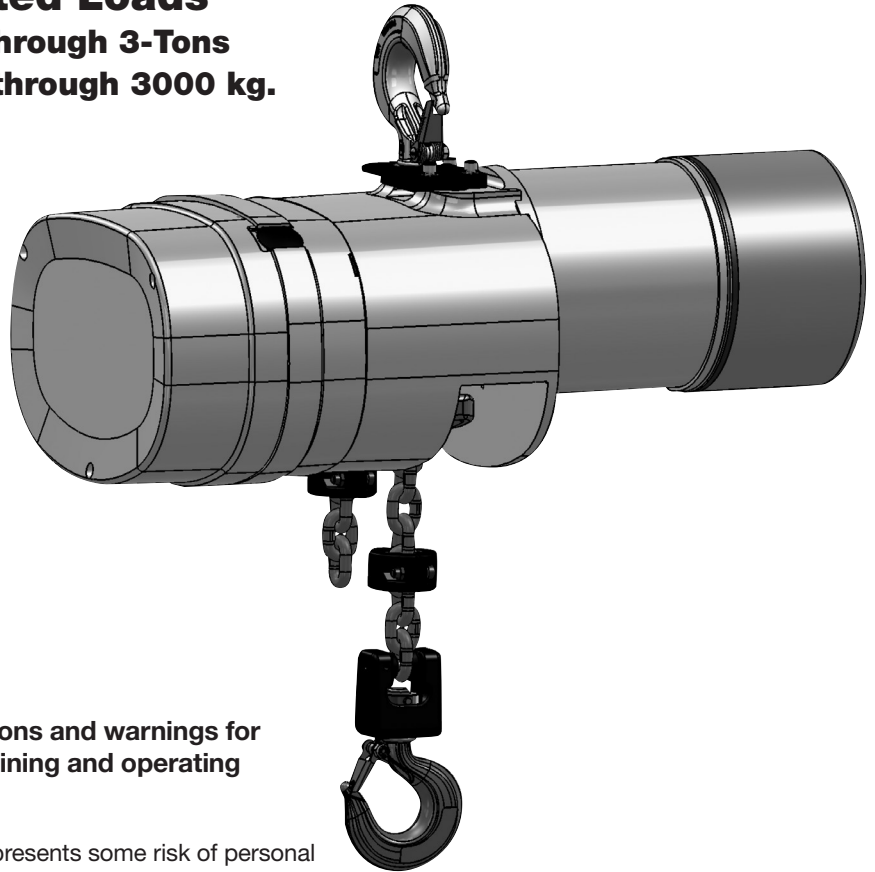

# MAN GUARD™

**Rated Loads**  
**1/4 through 3-Tons**  
**250 kg through 3000 kg.**



**Follow all instructions and warnings for inspecting, maintaining and operating this hoist.**

The use of any hoist presents some risk of personal injury or property damage. That risk is greatly increased if proper instructions and warnings are not followed. Before using this hoist, each operator should become thoroughly familiar with all warnings, instructions, and recommendations in this manual.

**Retain this manual for future reference and use.**

**Forward this manual to the hoist operator.**

Failure to operate the equipment as directed in the manual may cause injury.

Before using the hoist, fill in the information below. Refer to the identification plate.

Model No. \_\_\_\_\_  
Serial No. \_\_\_\_\_  
Purchase Date \_\_\_\_\_  
Voltage \_\_\_\_\_  
Rated Load \_\_\_\_\_

## FOREWORD

This book contains important information to help you install, operate, maintain and service your new Electric Hoist. We recommend that you study its content thoroughly before putting your hoist into use. Then, through proper installation, application of correct operating procedures, and by practicing the recommended maintenance suggestions you will be assured maximum lifting service from the hoist.

Complete inspection, maintenance and overhaul service is available for CM Man Guard™ Electric Hoists at Authorized Repair Stations. All are staffed by qualified factory-trained service men; have authorized testing equipment; and stock a complete inventory of factory approved CM Man Guard replacement parts.

Complete replacement parts information is given in Section IX. It will likely be a long time before parts information is needed, therefore, after you completely familiarize yourself with operation and preventive maintenance procedures, we suggest that this instruction and parts manual be carefully filed for future reference.

**Notice:** Use only factory approved CM Man Guard replacement parts, available from Authorized Repair Stations or CM Man Guard Hoist Distributors.

The "Accident Prevention Manual for Industrial Operations" (8th Edition) by the National Safety Council states:

"Employees who work near cranes or assist in hooking on or arranging loads should be instructed to keep out from under loads. Supervisors should watch closely to see that this rule is strictly followed.

From a safety standpoint, one factor is paramount: conduct all lifting operations in such a manner that if there were an equipment failure, no personnel would be injured. This means keep out from under raised loads!"

**THE INFORMATION CONTAINED IN THIS MANUAL IS FOR INFORMATIONAL PURPOSES ONLY AND CM MAN GUARD HOISTS DOES NOT WARRANT OR OTHERWISE GUARANTEE (IMPLIEDLY OR EXPRESSLY) ANYTHING OTHER THAN THE COMPONENTS THAT CM MAN GUARD MANUFACTURES AND ASSUMES NO LEGAL RESPONSIBILITY (INCLUDING, BUT NOT LIMITED TO CONSEQUENTIAL DAMAGES) FOR INFORMATION CONTAINED IN THIS MANUAL.**

## INDEX

SECTION I	GENERAL DESCRIPTION	Page
Paragraph	1-1 General	3
Paragraph	1-2 Hoist Service Classification	3
Paragraph	1-3 Basic Construction	3
Paragraph	1-4 Differences Between Models and Sizes	4
Paragraph	1-5 <b>MAN GUARD</b> Overload Clutch	4
<b>SECTION II INSTALLATION</b>		
Paragraph	2-1 General	4
Paragraph	2-2 Installation	4
Paragraph	2-3 Pre-Installation Checks	5
Paragraph	2-4 Connecting Hoist to Electrical Service	5
<b>SECTION III OPERATION</b>		
Paragraph	3-1 General	6
Paragraph	3-2 Operating Hoist	6
Paragraph	3-3 Pulling and Rotating Hoist and Load	6
Paragraph	3-4 Upper and Lower Limit Stops	6
Paragraph	3-5 <b>MAN GUARD</b> Overload Clutch Operations	6
Paragraph	3-6 Operating Precautions	7
<b>SECTION IV LUBRICATION</b>		
Paragraph	4-1 General	8
Paragraph	4-2 Change Gear Case Oil	8
Paragraph	4-3 Lubricate Load Chain	8
Paragraph	4-4 Lubricate Upper Hook and Lower Block Assembly	8
Paragraph	4-5 Lubricate Limit Lever Control Shaft and Gears	8
<b>SECTION V MAINTENANCE</b>		
Paragraph	5-1 General	8
Paragraph	5-2 Thirty-Day Inspection	8
Paragraph	5-3 Six-Month Inspection	11
Paragraph	5-4 Inspection 5000 Hour or Five Year	11
<b>SECTION VI TROUBLE SHOOTING CHART</b>		
12-13		
<b>SECTION VII DISASSEMBLY AND REASSEMBLY</b>		
Paragraph	7-1 Rebuild of Load Brake and Overload Clutch Assembly	14
Paragraph	7-1a Overload Clutch without Load Brake	15
Paragraph	7-2 Brake Adjustment	16
Paragraph	7-3 Testing Hoist	19
Paragraph	7-13 Test Procedure For Checking Operation of Overload Clutch	19
<b>SECTION IX REPLACEMENT PARTS</b>		
		20

**Notice:** Information contained in this book is subject to change without notice.

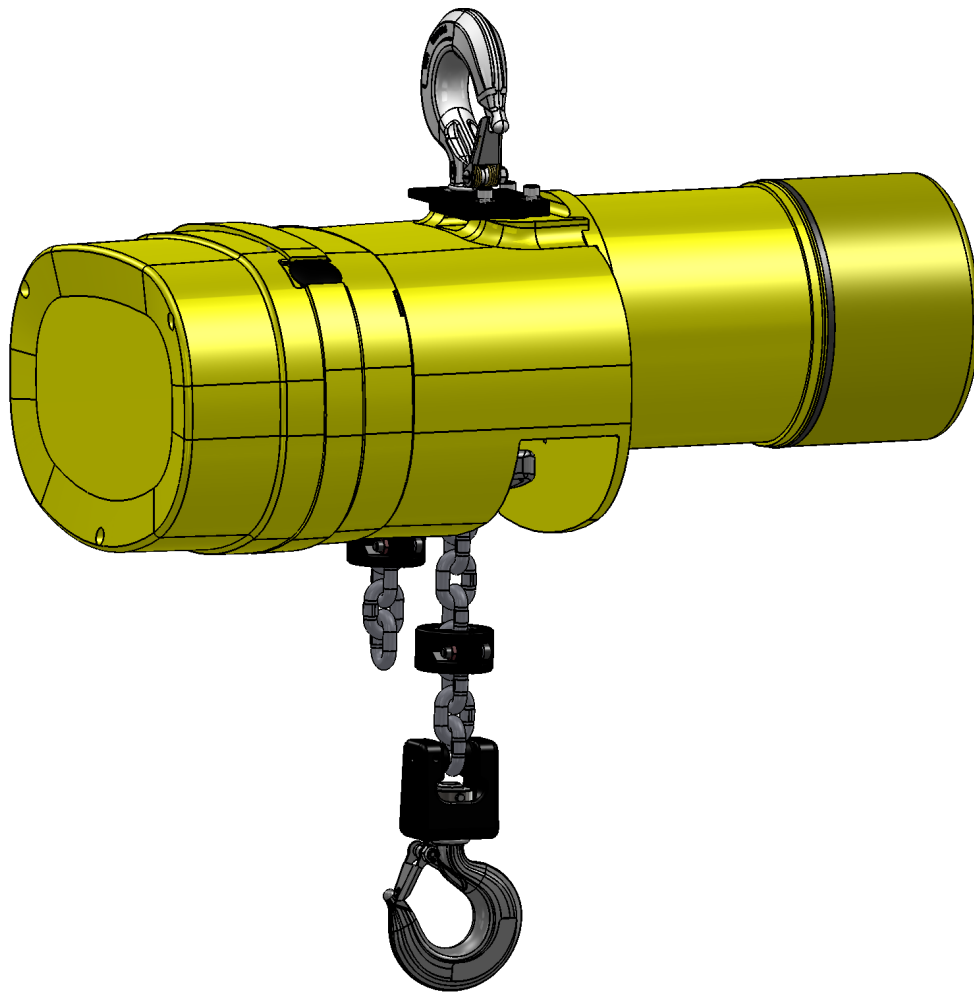

Figure 1-1. Typical CM Man Guard Electric Hoist

## SECTION I - GENERAL DESCRIPTION

1-1. GENERAL. **CM Man Guard** Portable Electric Hoists are precision built chain type hoists ranging in five rated load sizes from 1/4 ton through 3 tons with various lifting speeds and electrical power supplies. In addition to the capacities, there are model variations with hook or lug type suspension, and single or variable speed.

### 1-2. HOIST SERVICE CLASSIFICATION

a. **CM Man Guard** electric hoists at the time of manufacture comply with our interpretation of applicable sections of ANSI B30.16 "Overhead Hoists", National Electric Code ANSI/ NFPA 70 and Occupational Safety and Health Act, 1992.

b. OSHA places the burden of compliance for hoist installations on the user. The user must install the equipment in accordance with the National Electric Code ANSI/NFPA 70 as well as other federal, state and local regulations which apply to the installation and application in your particular area.

c. These hoists meet ANSI/ASME HST-1M "Performance Standard for Electric Chain Hoists" hoist duty class ratings as outlined in the sales bulletin.

## **▲ WARNING**

**Equipment covered herein is not designed or suitable as a power source for lifting or lowering persons. Do not use as an elevator.**

1-3. BASIC CONSTRUCTION. All sizes and models of these **CM Man Guard** Electric Hoists are of the same basic designs, having many common and interchangeable parts. They consist primarily of an aluminum alloy frame and gear case cover which houses the gear train. An electric driving motor and external motor brake are mounted on the rear of the frame, Electrical control components are mounted on front of the gear case cover and encased by aluminum alloy end cover. An upper hook or lug bracket for suspending the hoist is attached to the top of the frame. A high strength low alloy coil load chain with lower block assembly is employed to raise and lower loads. Hoist operation is controlled by a pendant push button station.

1-4. DIFFERENCES BETWEEN MODELS AND SIZES. The main differences between hoist models are in the service classification, type of load chain and the suspension employed. These are described in paragraphs (a) through (c), below. The differences between sizes of hoists are in the number of gear reductions used and the reeving of the load chain. Two-reduction gearing is used for 1/4 through 1/2 ton rated load hoists; three-reduction gearing for 1, 2 and 3 ton rated hoists. On 1/4 through 1 ton rated load hoists, the load chain is single reeved (one part of chain); on 2 ton rated loads, the chain is double reeved (two parts of chain); on three ton rated loads, the chain is triple reeved (three parts of chain).

a. Coil type chain is full-flexing electric welded link chain. It is especially designed for use with your CM Electric Hoists and only factory approved chain of the correct size, pitch, hardness, and strength can be used with these hoists.

b. Suspension differences include a conventional hook type mounting and a lug type mounting. Hook suspension allows portability permitting hoist to be easily moved from job to job. Lug suspension permits hoist to be rigidly mounted to overhead structure or attached to CM Man Guard Rigid Mount Trolleys, affording unusual headroom advantage.

1-5. **MAN GUARD OVERLOAD CLUTCH.** CM Electric Hoists having a **MAN GUARD** label are equipped with an overload clutch that is designed to help guard against excessive overloads. It is a cone-friction clutch that connects the first reduction gear to the clutch pinion shaft. A Belleville disc spring provides clutch pressure between the gear and its cone shaped gear center. An excessive overload causes the gear to rotate without turning the gear center and pinion shaft. See paragraph 3-5 for operation.

<b>⚠ WARNING</b>
<b>THE MAN GUARD OVERLOAD CLUTCH IS A PROTECTIVE DEVICE THAT WILL PERMIT OPERATION OF YOUR HOIST WITHIN ITS RATED LOAD AND WILL PREVENT LIFTING OF EXCESSIVE OVERLOADS WHICH CAN CAUSE PERMANENT DEFORMATION OR WEAKENING OF A PROPERLY MAINTAINED HOIST AND/OR ITS SUSPENSION.</b>

## SECTION II - INSTALLATION

2-1. GENERAL. **CM Man Guard** Electric Hoists are completely lubricated and load tested under their own power before being shipped from the factory. To place hoist in service, attach to suitable overhead suspension (par. 2-2) in area to be used; make pre-installation check (par. 2-3); and connect to the proper power supply (par 2-4).

2-2. INSTALLATION.

<b>NOTICE</b>
Lubricate load chain before operating hoist. See paragraph 4.3

a. On hook suspended hoists, select a suitable overhead support in area hoist is to be used (one capable of holding weight of hoist and its rated load) and hang up hoist. Be certain upper hook is firmly seated in center of hook saddle. Upper hook is equipped with a spring type hook latch; it may be necessary to remove latch to attach hook to support. Replace latch after hoist is installed.

b. On lug suspended hoists, select a suitable overhead support in area hoist is to be used (one capable of holding weight of hoist and its rated load). Mount hoist using through bolts, of appropriate size, to fit mounting holes in suspension lug at top of hoist frame. (See table below.) The structure used to suspend hoist must be of sufficient strength to withstand reasonable forces to which hoist and support may be subjected. Hoist must be aligned with load to avoid side pulls.

c. On lug suspended hoists, the suspension lug is factory oriented to cross mount the hoist. This is the recommended orientation. To rotate the lug 90° for parallel mounting, follow instructions below:

(1) On 1/4 through 1 ton hoists, remove the two screws securing the anti-rotation bracket and remove the bracket. Rotate the suspension lug in 90° increments. Reinstall the anti-rotation bracket and secure with two screws and lock washers.

(2) On 2 ton hoists, remove hex socket head screw in lower lock plate. Remove lower lock plate. Rotate suspension lug to selected position and replace lock plate and hex socket head screw.

(3) On 3 ton hoists, the hanger bracket must first be removed from the hoist to provide access to suspension nut. With bolt removed lift lug from hanger and reposition as desired. The lug is located and prevented from turning by integral lugs on adjacent surfaces of the lug and the hanger. Reinstall suspension bolt, spherical washers and nut. Align hole in nut and suspension bolt. Reassemble hanger bracket to hoist.

d. On rigid mount trolley suspended hoists, the trolley side plates must be properly spaced so trolley will fit I-beam on which hoist will operate. Adjustment for various I-beam sizes is accomplished by rearrangement of spacer washers on through bolts which connect trolley side plates to suspension lug on hoist. Refer to instruction sheet furnished with CM Man Guard Rigid Mount Trolleys for complete instructions.

## SUSPENSION LUG BOLT SIZES AND SPACING

Hoist Rated Load (tons)	Bolt Diameter (in)	Distance Between Holes (in)
1/4, 1/2 & 1	5/8	3-1/8
2	1	5
3	1-1/4	6

### 2-3. PRE-INSTALLATION CHECK.

**Check Oil Level** (Fig. 4-1). The gear case has been filled with oil, to the proper level at the factory. However, the oil level should be checked before hoist is operated. Remove pipe plug from oil filler on side of hoist frame. Replace with supplied oil hole cover. Check oil level by removing oil level plug (side of frame). Observe if oil level is even with bottom of tapped hole. If it is not, add oil, as specified in paragraph 4-2c. Also check load chain. Be sure it is properly lubricated. See para. 4-3.

### Check Limit Stops:

**Paddle limit equipped.** Make sure the actuator on the tail chain side is securely connected to the proper link. (See chart on page 30). On single part hoists, make sure steel actuator is connected to the first chain link above the lower block. Multiple part reeved hoists do not have an actuator on the lower block side.

### 2-4. CONNECTING HOIST TO ELECTRICAL SERVICE.

a. All hoists are equipped with a flexible power cable extending from the hoist. A grounding type male plug or permanent connection in an outlet box may be used for connecting hoist to power supply. See table (fig. 2-1) for branch circuit conductor sizes.

H.P.	Power Supply	AWG Wire Size					
		#16	#14	#12	#10	#8	#6
1/4	115-1-60	80	130	210	330		
	230-1-60	230	330	835			
	230-3-60	465	740	1180			
	460-3-60	1440	2390				
1/2	115-1-60	45	75	120	190	310	490
	230-1-60	195	305	490	775	1235	
	230-3-60	280	450	715	1135		
	460-3-60	860	1440				
1	115-1-60	*	45	75	120	190	300
	230-1-60	120	190	300	475	720	
	230-3-60	180	290	460	730		
	460, 575-3-60	560	900				
2½	230-3-60	60	100	150	250		
	460, 60	260	420				

\*Do not use

Figure 2-1. Branch Circuit Conductor Size. Maximum length in feet for wire size based on horsepower and power supply. Wire size for entire length of branch circuit and permanent wiring to main feeder. Power supply measured at hoist, while running and with normal load, must not vary more than ±5% of voltage on motor nameplate.

b. Follow local & National Electrical Codes when providing electrical service to hoist. Connect power wires in accordance with appropriate wiring diagram. Power supply must be the same voltage, frequency and phase as specified on the hoist nameplate.

## WARNING

The green wire provided in the power supply cable is a grounding wire and must be connected to a proper ground. (Follow local code requirements and/or National Electrical Code Article 250).

c. Dual voltage hoists with reconnectable 230/460 volts, 3 phase, 60 hertz are (unless otherwise specified on customer's order) shipped from factory pre-connected for operation on 230 volts. If hoist is to be operated on 460 volts convert wiring by changing connections on terminal board. With hoist disconnected from power source, remove electrical compartment cover and reconnect terminal board leads. Refer to Wiring Diagram.

d. Dual voltage hoists with reconnectable 115/230 volts, 1 phase, 60 hertz are (unless otherwise specified on customer's order) shipped from factory pre-connected for operation on 115 volts. If hoists are to be operated on 230 volts convert wiring by changing connections on terminal board. With hoist disconnected from power source, remove electrical compartment cover and reconnect terminal board leads. Also refer to Wiring Diagram.

## WARNING

On electrically operated hoists it is possible to have "Reverse Phasing" causing the lower block to raise when the down button is depressed. When this condition exists, the block operated limit switches will not function properly. Serious damage to the hoist can occur with resulting hazard to operator and load. Hoists must be properly phased each time they are installed or moved to a new power source, or when service is performed on mainline (power source).

## SECTION III - OPERATION

3-1. GENERAL. Operation of **CM Man Guard** Electric Hoists are controlled by a push button station suspended from the hoist electrical compartment. The station has a built-in mechanical interlock to prevent depressing both buttons simultaneously.

### 3-2. OPERATING HOIST.

- a. Depress push button marked “↑” to raise load.
- b. Depress push button marked “↓” to lower loads.
- c. Jogging the push buttons will give “hairline” load movement. The quickness of the depressing motion will determine the amount of movement. Excessive use of this “jogging” feature will cause premature burning of contact points, motor overheating, and rapid motor brake wear.

### 3-3. PULLING AND ROTATING HOIST AND LOAD.

- a. The push button station conductor cable has a built-in strain cable suitable for pulling trolley suspended hoists when not loaded. Do not use for pulling bridge cranes. Push on load or load chain or use a hand geared or motor driven type trolley to traverse loaded hoists.
- b. To rotate hoist and load, push on one corner of load. The lower hook will pivot through 360 degrees to permit load to be swung to the desired position. The upper hook (hook suspension models) is also designed to rotate so that side pulls will swing hoist to face load, thus reducing side thrust.

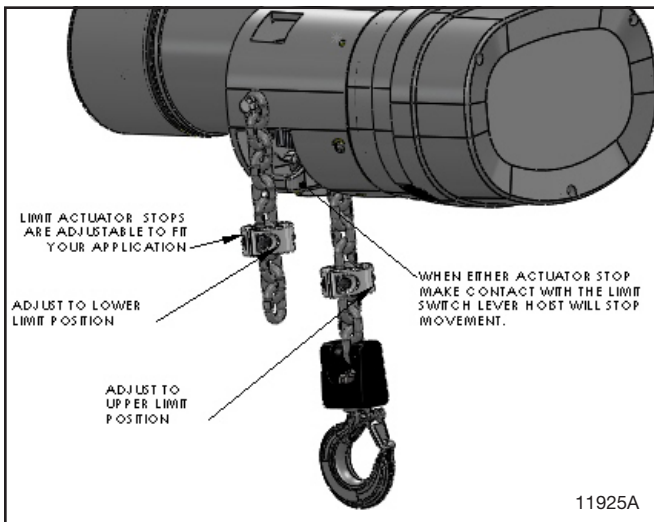

Figure 3-1. Limit Switch Illustration

3-4 UPPER AND LOWER LIMITS. CM Man Guard Electric Hoists are equipped with a paddle type limit switch, operated by the lower block in the up direction and an actuator attached to the chain in the lowering direction.

3-4a. UPPER AND LOWER LIMIT STOPS (paddle limit). A lower block and chain operated limit stop is provided to guard against overtravel of load in either raising or lowering direction, which can cause damage to hoist. When highest position is reached a limit actuator on the load chain, above the lower block, trips the limit lever (fig. 3-1). When lowest position is reached, a limit actuator on the tail end of load chain trips the limit lever (fig. 3-1). The

limit lever is connected to a limit switch that automatically stops the hoist motor. This is intended as a safety device and is not to be used on a routine basis to stop travel of lower block or shut off hoist.

3-5. OVERLOAD CLUTCH OPERATION. The overload clutch is factory preset at assembly so that the hoist will lift its full rated load but will refuse to lift overloads within a range of 150 percent rated load to 200 percent rated load. If the load to be lifted exceeds the clutch factory setting, the motor will continue to run and will rotate the clutch gear without lifting the load. Whenever this occurs, immediately release the “↑” push button to prevent overheating of the clutch friction surfaces and motor, and reduce the load to rated hoist capacity. Should it be impractical to reduce the load, replace the hoist with one of suitable rated capacity.

**NOTE:** Always know load to be lifted. **CM Hoists** does not recommend lifting loads greater than the rated load of your hoist.

### 3-6. OPERATING PRECAUTIONS.

#### **▲ WARNING**

**Equipment covered herein is not designed or suitable as a power source for lifting or lowering persons. Do not use as an elevator.**

Safe operation of an overhead hoist is the operator's responsibility. Following are some basic rules that can make an operator aware of dangerous practices to avoid and precautions to take for his own safety and the safety of others. Observance of these rules in addition to frequent examinations and periodic inspection of the equipment may save injury to personnel and damage to equipment.

- a. **DO** read ANSI B30.16 Safety Standard for Overhead Hoists and the Operation, Service and Parts Manual
- b. **DO** be familiar with hoist operating controls, procedures and warnings.
- c. **DO** make sure hook travel is in the same direction as shown on controls.
- d. **DO** make sure hoist limit switches function properly.
- e. **DO** maintain firm footing when operating hoist.
- f. **DO** make sure that load slings or other approved single attachments are properly sized and seated in the hook saddle.
- g. **DO** make sure that the hook latch, is closed and not supporting any part of the load.
- h. **DO** make sure that load is free to move and will clear all obstructions.
- i. **DO** take up slack carefully, check load balance, lift a few inches and check load holding action before continuing.
- j. **DO** avoid swinging of load or load hook.
- k. **DO** make sure that all persons stay clear of the suspended load.
- l. **DO** warn personnel of an approaching load.
- m. **DO** protect load chain from weld splatter or other damaging contaminants.
- n. **DO** promptly report any malfunction, unusual performance, or damage of the hoist.
- o. **DO** inspect hoist regularly, replace damaged or worn parts, and keep appropriate records of maintenance.
- p. **DO** use the hoist manufacturer's recommended parts when repairing a hoist.
- q. **DO** use hook latches wherever possible.
- r. **DO** apply lubricant to load chain as recommended. **DO NOT** lift more than rated load.
- s. **DO NOT** use the hoist load limiting device to measure the load.
- t. **DO NOT** use damaged hoist or hoist that is not working correctly.
- u. **DO NOT** use the hoist with twisted, kinked, damaged or worn chain.
- v. **DO NOT** lift a load unless chain is properly seated in chain wheel(s) or sprocket(s).
- w. **DO NOT** use load chain as a sling or wrap chain around the load.
- x. **DO NOT** lift a load if any binding prevents equal loading on all supporting chains.
- y. **DO NOT** apply the load to the tip of the hook.
- z. **DO NOT** operate unless load is centered under hoist.
- aa. **DO NOT** allow your attention to be diverted from operating the hoist.
- ab. **DO NOT** operate the hoist beyond limits of load chain travel.
- ac. **DO NOT** use limit switches as routine operating stops. They are emergency devices only.
- ad. **DO NOT** use hoist to lift, support or transport people.
- ae. **DO NOT** lift loads over people.
- af. **DO NOT** leave a suspended load unattended unless specific precautions have been taken.
- ag. **DO NOT** allow sharp contact between two hoists or between hoist and obstructions.
- ah. **DO NOT** allow the chain or hook to be used as a ground for welding.
- ai. **DO NOT** allow the chain or hook to be touched by a live welding electrode.
- aj. **DO NOT** remove or obscure the warnings on the hoist.
- ak. **DO NOT** adjust or repair a hoist unless qualified to perform hoist maintenance.
- al. **DO NOT** attempt to lengthen the load chain or repair damaged load chain.
- am. **DO NOT** allow personnel not physically fit or properly qualified to operate the hoist.
- an. **DO NOT** operate hoist unless upper and lower limit switch stops are operating properly.
- ao. **DO** always be sure there is no twist in coil load chain. On 2 & 3 ton coil chain hoists, check to see that lower block is not capsized between strands of chain.
- ap. **DO** avoid operating hoist when hook is not centered under hoist. Be sure that hoist trolley or other support mechanism is correctly positioned for handling the load before lifting.
- aq. **DO** operate hoist within recommended duty cycle and do not "jog" unnecessarily.
- ar. **DO** conduct regular visual inspections for signs of damage or wear.
- as. **DO NOT** operate hoist with hooks that have opened up. See Figures 5-5 and 5-6.
- at. **DO** provide supporting structure or anchoring means that has a load rating at least equal to that of the hoist.
- au. **DO NOT** use hoists in locations that will not allow operator movement to be free of the load.
- av. **DO** when starting to lift or pull, move the load a few inches at which time the hoist should be checked for proper load holding action. The operation shall be continued only after the operator is assured that the hoist is operating properly.
- aw. **DO NOT** leave a loaded hoist unattended at the end of a work shift or for extended periods during the work shift. Where operations are such that this condition cannot be avoided the operator must be assured that the condition does not create a hazard to personnel or property.
- ax. **DO** use common sense and best judgement whenever operating a hoist. Observe American National Standard Safety standard, ANSI B30.16, latest issue.

## SECTION IV - LUBRICATION

4-1. GENERAL. The lubrication services outlined in paragraphs 4-2 through 4-5 should be performed at regular intervals to maintain top hoist performance and insure long life. The frequency for lubrication services will depend on the type of hoisting service that hoist is subjected to and should coincide with periodic preventive maintenance inspection. See Section V-Maintenance.

4-2. CHANGE GEAR CASE OIL (Fig. 4-1).

- Remove drain plug from bottom of hoist frame and drain oil from gear case. Replace plug.
- Remove oil level plug from side of hoist.
- Refill gearcase through oil filler to proper level (bottom of oil level plug hole) using Automatic Transmission Fluid - DEXRON Type. This is an all-weather oil available from all major oil companies. 1-1/2 pints of oil are required.
- Reinstall oil level plug and breather.

4-3. LUBRICATE LOAD CHAIN. A small amount of lubricant will greatly increase load chain life, therefore, chain should not be allowed to run without lubricant. Chain should be cleaned and lubricated as directed in paragraph a below. User should set up a regular schedule for chain lubrication after observing operating conditions for a few days. Use Bar and Chain Oil (LUBRIPLATE or equal) on load chain.

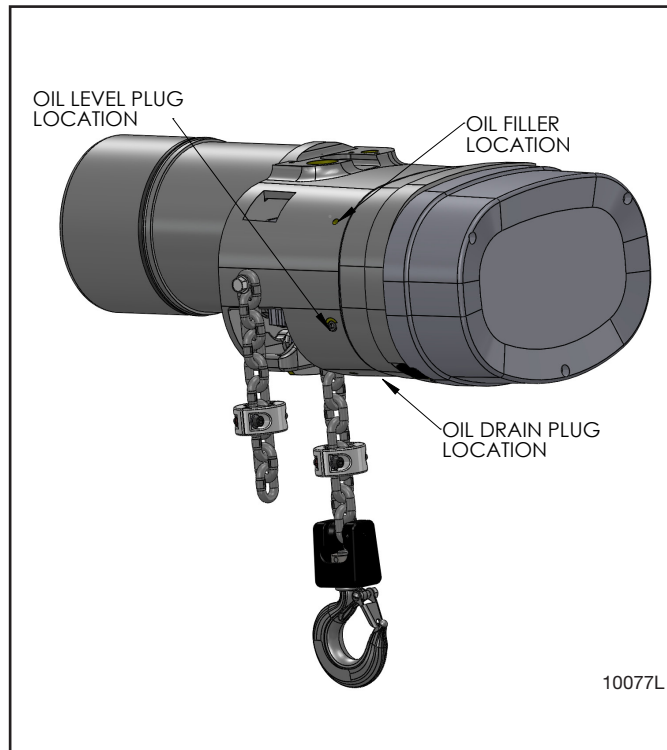

Figure 4-1. Location of Oil Filler and Plugs

a. Coil Chain. Under ordinary conditions only weekly attention will be necessary. Under hot and dirty conditions it may be necessary to clean chain at least once a day and lubricate it several times between cleanings. Thoroughly clean chain with an oil solvent and re-lubricate by coating it lightly with oil. Make sure that lubricant coats wear surfaces between links. Zinc plated load chain should be cleaned and lubricated daily.

4-4. LUBRICATE UPPER HOOK AND LOWER BLOCK ASSEMBLY.

- Apply a few drops of Bar and Chain Oil on shank of upper hook where it enters frame.
- Apply a few drops of Bar and Chain Oil on shank of lower hook where it enters lower block. Hook rotation bearing may be removed for cleaning and re-lubricating if necessary. See section 7-5.
- On lower block assemblies of 2 and 3 ton capacity hoists, also apply heavy duty lithium soap grease with EP additives through pressure fitting in end of sprocket pin to lubricate bearing in chain sprocket.
- On 3 ton model lubricate sprocket in hanger bracket with a few drops of Bar and Chain Oil in hole provided in center of sprocket hub.

4-5. LUBRICATE LIMIT LEVER CONTROL SHAFT AND GEARS.

Apply a few drops of Bar and Chain Oil on limit lever shaft at bearing points.

### **▲ WARNING**

**Before performing any internal work on hoist, be certain power is shut off. Lock main service switch in the open position.**

## SECTION V - MAINTENANCE

5-1. GENERAL. Preventive maintenance services required on **CM Man Guard** Electric Hoists are for the most part, simple periodic inspection procedures to determine condition of hoist components. Below are suggested inspection procedures, based on daily average hoist usage.

5-2. THIRTY-DAY INSPECTION. Hoist may be left suspended.

a. Inspect Load Chain.

(1) Operate hoist under load and observe operation of chain over sprocket in both directions of chain travel. Chain should feed smoothly into and away from the sprocket. If chain binds, jumps or is noisy, first see that it is clean and properly lubricated. If trouble persists, inspect chain as outlined below.

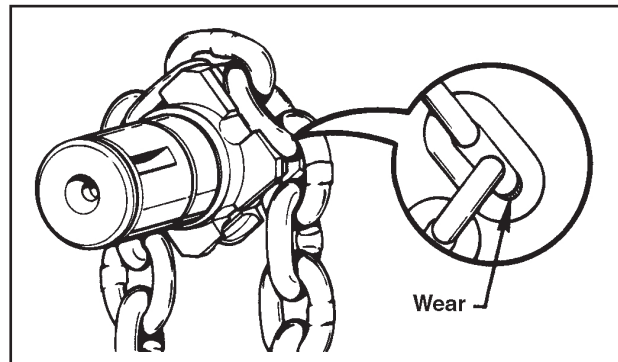

Figure 5-1. Check Chain Wear at Bearing Surfaces Between Links

(2) **Coil Type Load Chain.** Clean chain for inspection. Examine visually for gouges, nicks, weld spatter, corrosion or distorted links. Slacken chain and check bearing surfaces between links



for wear, fig. 5-1. Greatest wear will often occur at sprocket at high or low point of lift, particularly when hoist is subjected to repetitive lifting cycles. Case hardness of chain is about 015" deep. Chain must be replaced before the case is worn through. Also check chain for elongation using a vernier caliper (fig. 5-2). Select an unworn, unstretched section of chain (usually at slack or tail end) and measure and record the length over the number of chain links (pitches) indicated in figure 5-2. Measure and record the same length of a worn section in the load side of the chain. Obtain the amount of wear by subtracting the measurement of the unworn section from the measurement of the worn section. If the result (amount of wear) is greater than the amount specified in the "ALLOWABLE CHAIN WEAR" table, the chain has elongated beyond the maximum allowable length and must be replaced. Chain with excessively pitted, corroded, nicked, gouged, twisted or worn links should be replaced using only factory approved chain. Never weld or attempt to repair coil chain.

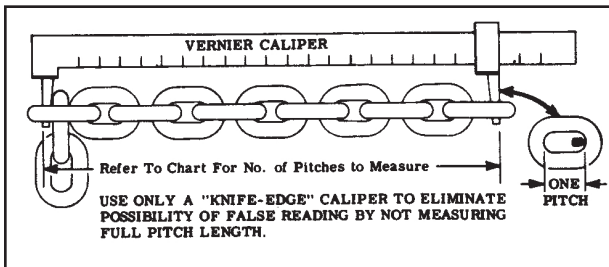

Figure 5-2. Check Coil Chain Using Vernier Caliper

**ALLOWABLE CHAIN WEAR - ELONGATION**

Hoist Rated Load (tons)	Chain Size (wire dia.)	No. of Pitches to Measure	Maximum Wear Limit
1/4 & 1/2	1/4"	13	.145"
1 thru 3	5/16"	11	.142"

**⚠ WARNING**

Do not assume that load chain is safe because it measures below replacement points given herein. Other factors, such as those mentioned in visual checks above, may render chain unsafe or ready for replacement long before elongation replacement is necessary.

**⚠ WARNING**

To avoid serious personal injury from a dropped load caused by chain breakage, when replacing coil load chain, use only factory approved chain conforming to CM Man Guard hoist specifications for material, hardness, strength and link dimensions. Chain not conforming to factory Specifications may be dangerous as it will not fit in the load sprocket and chain guide correctly, causing serious internal damage to hoist and it will wear prematurely, deform and eventually break.

(3) Removing and Replacing Coil Load Chain.

(a) Replacement Coil load chain is installed by attaching it to tail end of old chain, after disconnecting old chain from side of hoist frame and removing limit actuator. New chain is then run into hoist as old chain is run out. Use open "C" links, figures 5-3 and 5-4, for attaching chains. Links must be identical in size to hoist chain - 1/4" wire size with .745" pitch length for 1/4 through 1/2 ton models, 5/16" wire size with .858" pitch for 1 through 3 ton models. Be certain that all welds on links of replacement chain face away from center of load sprocket.

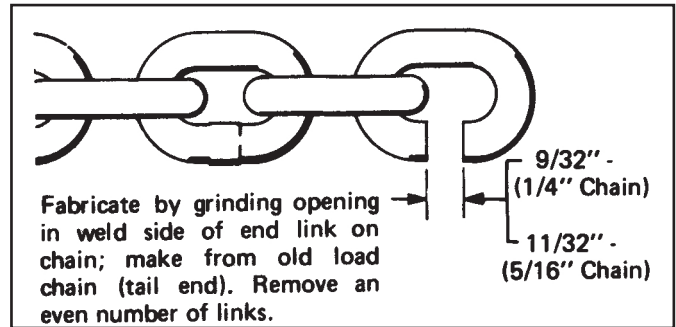

Figure 5-3. Open "C" Link for Removing and Installing Coil Load Chain



Figure 5-4. Installing Coil Load Chain Using Two "C" Links (1/4, 1/2 & 1 ton hoists)

(b) Remove lower block assembly and actuator from old chain and attach them to replacement chain at end which was just run through hoist. Install limit actuator (as noted below) on other end of chain and anchor chain to side of hoist frame.

**NOTICE**

Use one or two "C" links to orient chain for chain anchor screw. Position first link of new chain to be flat against hoist housing without twisting the chain.

On 2 ton double reeved models, also connect opposite end of chain (from lower block) to load chain anchor inside of frame. On 3 ton triple reeved models, the opposite end of the chain is attached to the lower block connecting link.

**NOTE:** In the event the old chain is to be removed from hoist and reinstalled, a short length of chain (about 18" long) must be run into hoist when the old chain is removed. This short length can then be used in the same manner as shown in paragraph 5-2. a.(3). Be sure to use the proper number of open "C" links in order to correctly position end link on tail end of chain to fit anchor at side of hoist frame.

**NOTICE**

To avoid serious internal damage to hoist, when installing coil load chain do not attempt to hand feed chain into hoist, or use a piece of wire in place of the method described herein. To do so may result in serious internal damage to hoist, as coil chain links must be properly seated in chain sprocket before chain is run into hoist. Install chain only as described in this manual.

**⚠ CAUTION**

Keep fingers clear of chain sprocket when replacing load chain.

(4) Check connection of chain to lower block on 1/4 through 1 and 3 ton hoists. Replace parts showing evidence of damage, twisting or elongation.

(5) Check connection of chain to anchor inside hoist frame on double-reeved, 2-ton hoists. Replace parts showing evidence of damage, twisting or elongation. (Also see Sec. VII, par. 7-2. a. (2)).

(6) Lubricate load chain before using hoist. See paragraph 4-3, Section IV.

**b. Inspect Lower Block.**

Hooks shall be removed from service if damage such as the following is visible and shall only be returned to service when approved by a qualified person:

- (1) Missing or illegible hook manufacturer's identification or secondary manufacturer's identification.
- (2) Missing or illegible rated load identification
- (3) Excessive pitting or corrosion
- (4) Cracks, nicks, or gouges
- (5) Wear – any wear exceeding 10% (or as recommended by the manufacturer) of the original section dimension of the hook or its load pin.
- (6) Deformation – any visibly apparent bend or twist from the plane of the unbent hook.
- (7) Throat Opening – any distortion causing an increase in throat opening of 5% not to exceed 1/4" in. (6 mm) (or as recommended by the manufacturer).
- (8) Inability to Lock – any self-locking hook that does not lock.
- (9) Inoperative Latch (if provided) – any damaged latch or malfunctioning latch that does not close the hook's throat.
- (10) Damaged, missing or malfunctioning hook attachment and securing means.

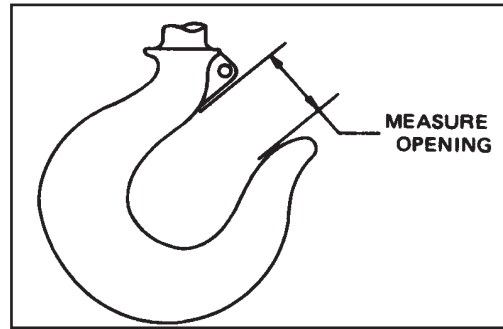

Hoist Rated Load (tons)	Hook Throat Opening
	Normal Opening
1/4 & 1/2	1-1/8
1	1-1/4
2	1-3/8
3	1-1/2

Figure 5-5. Lower Hook Opening (Shown with latch removed for clarity.)

**⚠ WARNING**

Hooks, upper or lower, damaged from chemicals, deformation or cracks or having more than 15 percent in excess of normal throat opening or more that 10 degrees twist from the plane of the unbent hook, or opened, allowing the hook latch to bypass hook tip must be replaced.

Any hook that is twisted or has excessive throat opening indicates abuse or overloading of the hoist. Other load bearing components of the hoist should be inspected for damage. (See Section V. Par. 5-2. d. (2) below).

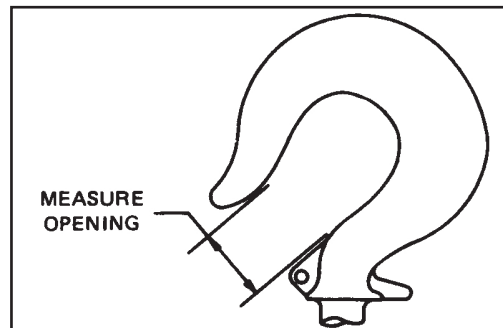

Hoist Rated Load (tons)	Hook Throat Opening
	Normal Opening
1/4 & 1/2	1-1/8
1	1-1/4
2	1-3/8
3	1-1/2

Figure 5-6. Upper Hook Opening (Shown with latch removed for clarity.)

- (11) Thread wear, damage, or corrosion
- (12) Evidence of excessive heat exposure or unauthorized welding.
- (13) Evidence of unauthorized alterations such as drilling, machining, grinding or other modifications.
- (14) On lug suspended models, check condition of suspension lug. Replace lug if damaged or cracked. Check to see that lock plate is in place on lug and screw holding it is tight. (All capacities see figure 7-20).
- (15) On 2-ton hoists, check to see that upper lock plate securing hook or lug bushing is in place and screws holding it are tight. Lubricate hook shank.
- (16) Check hook latch. Replace damaged or broken parts.
- (17) Inspect threaded upper suspension bushing. Verify keeper is in place against flat of suspension bushing, and securing screw and lock washer are in place and tight.

**d. Inspect Motor, Frame and Electrical Compartment Cover.**

- (1) Check to see that bolts securing motor to frame are tight. Also check for any visible damage to motor, such as a cracked end bell or dented stator housing. Replace damaged parts.
- (2) Check hoist frame for signs of visible damage. If frame shows evidence of fracture, the hoist should be disassembled and inspected for further signs of damage from possible overloading. Replace damaged parts.
- (3) Check for possible damage to electrical compartment cover. Be sure screws holding cover are tight.

e. **Check Oil Level.** Remove oil level plug (fig. 4-1). If oil level is not even with bottom of tapped hole, add Automatic Transmission Fluid, DEXRON Type, to bring to proper level.

5-3. SIX-MONTH INSPECTION OR 500-750 HOURS OF OPERATION. Hoist may be left suspended. Same as thirty day inspection plus the following:

a. **Inspect Electrical Controls.** Shut off power supply to hoist and remove electrical compartment cover from hoist. Use caution as some covers contain counterweights.

- (1) Check all wiring and terminals. Insulation should be sound and terminals securely crimped to wires. Terminal screws should be tight and plug-type terminals completely mated. Replace terminals or wires as necessary.
- (2) Check control circuit transformer for evidence of overheating. Replace if necessary.
- (3) Check limit switch to see that wires are securely attached and mounting screws are tight.
- (4) Check contactor solenoid coils and replace coils if they show evidence of overheating.
- (5) Check control cable wire strain reliever to see that it is in good condition and securely attached to gear case cover. Replace rubber strain reliever grommets if damaged.

- a. **Change Gear Case Oil.** See Section IV, paragraph 4-2.
- b. **Relubricate Load Chain.** See Section IV, paragraph 4-3.

c. **Lubricate Upper Hook and Lower Block.** See Section IV, paragraph 4-4.

5-4. INSPECTION: 5000 HOURS "ON" TIME OR 5 YEARS ELAPSED TIME. Hoist must be removed from overhead suspension.

a. **Disassemble Hoist into Subassemblies.** See CM Repair Center.

b. Motor shaft oil seal, sprocket shaft bearing, seal and all gaskets should be replaced.

c. **Inspect Load Brake and Overload Clutch.** Disassemble load brake (if equipped) and clutch assembly as outlined in paragraph 7-4. Friction discs should be discarded and replaced with new discs. Check load brake friction surfaces on flange, ratchet assembly and gear clutch cone. Replace parts if badly scored or worn. Check condition of pawl and ratchet assembly. If pawl, ratchet teeth or pawl spring are broken, damaged or badly worn, replace complete assembly. Check contact faces of load brake cam and gear clutch cone. Brake gear and pinion teeth should be inspected for wear or broken teeth. Clean parts thoroughly with an oil solvent before reassembly.

**NOTE:** The overload clutch assembly should not be disassembled as it is preset at the factory to provide proper clutch pressure for a specific hoist capacity range. If there is evidence of the clutch slipping or wear or damage to the clutch components, the complete clutch assembly should be replaced or sent to an authorized CM Man Guard Hoist Repair Station to be rebuilt and properly adjusted to factory specifications.

d. **Inspect Sprocket and Intermediate Gears.**

(1) On 1 through 3 ton hoists, check condition of gear teeth on intermediate gear and pinion shaft assembly. Replace worn or damaged parts.

(2) Check condition of pockets on chain sprocket (all capacities). Replace worn or damaged parts.

e. **Inspect Motor Brake.** Check braking surfaces for wear and scoring. Replace badly worn or scored parts. Check spring studs and guide pins to make sure they are not bent or loose. Check coil shock mounts for deterioration and damage. Check air gap adjustment. (See 7-11c)

f. **Reassemble and Test Hoist.** Reassemble hoist from subassemblies following procedure outlined in paragraph 7-11. After assembly is complete, test hoist as outlined in paragraphs 7-12 and 7-13.

## SECTION VI - TROUBLE SHOOTING

Trouble	Probable Cause	Remedy
6-1. Hoist Will Not Operate.	<p>a. No power to hoist.</p> <p>b. Wrong voltage.</p> <p>c. No control voltage.</p> <p>d. Loose or broken wire connections in hoist electrical system.</p> <p>e. Contactor assembly not functioning.</p> <p>f. Starting switch burned out (single phase motor).</p> <p>g. Motor burned out.</p>	<p>a. Check switches, circuit breakers and connections in power supply lines. Check power collectors.</p> <p>b. Check voltage required on motor data plate against power supply.</p> <p>c. Check transformer fuse. If blown, check for grounding and/or short in the pushbutton station. Check the transformer coil for signs of overheating. Replace transformer if burned out. Verify the transformer secondary is the same voltage as the coils to which it is connected.</p> <p>d. Shut off power supply, remove electrical cover from hoist and check wiring connections. Also check connections in push button station and limit switches.</p> <p>e. Check for burned out solenoid coil. See that the necessary jumper wires are properly installed.</p> <p>f. Replace burned out parts.</p> <p>g. Replace motor. On single-phase motors the starting switch may be burned out.</p>
6-2. Hook Moves in Wrong Direction.	<p>a. Reverse phasing on three-phase hoists.</p> <p>b. Hoist wired wrong. wiring diagram.</p> <p>c. Starting switch not working correctly (single phase motor).</p>	<p>a. Interchange any two of the three power supply line leads. Do not change green ground lead. Refer to Section II, par. 2-4.</p> <p>b. Check wiring connections with appropriate wiring diagram.</p> <p>c. Check for correct starting switch part number and function. Replace if necessary.</p>
6-3. Hook Will Raise But Not Lower.	<p>a. "DOWN" electrical circuit open.</p> <p>b. Contactor assembly not functioning.</p> <p>c. Push Button Inoperative.</p> <p>d. Load Brake locked up and overload clutch slipping.</p>	<p>a. Check for loose connections. See that necessary jumper wires are properly installed on contactor. Check limit switch condition and electrical connections.</p> <p>b. See that necessary jumper wires are properly installed. Verify that the contactor armatures are free to move. If binding occurs replace contactor. Check for burned out contactor coils.</p> <p>c. Check push button contacts and wires.</p> <p>d. Consult Authorized <b>CM Man Guard</b> Hoist Repair Station.</p>
6-4. Hook Will Lower But Not Raise (continued on next page).	<p>a. Excessive load, causing overload clutch to slip.</p> <p>b. Overload clutch out of adjustment.</p> <p>c. "UP" electrical circuit open.</p>	<p>a. Reduce loading to rated load of hoist, as shown on nameplate.</p> <p>b. Test hoist and replace clutch if hoist will not lift rated load.</p> <p>c. Check for loose connections. See that necessary jumper wires are properly installed on contactor. Check limit switch condition and electrical connections.</p>

## SECTION VI - TROUBLE SHOOTING (Continued)

Trouble	Probable Cause	Remedy
6-4. Hook Will Lower But Not Raise (continued).	<p>d. Contactor assembly not functioning.</p> <p>e. Push button inoperative.</p>	<p>d. See that necessary jumper wires are properly installed. Verify that the contactor armatures are free to move. If binding occurs replace contactor. Check for burned out contactor coils.</p> <p>e. Check push button contacts and wires.</p>
6-5. Hoist Will Not Lift Rated Load.	<p>a. Low voltage</p> <p>b. Overload clutch out of adjustment.</p> <p>c. Motor brake not releasing.</p>	<p>a. See that power supply is same voltage listed on motor data plate. Check size of power supply lines. Refer to fig. 2-1.</p> <p>b. Remove and replace clutch assembly. Refer to Section IV, par. 7-2 and 7-4.</p> <p>c. Check brake components. Refer to Section VII, par 7-2.d, 7-2.e.</p>
6-6. Excessive Drift When Stopping.	<p>a. Excessive load.</p> <p>b. Motor brake not holding.</p> <p>c. Motor brake not setting due to insufficient plunger air gap.</p> <p>d. Load brake not holding.</p>	<p>a. Reduce loading to rated load, shown on nameplate.</p> <p>b. Check brake components. Refer to Section VII, par. 7-2.d.</p> <p>c. Adjust air gap. Refer to Section VII, par. 7-11.c.</p> <p>d. Remove load brake and inspect parts. Refer to Section V, par. 5-4.</p>
6-7. Hoist motor overheats.	<p>a. Excessive load.</p> <p>b. Excessive duty-cycle.</p> <p>c. Excessive "jogging."</p> <p>d. Wrong voltage.</p> <p>e. Starting switch on single-phase motors not opening starting winding.</p> <p>f. Damaged motor or worn bearings in motor or hoist frame.</p> <p>g. Motor brake not releasing.</p>	<p>a. Reduce loading to rated load of hoist, shown on nameplate</p> <p>b. Reduce frequency of lift.</p> <p>c. Reduce frequency of jogs.</p> <p>d. Check voltage rating on motor data plate against power supply.</p> <p>e. Refer to Section VII, par. 7-9.b. (3) (b). Inspect Switch.</p> <p>f. Disassemble hoist and inspect for worn or damaged parts.</p> <p>g. Check brake components. Refer to Section VII, par. 7-2.d.</p>

7-1. REBUILD OF LOAD BRAKE AND OVERLOAD CLUTCH ASSEMBLY. (If hoist is equipped with overload clutch less load brake, see 7-1A.)

a. Disassembly.

(1) Place load brake and clutch assembly, flange up, in a vise equipped with brass or copper jaw plates to protect pinion gear teeth. Remove snap ring of load brake shaft (fig. 7-21).

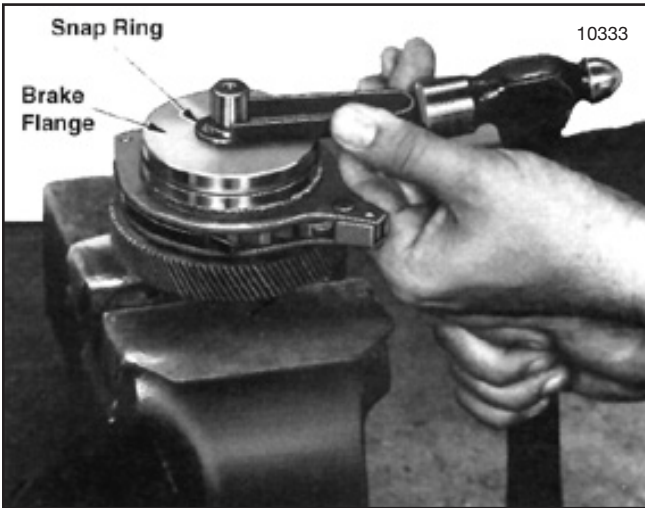

Figure 7-21. Removing Snap Ring from Load Brake Shaft

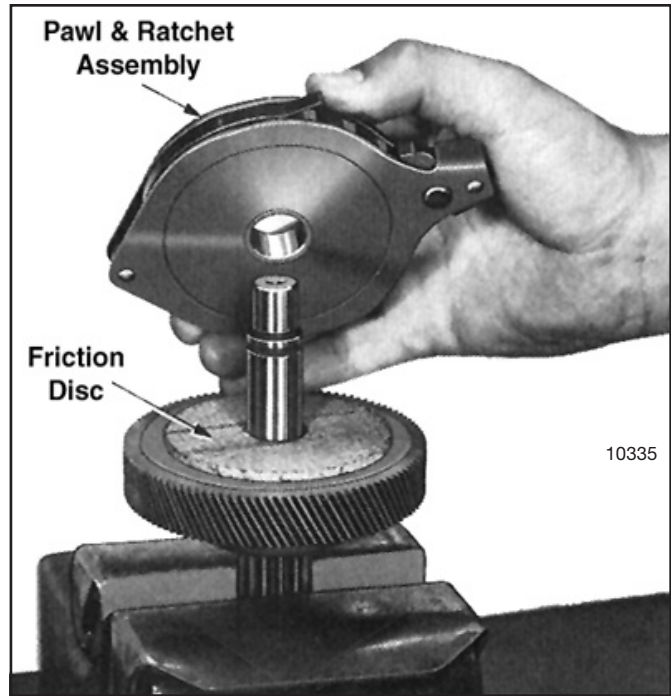

Figure 7-23. Removing Pawl and Ratchet Assembly from Load Brake Shaft

(3) Remove load brake gear and overload clutch assembly from output pinion shaft. Pull the spring from its recess in clutch cone (fig. 7-24) but do not further disassemble gear and clutch assembly. See “NOTE” below.

**NOTE:** Disassembly of the load brake gear and overload clutch assembly (fig. 7-24) is not recommended. Clutch pressure is preset by the factory at assembly to provide the correct torque to allow the clutch to refuse loads within a specified range (150% of rated load to 200% rated load). It is suggested whenever there is a need to repair or readjust the gear and clutch assembly that it be sent to an authorized **CM** Hoist Repair Station where adequate tools, fixtures and appropriate test equipment is available.

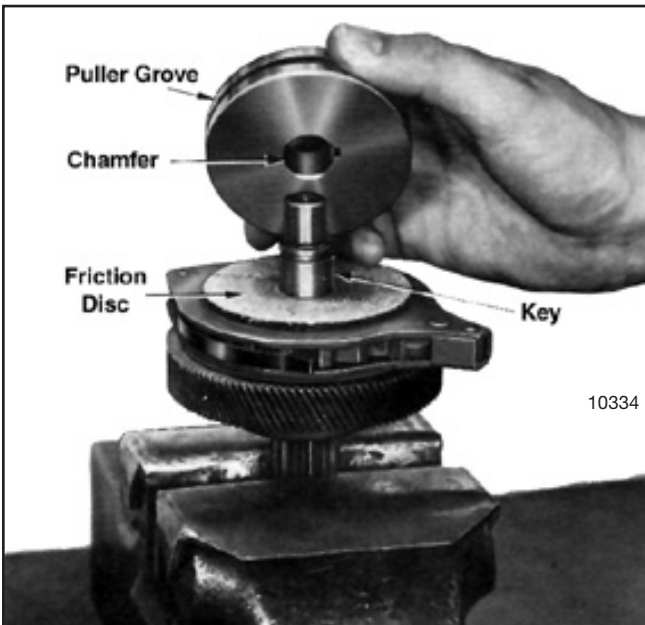

Figure 7-22. View Showing Load Brake Flange Removed

(2) Using a puller tool, remove brake flange from shaft. A groove is provided around outer diameter for this purpose. See figure 7-22. Remove key from shaft and lift off 2 friction discs, and the pawl and ratchet assembly (fig. 7-23).

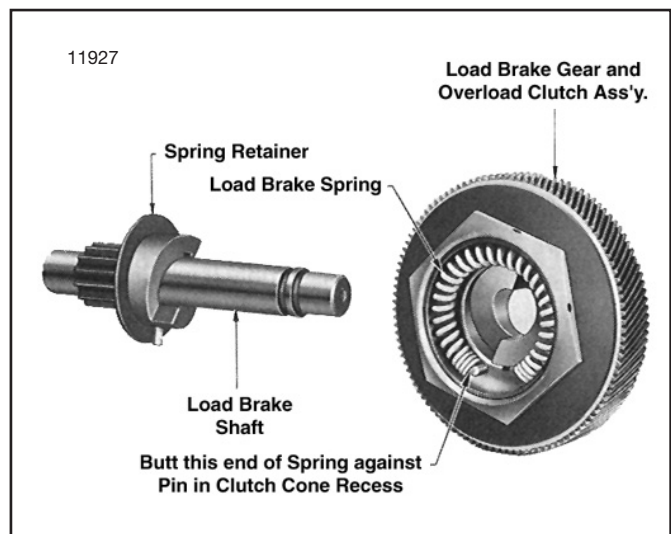

Figure 7-24. Load Brake Gear and Overload Clutch Assembly Removed from Load Brake Shaft Showing Brake Spring Installed in Clutch Cone

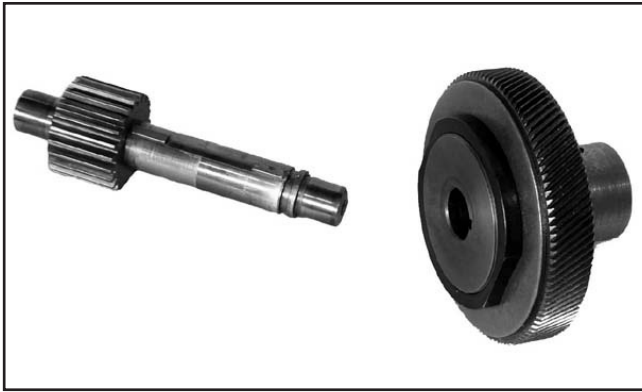

Figure 7-24a.

(4) The load brake pawl and ratchet is a riveted assembly and is not to be disassembled.

**b. Reassembly.**

(1) Before assembly, all parts should be cleaned and inspected to determine their serviceability. Replace parts that are worn or damaged.

(2) Reassemble load brake parts following a reverse procedure of the disassembly steps listed above, observing the assembly steps (3) through (6) below.

(3) Before installing spring in its recess in center of clutch cone (fig. 7-24) apply a good grade of ball bearing grease to inside of recess. Spring must be positioned exactly as illustrated, abutted against pin.

(4) When installing pawl and ratchet assembly on load brake shaft, be certain that teeth on ratchet face are in the same direction as shown in fig. 7-23. The ratchet assembly should rotate freely when turned counterclockwise and the pawl should engage ratchet teeth when unit is turned clockwise.

(5) When installing brake flange position it with chamfer facing friction disc, figure 7-22.

(6) The brake spring must be pre-loaded at assembly to a torque of from 6 to 10 lb. ft. when used with yellow (color code) spring and a torque of 10 to 14 lb. ft. when used with plain (no color code) spring. (See Section IX for proper spring). This is accomplished using a plumber's strap wrench to wind (rotate) load brake gear to set up spring (fig. 7-25) while pressing brake flange into place using an arbor press. Clamp pinion end of shaft into a portable vice to keep brake from rotating in press. Use brass or copper jaw plates on vise to protect pinion gear teeth. Wind gear counterclockwise (viewing brake from flange end) with strap wrench and press down on flange until snap ring groove in shaft is exposed allowing snap ring to be installed. Use extreme care not to over wind spring as yield will result and final spring torque will be reduced. Do not wind gear beyond point necessary to install snap ring in groove.

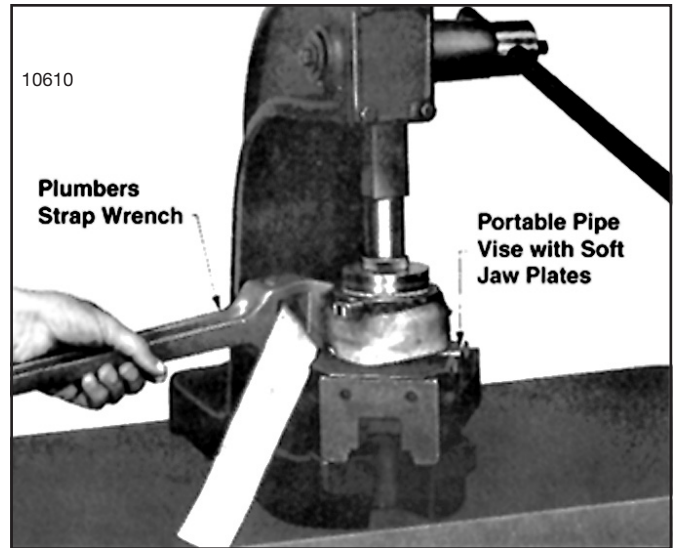

Figure 7-25. Winding Load Brake Gear Using a Strap Wrench to Set Up Load Brake Spring

**7-1A. OVERLOAD CLUTCH WITHOUT LOAD BRAKE.**

Disassembly of the clutch gear and overload clutch assembly (fig 7-24a) is not recommended. Clutch pressure is preset at the factory at assembly to provide the correct torque to allow the clutch to refuse loads within a specified range (150% of rated load to 200% rated load). It is suggested whenever there is a need to repair or readjust the overload clutch assembly that it be sent to an authorized CM Hoist Repair Station where adequate tools, fixtures, and appropriate test equipment is available.

## 7-2. Air Gap Adjustment

Brake air gaps are factory adjusted to .100". As friction discs wear the air gap will increase. When the gap reaches .200" it will need to be readjusted to .100".

1. Loosen jam nut (10N).
2. Turn adjusting screw (10) CW until .100" gap is reached (see Fig. 1).
3. Retighten jamb nut.
4. Check air gap again.

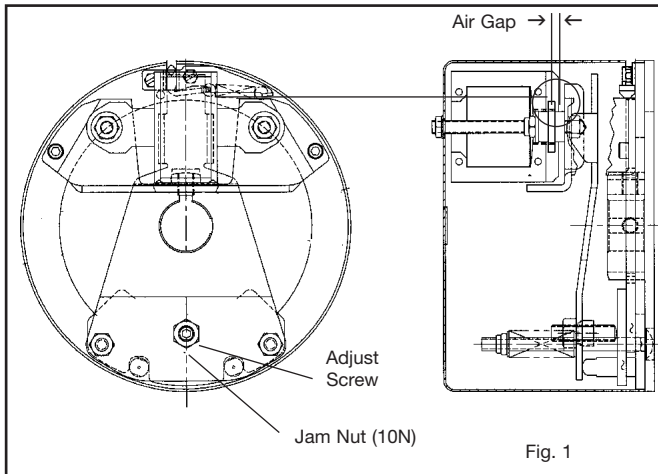

## Torque Adjustment

The brake is factory set for nominal rated torque. No further adjustment to increase torque may be made. The approximate compressed torque spring height is shown below. Torque reduction may not exceed 1 full turn in the CCW direction (1.5 lb-ft brake cannot be reduced). Note that the spring measurement for the 6 lb-ft spring is from inside the shoulder washer.

Brake Torque (lb-ft)	Length "L" (in.)	Max Torque Reduction (ccw turn of torque nut)	% Reduction
1.5	1.102	0	0
3	.954	1	15
6	1.286	1	25

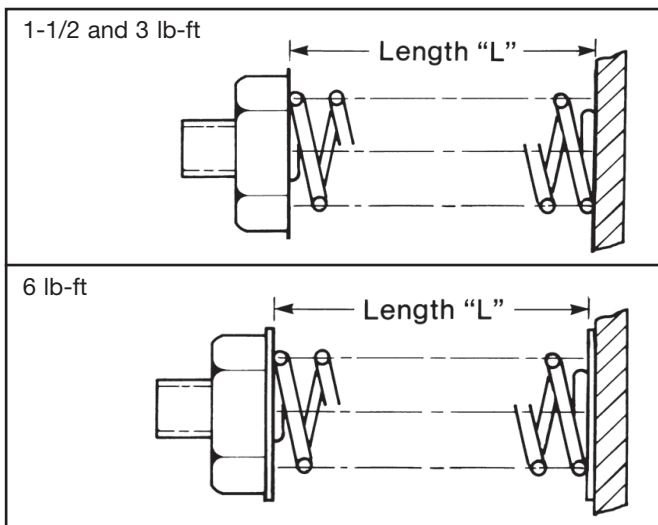

## Friction Disc Replacement

Friction disc(s) should be replaced when the wear area is 3/32" thick or less.

1. Remove the two brake mounting screws and lift the brake assembly from the hub / motor.
2. Remove the two support bracket screws (35), and lift the brake and solenoid assembly (3) off the brake.
3. Lift the lever arm (17) forward and slide the friction disc(s) out of the brake assembly.
4. Insert new friction disc(s) under the stationary disc (5). If brake has two friction discs align the center spline holes with each other.
5. Align the brake and friction disc assembly on the hub (16) and slide onto the motor. Insert and tighten the two brake mounting screws (15-20 lb-ft).
6. Reposition the support bracket assembly (3) on the brake, and retighten the two support bracket screws (35), (52 lb-in).

**Note:** Air gap readjustment will be required after disc replacement.

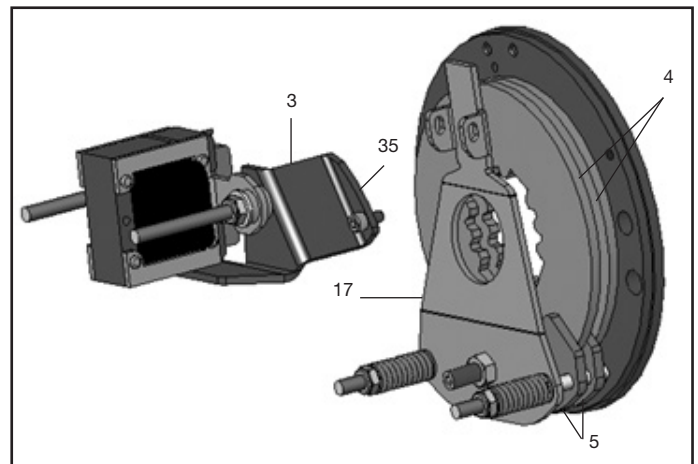

## Coil Replacement

1. Remove the two support bracket screws (35), and lift the bracket and solenoid assembly (3) off the brake.
2. Remove the plunger guide (140) from the inside of the coil.
3. Remove the thru-bolt (160) from the leadwire side of the coil by backing off the lock-nut (210). Slide the bolt, shock mount pads and flat washer out of the way.
4. Remove the coil (12) from the solenoid frame (79) by pushing down on the coil locking tab on the side opposite the leadwires. Push the coil out of the frame.
5. Insert the new coil into the solenoid frame in reverse of the steps of removal. Insert the new plunger guide (140) into the coil, locking tabs first.
6. Position a shock mount pad (150) on both sides of the solenoid mounting bracket, and reinsert the thru-bolt (160) through the shock pads and bracket.
7. Slide a flat washer (170) over the bolt, and tighten the locknut down until the shock pads begin to flatten.



8. Position the solenoid and bracket assembly (3) over the plunger (29) and slide into place. Tighten the bracket mounting screws (35) to 52 in-lb.
9. Reassemble brake motor by following steps 5-7 of the brake mounting procedure.

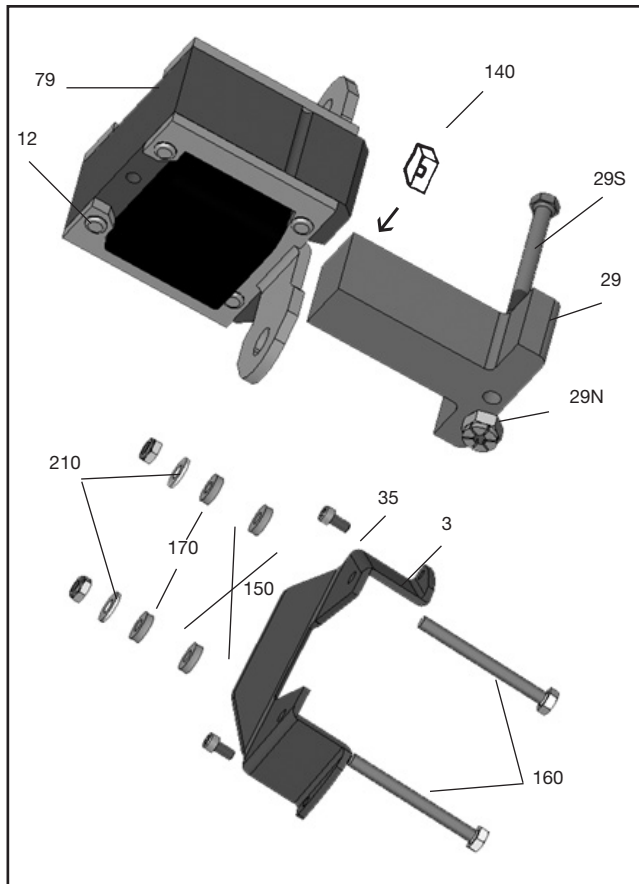

### Solenoid Replacement

1. Remove the two support bracket screws (35), and lift the bracket assembly (3) off the brake.
2. Remove the plunger guide (140) from the inside of the coil.
3. Remove both thru-bolts (160) from the solenoid assembly (79).
4. Remove the coil (12) from the solenoid frame (79) by pushing down on the coil locking tab on the side opposite the leadwires. Push the coil out of the frame.
5. Insert the coil into the new solenoid frame in reverse of the steps of removal. Insert the new plunger guide (140) into the coil, locking tab first.
6. Position the new shock mount pad (150) on both sides of the solenoid mounting bracket, and reinsert the tap-bolts (160) through the shock pads and bracket.
7. Slide the flat washers (170) over the bolt, and tighten the locknut down until the shock pads begin to flatten.
8. Remove the plunger nut (29N) and screw (29S), and lift plunger (29) from lever arm (17). Install the new plunger to the lever arm using the new screw and nut provided. Tighten to 40 in-lb.

9. Position the solenoid and bracket assembly (3) over the plunger (29) and slide into place. Tighten the bracket mounting screws (35) to 50 in-lb.
10. Reassemble brake to motor by following steps 4-7 of the brake mounting procedure.

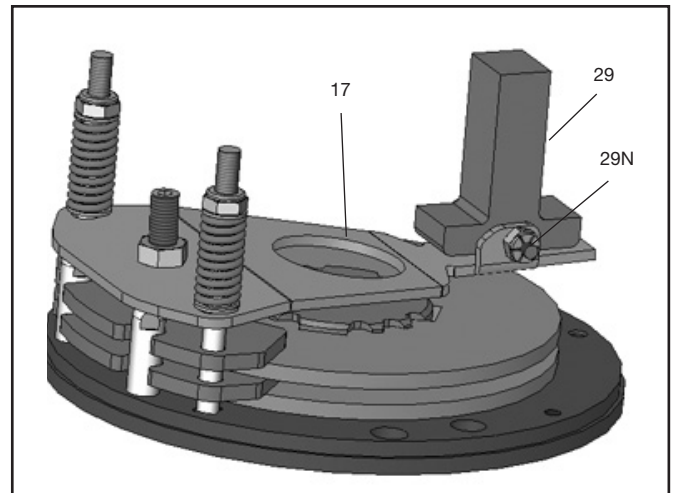

### Two Piece Chain Stop

Chain Size	Number of Chain Links From End
1/4" Wire Dia.	12 Links (9½")
5/16" Wire Dia.	10 Links (9")

### Paddle Limit Switch

1/4" Wire Dia.	8 Links
5/16" Wire Dia.	8 Links

### Wiring Hook-Up

Before installing hoist, connect wiring to electrical controls in accordance with applicable wiring diagram. Wires are coded and/or numbered to agree with wiring diagrams.

TROUBLESHOOTING			
<b>Coil Failure</b>		<b>Excessive Wear/Overheating</b>	
<b>Supply Voltage Cause</b>	<b>Supply Voltage Correction</b>	<b>Air Gap Cause</b>	<b>Air Gap Correction</b>
Line voltage >110% of coil rating	Reduce voltage or replace with proper rated coil	Low solenoid air gap	Reset air gap (refer to Air Gap Adjustment)
Excessive voltage drop during inrush time	Increase current rating of power supply	<b>Cycle Rate Cause</b>	<b>Cycle Rate Correction</b>
<b>Wiring Cause</b>	<b>Wiring Correction</b>	Brake "jogging" exceeding coil cycle rate	Reduce cycle rate or consider alternate control method
Leadwires interfering with plunger pull-in	Reroute wiring away from plunger and other moving components	Thermal capacity is being exceeded	Reduce cycle rate, use alternate control method or increase brake size
Coil leadwire shorted to ground	Replace coil or leadwire and protect with wire sleeving	<b>Alignment Cause</b>	<b>Alignment Correction</b>
<b>Solenoid Assembly Cause</b>	<b>Solenoid Assembly Correction</b>	Brake endplate not concentric to motor C-Face	Motor resister must be within .004" on concentricity
Plunger not seating flush against solenoid frame	Loosen solenoid mounting nuts and reposition frame to allow full face contact	Motor shaft runout is excessive	Must be within .002"; runout; consult motor manufacturer
Excessive solenoid/plunger wear at mating surface	Replace solenoid assembly	<b>Worn Parts Cause</b>	<b>Worn Parts Correction</b>
Broken shading coils	Replace solenoid assembly	Friction disc excessively worn (disc can wear to 1/2 original thickness or .093")	Replace friction discs
<b>Worn Parts Cause</b>	<b>Worn Parts Correction</b>	Endplate, stationary disc or pressure plate warped	Replaced warped or worn component
Excessive wear of solenoid link bolt	Replace link bolt; also inspect plunger thru-hole for elongation	Linkages worn	Replace all worn components
Plunger guide worn down and interfering with plunger movement	Replace guide	Motor shaft endfloat excessive	Endfloat must not exceed .020"; consult motor manufacturer
<b>Application Cause</b>	<b>Application Correction</b>	<b>Hub Cause</b>	<b>Hub Correction</b>
Machinery cycle rate is exceeding brake rating	Reduce brake cycle rate or use alternate control method	Burr on hub interfering with disc "float"	File off burr
High ambient temperature (>110° F) and thermal load exceeding coil insulation rating	Use Class H rated coil and/ or find alternate method of cooling brake	Set screw backed out and interfering with disc	Retighten set screw; use Loctite® 680 to help secure
Brake coil wired with windings of an inverter motor or other voltage/current limiting device	Wire coil to dedicated power source with instantaneous coil rated voltage	<b>Miscellaneous</b>	<b>Miscellaneous</b>
<b>Miscellaneous Cause</b>	<b>Miscellaneous Correction</b>	Wiring is restricting disc pack movement	Reroute wiring
Wrong or over tightened torque springs	Replace with proper spring or refer to installation section for proper spring height	Excessive stop time (2 seconds or greater)	Increase brake size/torque or use alternate control method
Excessive air gap	Reset, refer to Airgap Adjustment	High Ambient temperature (in excess of 110°F)	Reduce cycle rate or use alternate method of cooling

### 7-3. TESTING HOIST.

a. **General.** After completion of reassembly and before placing hoist in service, hoist should be tested to insure safe operation. To test: suspend hoist from an overhead supporting member of sufficient strength to carry twice rated load; connect to a power supply of the specified voltage (see data plate attached to motor); and perform the following checks and adjustments.

b. **Check For Correct Control Operation.** Refer to Section II, paragraph 2-4. d, under "Warning."

c. **Check Upper and Lower Limit Stop Operation (paddle limit).** To determine if upper and lower limit stop functions properly, make the following checks while operating hoist with push button control and actuating the limit lever by hand:

(1) Depress "↑" push button and with chain running in raise direction, pull down on end of limit lever at tail chain side of hoist (left side facing cover end). The "UP" limit switch should cut off power, causing the hoist to stop.

(2) Depress "↓" push button and with chain running in lowering direction, push up on same end of limit lever. The "DOWN" limit switch should cut off power, causing the hoist to stop.

(3) If hoist does not stop in both travel directions, check for improper wiring. Refer to par. 6-2 and appropriate wiring diagram. If wiring is correct, check to see that limit switch is correctly installed.

(4) As a final check, operate hoist (no load) in the lowering direction and allow tail chain limit actuator to trip limit lever.

Hook should stop. Repeat check in hoisting direction and allow lower block to trip limit lever. Hook should stop.

e. **Check Hoist With Rated Load.** Attach rated load to lower hook and check hoist operation. If hoist does not lift rated load, refer to par. 7-13.

(1) Operate hoist to raise load. When control is released, hoist should instantaneously stop and hold load at that level.

(2) Operate hoist to lower load a short distance, then release control. Hoist should stop instantaneously and hold load at that level.

(3) If hoist does not stop or hold load refer to Section VI.

### 7-13. TEST PROCEDURE FOR CHECKING OPERATION OF OVERLOAD CLUTCH.

a. **General.** The overload clutch must be tested using known weights. The following prerequisites (par. (1) through (4)) must be strictly observed in performing this test.

(1) A qualified person shall determine before testing, that all structures supporting the hoist are adequately strong to withstand the test load of 200 percent of rated hoist load, whether hoist is tested in installed position or moved to a designated test facility.

(2) Loads used for testing must be accurately known.

(3) Test shall be made only by a qualified operator thoroughly familiar with the hoist and the purpose of the test.

(4) Provide adequate and proper rigging to insure test loads are securely attached, properly balanced, and will lift level.

b. **Test Procedure.** With the above prerequisites satisfied and hoist properly connected to electrical power, proceed with the test as follows:

(1) Using a known load equal to rated load of hoist, operate hoist to lift load. Raise load high enough to be certain the entire load is freely suspended. **Clutch should not slip at rated load.** If hoist does not lift rated load, clutch requires adjustment. Refer to Section V, par. 5-4. c.

(2) Increase load to 200 percent rated load and operate hoist to lift the load. **Clutch must slip**, causing the hoist to refuse to lift the load. If hoist lifts this overload, the overload clutch is out-of-adjustment and must be readjusted. Refer to Section V, par. 5-4. c.

(3) If clutch slips as required in step (2) above, continue to run hoist (clutch slipping-hoist refusing to lift load) for five (5) cycles of one (1) second each.

(4) Remove excess weight to return the load to rated hoist load. Lift rated load one final time to be certain that the clutch does not slip and that the hoist lifts the rated load.

## **WARNING**

**DO NOT LIFT MORE THAN RATED LOAD EXCEPT FOR TEST PURPOSES**

### **NOTICE**

**THIS EQUIPMENT MUST BE EFFECTIVELY GROUNDED ACCORDING TO THE NATIONAL ELECTRIC CODE, ARTICLE 250, 610-61 AND OTHER APPLICABLE CODES.**

## SECTION IX - REPLACEMENT PARTS

This section contains complete replacement parts information for your new **CM Man Guard™** Electric Hoist. The parts are grouped and illustrated in exploded view photos to permit easy identification. Each part in an illustration is keyed by reference number to a corresponding parts table. In the table will be found the part number, description and quantity required.

**NOTICE:** Information herein is subject to change without notice. Parts must be ordered from an Authorized **CM** Repair Station or from a **CM** Hoist Distributor.

When ordering replacement parts it will be necessary that you include, with your order, the part number of parts required, plus, hoist catalog number and model number, which will be found on the hoist nameplate attached to hoist. For motors, complete motor nameplate data is required. Complete inspection, maintenance and overhaul service is available for **CM Man Guard™** Electric Hoists at any of the Authorized Repair Stations. All are staffed by qualified factory-trained servicemen; have authorized testing equipment; and stock a complete inventory of genuine replacement parts.

**The numbers assigned to the parts of our various assemblies in our parts lists are not the part numbers used in manufacturing the part. They are identification numbers, that when given with the hoist serial number, permit us to identify, select or manufacture, and ship the correct part needed for any hoist.**

### INDEX OF EXPLODED VIEW PARTS ILLUSTRATIONS

Figure No.	Title	Page
9-1	Overview .....	20
9-2a	Upper Suspensions 1/4 to 1 Ton Hook.....	21
9-2b	Upper Suspensions 1/4 to 1 Ton Lug .....	22
9-2c	Upper Suspensions 2 Ton Hook.....	23
9-2d	Upper Suspensions 2 Ton Lug .....	24
9-2e	Upper Suspensions 3 Ton Hook.....	25
9-2f	Upper Suspensions 3 Ton Lug .....	26
9-3a	Lower Hook Block Assembly 1/4 to 1 Ton.....	27
9-3b	Lower Hook Block Assembly 2 Ton .....	28
9-3c	Lower Hook Block Assembly 3 Ton .....	29
9-4	Gearcase Assembly .....	30-31
9-5a	Controls and Single Speed Single Phase .....	32
9-5b	Controls and Variable Speed Three Phase.....	33
9-5c	Controls and Variable Speed Three Phase.....	34
9-6	Brakes.....	35
9-7	Motors.....	35
9-8	Limit Switch Assembly with Stops and Chain .....	36
	Wiring Diagrams .....	37
9-9a	115V-1PH-60Hz Single Speed Units only .....	37
9-9b	230V-3PH-60Hz Single Speed Units only .....	38
9-9c	230V-3PH-69Hz or 460V-3PH-60Hz Infinitely Variable Frequency Drive Units only .....	39
9-9d	Convert from 115V-1PH-60Hz to 230V-1PH-60Hz .....	40
9-9e	Convert from 230V-3PH-60Hz to 460V-3PH-60Hz .....	41
9-10	Pendants and Cables .....	42
9-11	Chain Containers HDPE .....	43

To enable us to expedite your parts order, always give Model and Catalog Number and Electric Current of Hoist. (See nameplate.)

## 1/4 TO 1 TON WITH LIMITED ROTATION UPPER HOOK SUSPENSION

ITEM NO.	PART NUMBER	DESCRIPTION	QTY.
1	11819702	"L" KEEPER	1
2	10392022	SHCS 1/4-20 X 3/4	3
3	10095701	1/4 LOCK WASHER	3
4	22736928	LIMITED ROTATION UPPER HOOK SUSPENSION	1
5	11824301	ANTI-ROTATION BRACKET	1

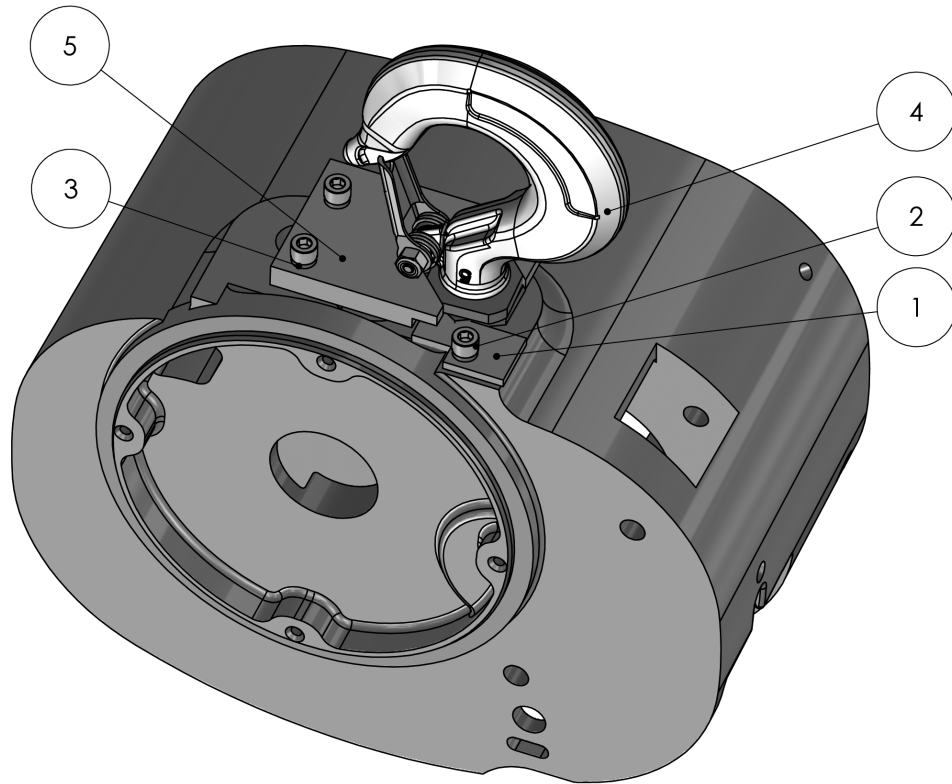

Figure 9-2A. UPPER SUSPENSION, 1/4 TO 1 TON HOOK

# 1/4 TO 1 TON LUG SUSPENSIONS

ITEM NO.	PART NUMBER	DESCRIPTION	QTY.
1	23456903	1 TON LUG SUSPENSION ASSEMBLY	1
2	11824301	ANTI-ROTATION BRACKET	1
3	10392022	SHCS 1/4-20 X 3/4	3
4	10095701	1/4 LOCK WASHER	3
5	11819702	"L" KEEPER	1

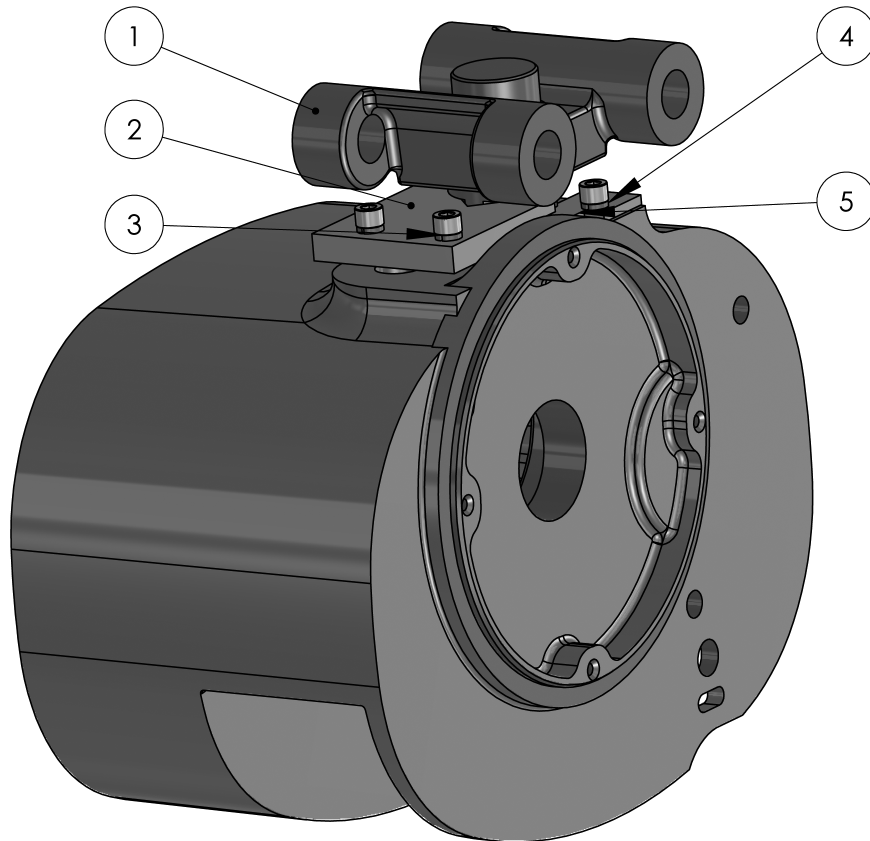
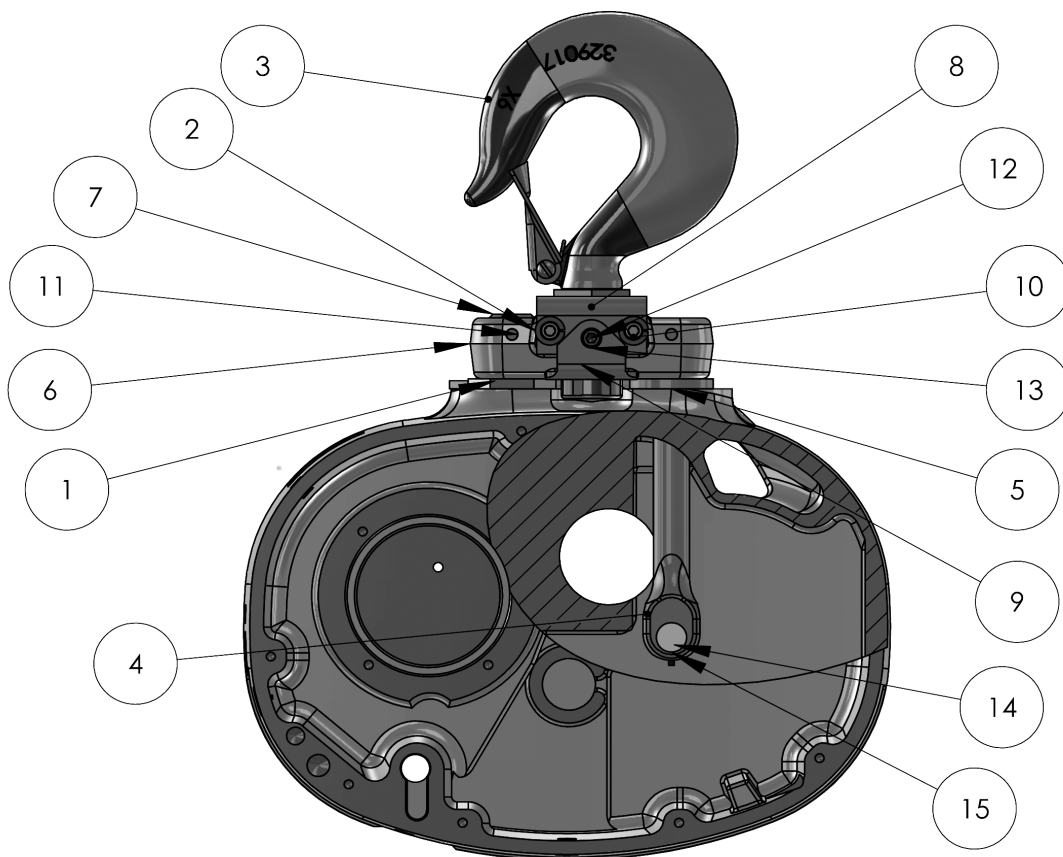

Figure 9-2B. UPPER SUSPENSION, 1/4 TO 1 TON HOOK

To enable us to expedite your parts order, always give Model and Catalog Number and Electric Current of Hoist. (See nameplate.)

## 2 TON RIGID HOOK SUSPENSIONS



ITEM NO.	PART NUMBER	DESCRIPTION	QTY.
1	11819702	"L" KEEPER	1
2	10095701	LOCK WASHERS	3
3	21648701	2 TON UPPER HOOK ASSEMBLY	1
4	21556205	LINK CHAIN ANCHOR	1
5	11820001	SPACER WASHER	1
6	21556301	HOOK ADAPTER	1
7	11820102	LUG SUSPENSION STUD	1
8	10764501	BUSHING LOCK	1
9	10764801	LOCK PLATE	1
10	NO14	SHCS #10-24 1/2	2
11	10763901	PIN GROOVED STRAIGHT F	2
12	10381011	SHCS #10-24 5/16	1
13	10404510	LOCK WASHERS	1
14	10036205	COTTER PIN	1
15	10731901	PIN 3/8 DIA X 1 7/8	1

Figure 9-2C. UPPER SUSPENSION, 2 TON HOOK

## 2 TON LUG SUSPENSIONS

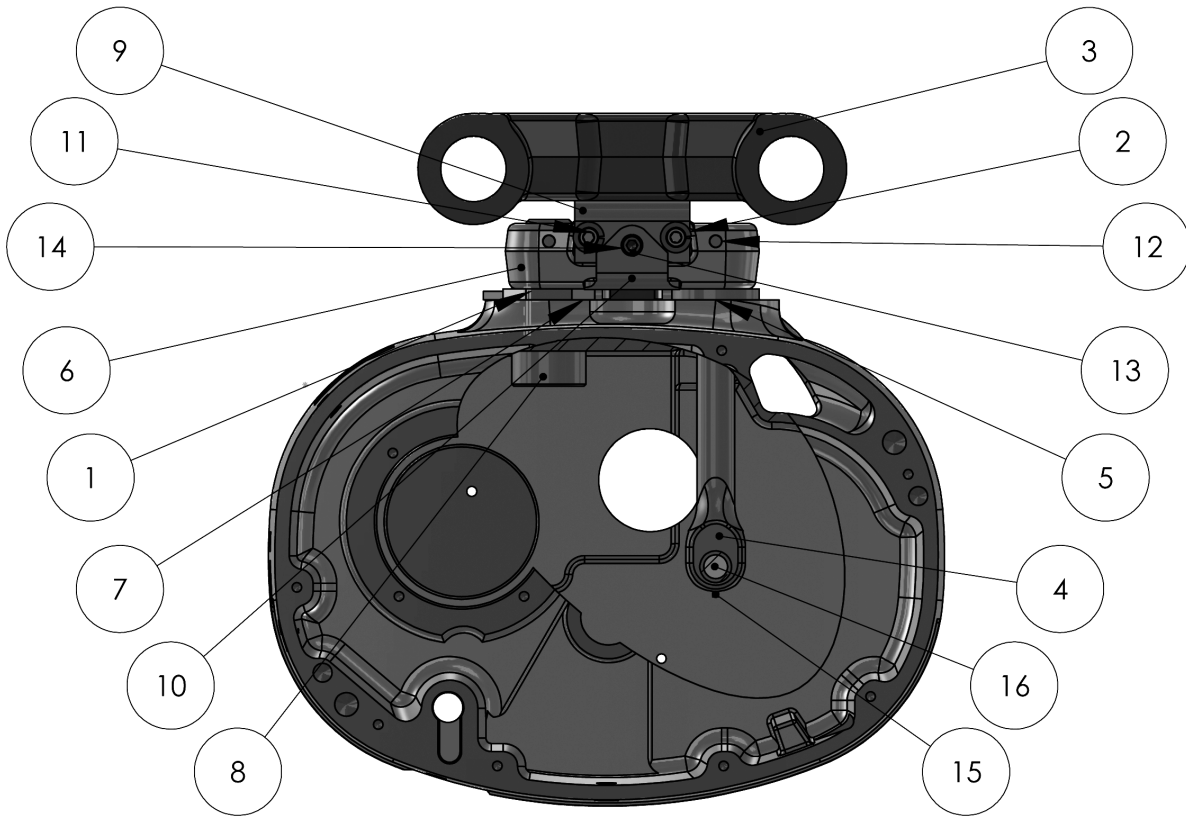

ITEM NO.	PART NUMBER	DESCRIPTION	QTY.
1	11819702	"L" KEEPER	1
2	10095701	LOCK WASHER	3
3	31239201	2 TON SUSPENSION BRACKET	1
4	21556205	LINK CHAIN ANCHOR	1
5	11820001	SPACER WASHER	1
6	21556301	LUG/HOOK ADAPTER	1
7	10764301	BUSHING	1
8	11820102	LUG SUSPENSION STUD	1
9	10764501	BUSHING LOCK	1
10	10764801	LOCK PLATE	1
11	NO14	SHCS # 10-24 1/2	2
12	10763901	PIN GROOVED STRAIGHT F	2
13	10381011	SHCS #10-24 X 5/16	1
14	10404510	LOCK WASHER	1
15	10036205	COTTER PIN	1
16	10731901	PIN 3/8 DIA X 1 7/8	1

Figure 9-2D. UPPER SUSPENSION, 2 TON LUG



To enable us to expedite your parts order, always give Model and Catalog Number and Electric Current of Hoist. (See nameplate.)

### 3 TON UPPER LIMITED ROTATION HOOK SUSPENSION

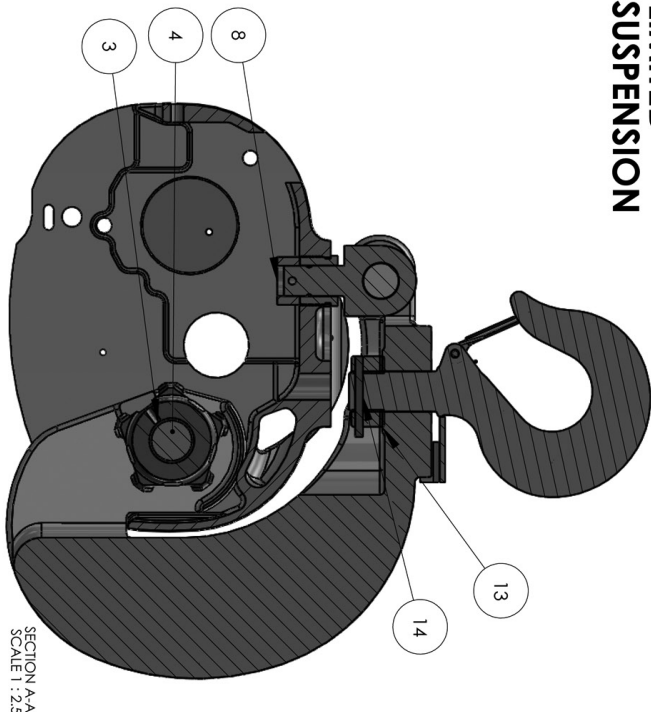
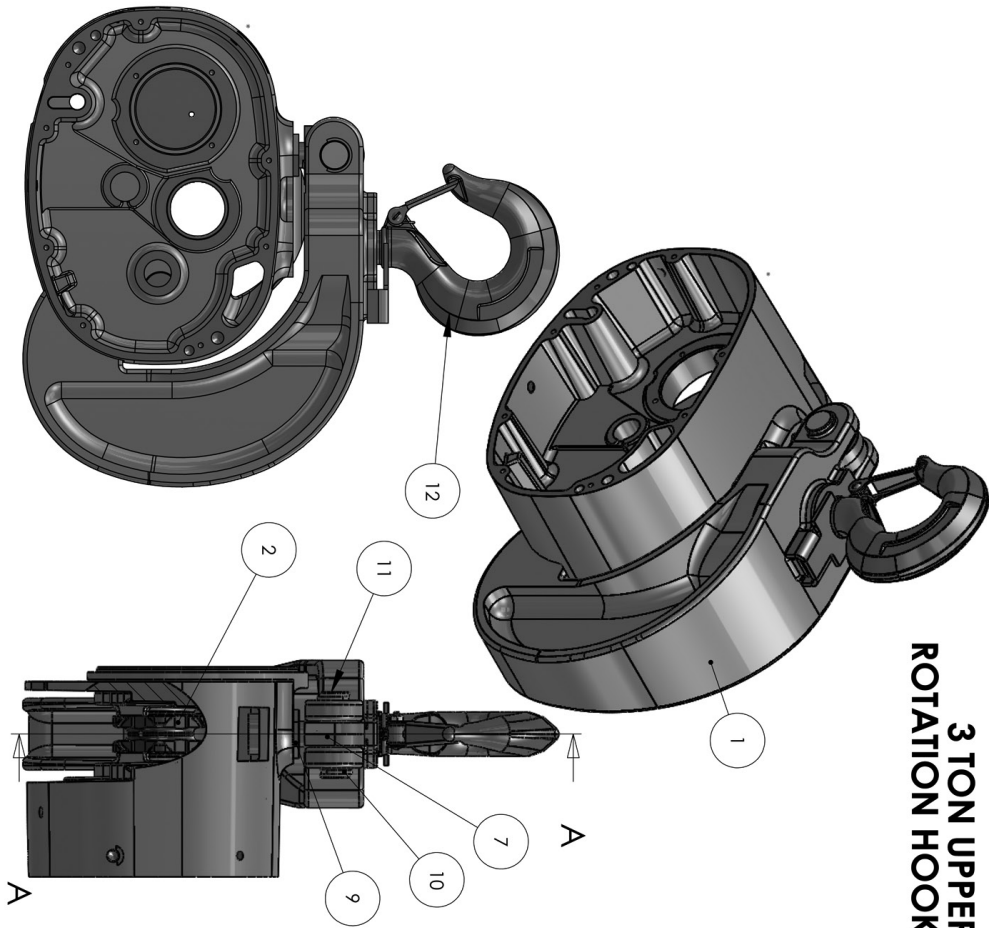

SECTION A-A  
SCALE 1 : 2.5

ITEM NO.	PART NUMBER	DESCRIPTION	QTY.
1	42863003	HANGER BRACKET 3 TON	1
2	21556502	SPROCKET	1
3	10614101	BUSHING DU	2
4	11273002	PIN IDLER SPROCKET	1
5	10171682	PIN ROLL SLOTTED SPRING (NOT SHOWN)	1
6	10346106	WASHER FLAT	2
7	11272602	CONNECTING ROD	1
8	11565401	ROUND NUT	1
9	10764301	HEX BUSHING	1
10	NO8106	RETAINING RING EXTERNAL OPEN	2
11	11272801	CONNECTING PIN HANGER	1
12	22502901	LIMITED ROTATION HOOK AND NUT ASSEM.	1
13	10816508	BEARING THRUST WASHER DU	1
14	10099658	PIN GROOVED STRAIGHT A	1

Figure 9-2E. UPPER SUSPENSION, 3 TON HOOK

To enable us to expedite your parts order, always give Model and Catalog Number and Electric Current of Hoist. (See nameplate.)

### 3 TON UPPER LUG SUSPENSION

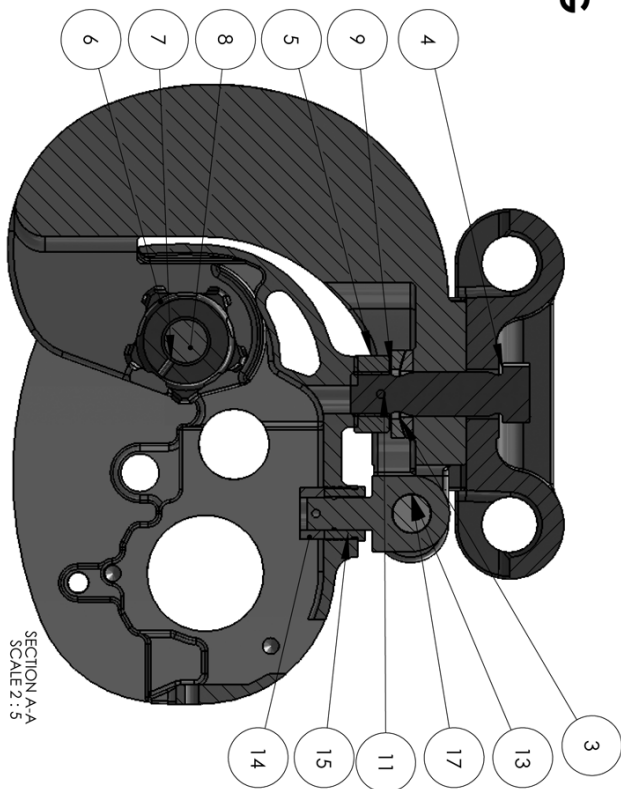
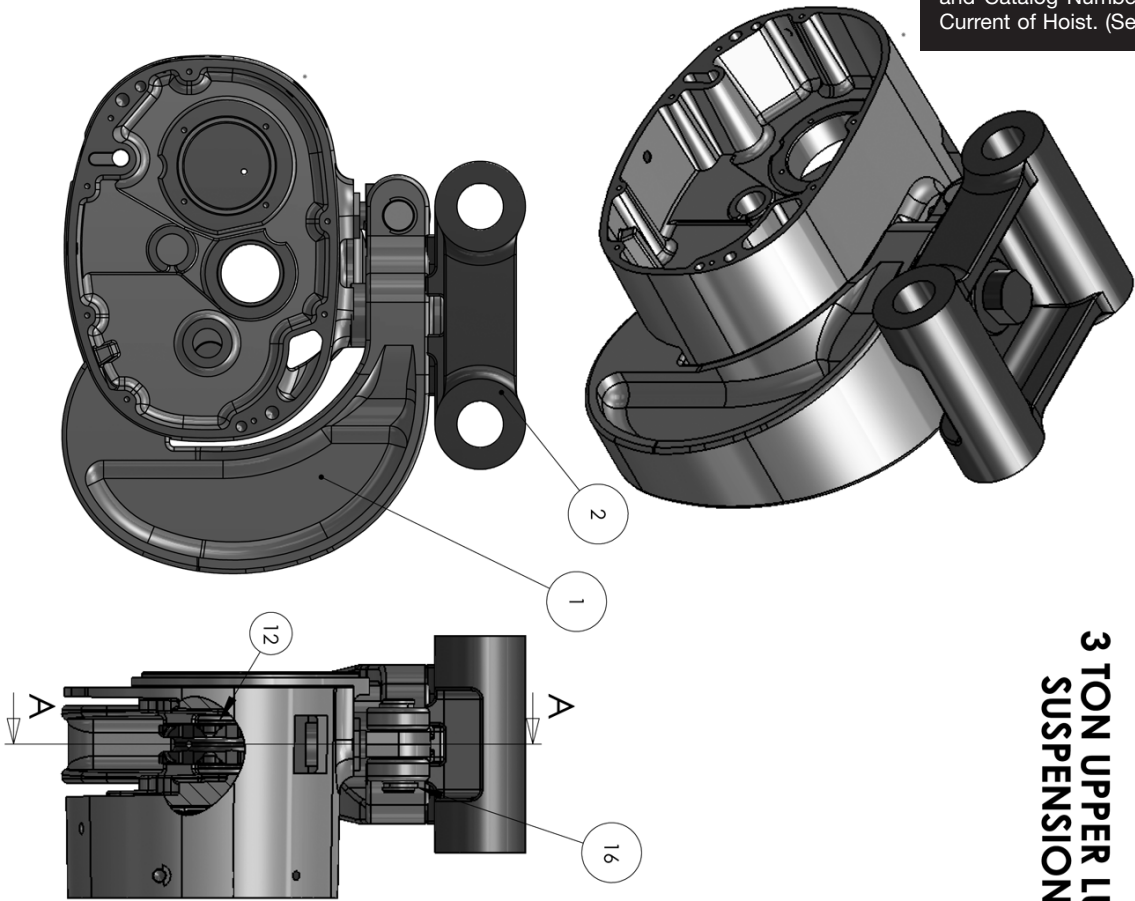

SECTION A-A  
SCALE 2:5

ITEM NO.	PART NUMBER	DESCRIPTION	QTY.
1	42863003	HANGER BRACKET 3 TON	1
2	42863102	TROLLEY ADAPTER LUG	1
3	11275001	WASHER SPHERICAL	1
4	11272701	SUSPENSION PIN	1
5	22429803	NUT ROUND 1-12	1
6	21556502	SPROCKET	1
7	10614101	BUSHING DU	2
8	11273002	PIN IDLER SPROCKET	1
9	10231001	WASHER FLAT	1
10	10171682	PIN ROLL SLOTTED SPRING (NOT SHOWN)	1
11	10099658	PIN GROOVED STRAIGHT A	1
12	10346106	WASHER FLAT	2
13	11272602	CONNECTING ROD	1
14	11565401	ROUND NUT	1
15	10764301	HEX BUSHING	1
16	NO8106	RETAINING RING EXTERNAL OPEN	2
17	11272801	CONNECTING PIN HANGER	1

Figure 9-2F. UPPER SUSPENSION, 3 TON LUG

# 1/4 TO 1 TON LOWER BLOCK ASSEMBLY

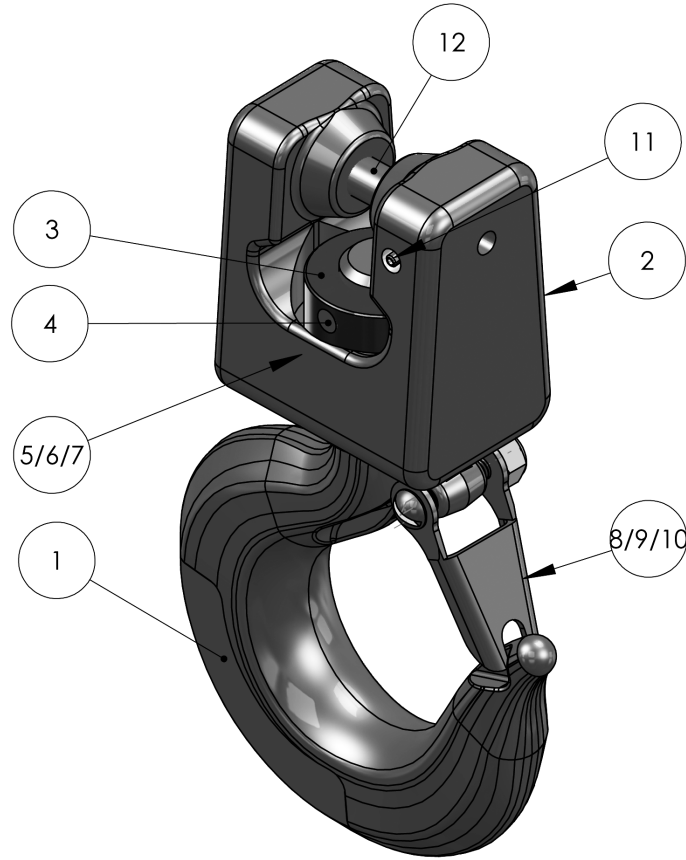

ITEM NO.	1/4 TON CODES	1/2 TON CODES	1 TON CODES	DESCRIPTION	QTY.
1	22505001	22505001	22505001	Size 4 Carbon Steel Hook W/LATCH	1
2	3262170	32621702	32621702	LOWER HOOK BLOCK	1
3	11008401	11008401	11008401	HOOK NUT 5/8-18 THD	1
4	10763901	10763901	10763901	GROOVE PIN	1
5/6/7	21655805	21655805	21655805	BEARING SHIELD (UNDER ITEM 2)	1
6	10409107	10409107	10409107	NEEDLE THRUST BEARING	1
7	10436010	10436010	10436010	THRUST WASHER	1
8/9/10	4X1304LT	4X1304LT	4X1304LT	LATCH KIT	1
11	10171640	10171640	10171640	SPRING PIN, 3-32 X .75IN	1
12	10686501	10686501	10686501	LOWER BLOCK PIN	1

Figure 9-3G. LOWER HOOK BLOCK ASSEMBLY 1/4 TO 1 TON

To enable us to expedite your parts order, always give Model and Catalog Number and Electric Current of Hoist. (See nameplate.)

## TWO TON LOWER HOOK BLOCK ASSEMBLY

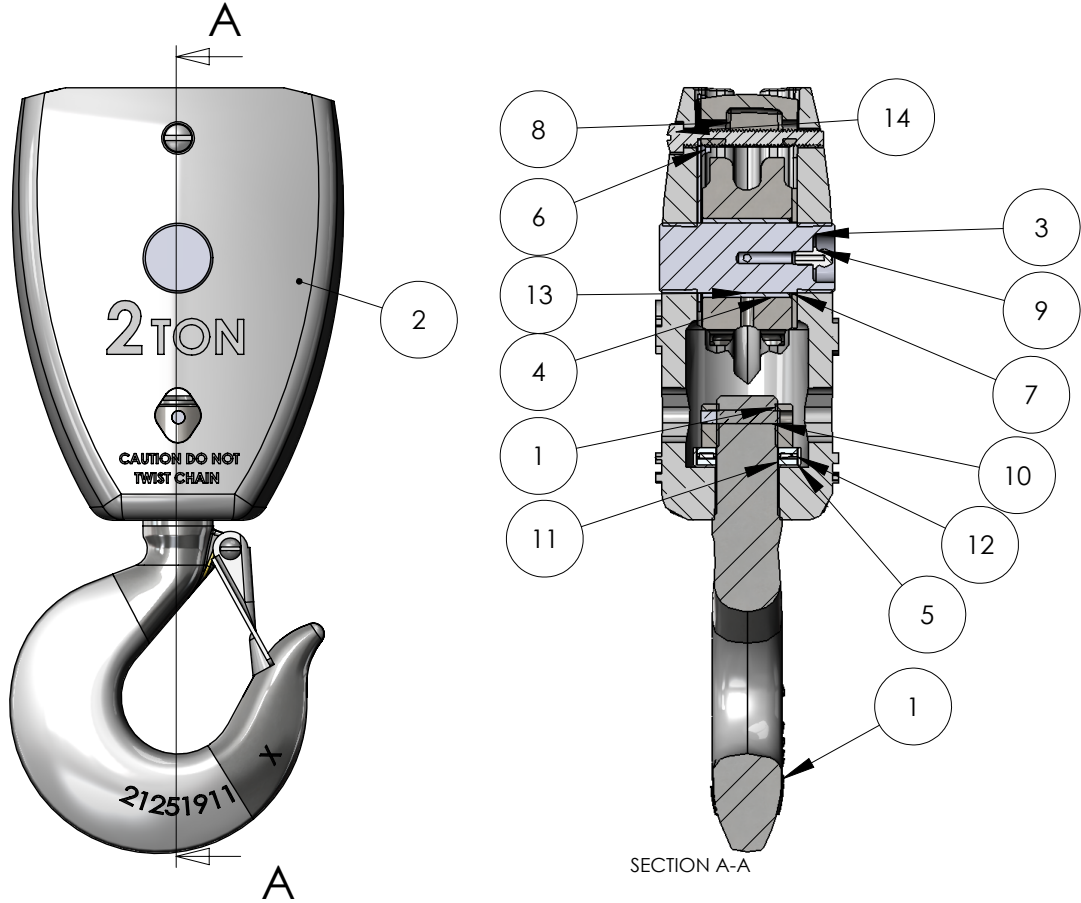

ITEM NO.	PART NUMBER	DESCRIPTION	QTY.
1	21251901	HOOK AND NUT ASSEMBLY	1
2	21556601	LOWER BLOCK BODY 2 TON	1
3	10732101	PIN" DIA 2 1/2" LG.	1
4	21556501	SPROCKET	1
5	21655803	SHIELD	1
6	10732201	LOCK PIN	1
7	10346106	WASHER FLAT	1
8	21556701	CENTER GUIDE	1
9	NO6099	LUBRICATION FITTING 3/16" DRIVE	1
10	10763901	PIN GROOVED STRAIGHT F	1
11	10436012	BEARING THRUST WASHER	2
12	10409104	BEARING NEEDLE THRUST	1
13	10755701	BUSHING	1
14	10694301	SCREW FILLISTER HEAD SLOTTED	1

Figure 9-3H. LOWER HOOK BLOCK ASSEMBLY 2 TON

## 3 TON LOWER BLOCK ASSEMBLY

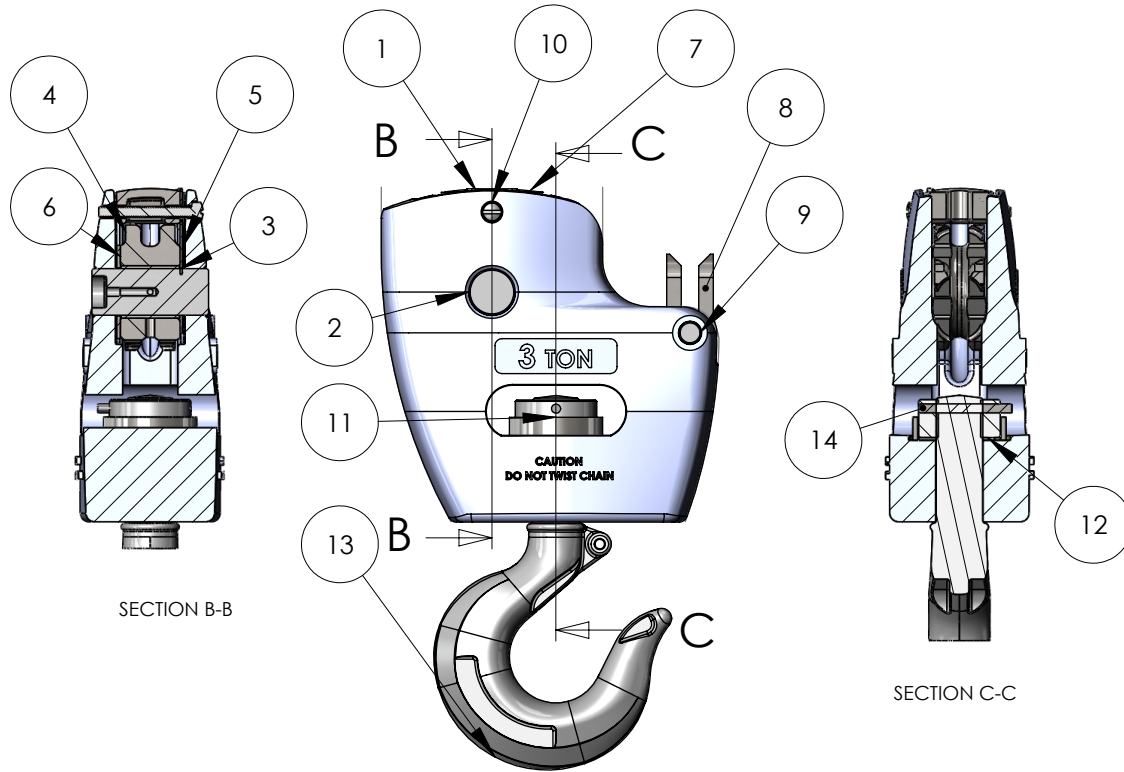

ITEM NO.	PART NUMBER	DESCRIPTION	QTY.
1	32584401	3 TON HOOK BLOCK	1
2	10732101	PIN	1
3	10755701	BUSHING DU	1
4	21556501	HOOK BLOCK SPROCKET	1
5	10732201	LOCK PIN	1
6	10346106	WASHER FLAT	1
7	21556701	CENTER GUIDE	1
8	11272901	CONNECTING LINK	1
9	10770002	PIN DOWEL	1
10	10694301	SCREW	1
11	11248301	SHROUD	1
12	10816508	BEARING THRUST WASHER	1
13	22459401	HOOK AND NUT ASSEMBLY	1
14	10099658	PIN	1

**Figure 9-3I. LOWER HOOK BLOCK ASSEMBLY 3 TON**

To enable us to expedite your parts order, always give Model and Catalog Number and Electric Current of Hoist. (See nameplate.)

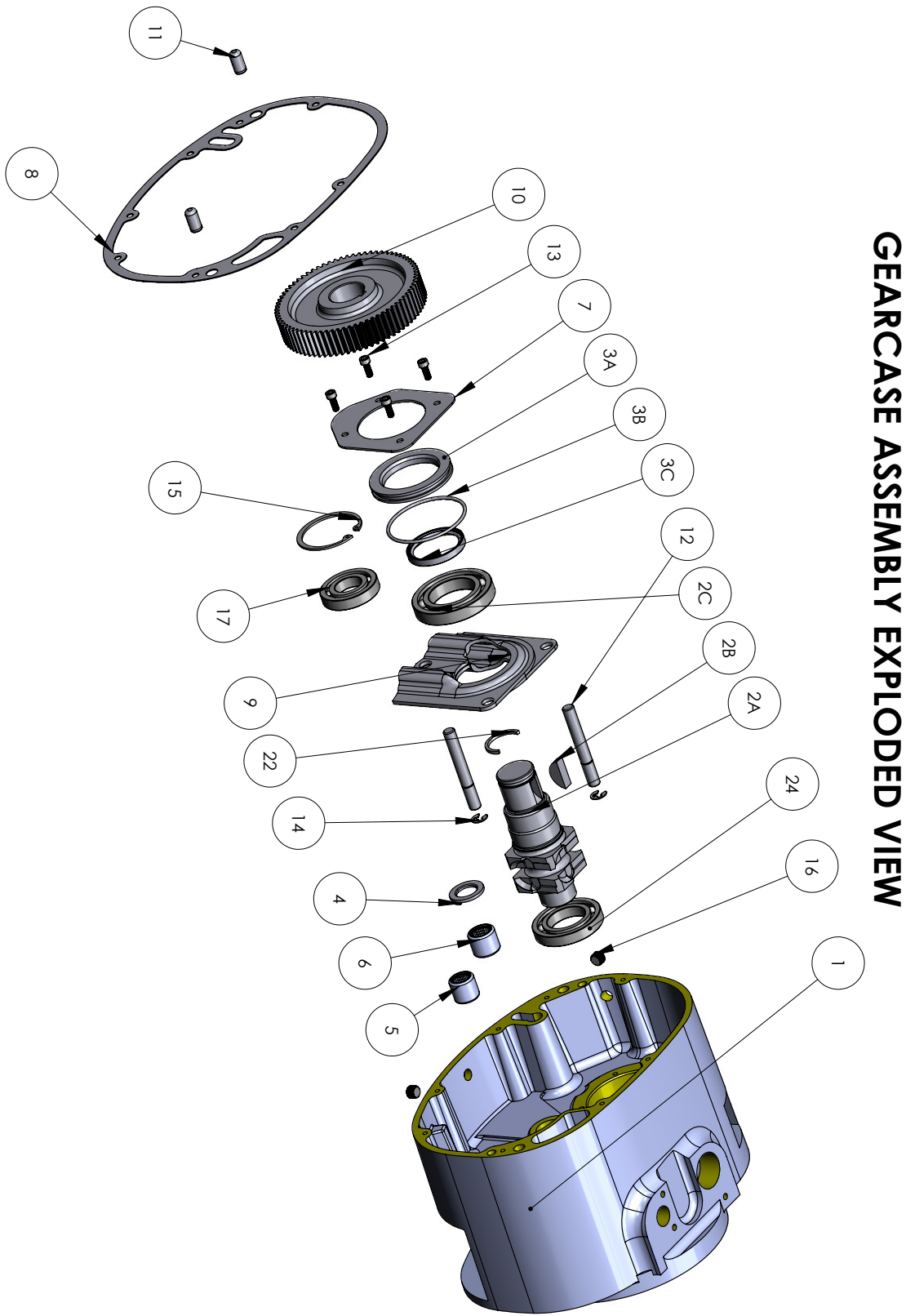

# GEARCASE ASSEMBLY EXPLODED VIEW

Figure 9-4. GEARCASE ASSEMBLY

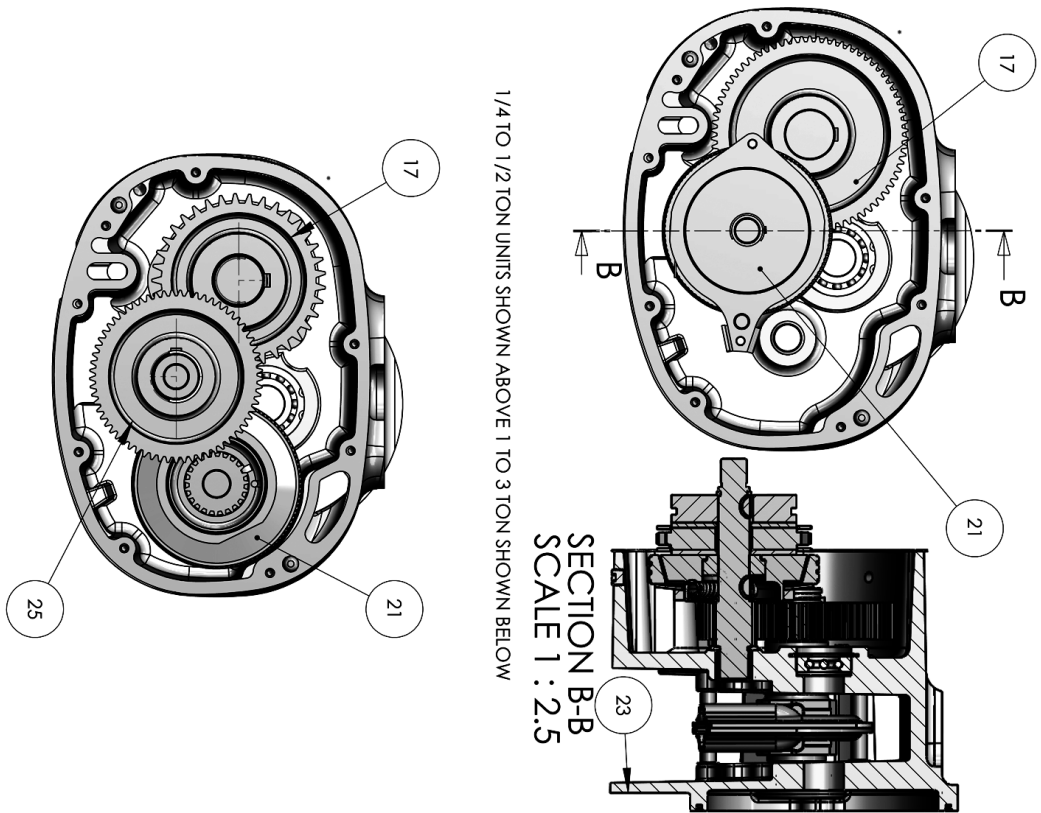

## GEARCASE ASSEMBLY

ITEM NO.	PART NUMBER	DESCRIPTION	QTY.
1	45142602Y	DIE-CAST FRAME (CASTING)	1
2 A,B&C	22952903	SPROCKET ASSEMBLY 1/4 AND 1/2 TON UNITS ONLY	1
2 A,B&C	22952901	SPROCKET ASSEMBLY 1, 2 AND 3 TON UNITS ONLY	1
3 A,B &C	23247801	SPROCKET BEARING AND SEAL ASSEMBLY	1
4	10817301	BEARING THRUST WASHER	1
5	10380509	BEARING NEEDLE CLOSED	1
6	10380513	BEARING NEEDLE CLOSED	1
7	21552301	BEARING RETAINER	1
8	31177201	GASKET	1
9	21555601	CHAIN GUIDE	1
10	SEE BELOW	SPROCKET GEAR	1
10	21416903	1/4 TON 16 FPM, 1/2 TON 32 FPM	
10	21417003	1/4 TON 32 FPM, 1/2 TON 32 FPM	
10	21988103	1 TON 16 FPM, 1 TON 32 FPM, 2 TON 8 FPM, 3 TON 5 FPM AND 3 TON 10 FPM	
11	10770007	DOWEL PIN	2
12	11823201	CHAIN GUIDE PIN	2
13	NO14	#10-24 X 1/2	4
14	10261104	RETAINING RING	2
15	10008301	RETAINING RING	3
16	11619107	PIPE PLUG HEX SOCKET	2
17	10377306	BEARING	1
18	SEE BELOW	MAN GUARD LOAD PROTECTOR SINGLE SPEED UNITS ONLY (NOT SHOWN)	1
18	23456134	1/4 TON 16 FPM	
19	23456135	1/4 32 FPM	
20	23456132	1/2 TON 32 FPM, 1 TON 16 FPM, 1 TON 32 FPM, 2 TON 8 FPM, 2 TON 16 FPM, 3 TON 10 FPM AND 3 TON 3 FPM	
20	23456131	1/2 TON 16 FPM	
21	SEE BELOW	LOAD-BRAKE/MAN GUARD VARIABLE SPEED UNITS	1
21	51659034	1/4 TON 16 FPM	
21	51659035	1/4 32 FPM	
21	51659032	1/2 TON 32 FPM, 1 TON 16 FPM, 1 TON 32 FPM, 2 TON 8 FPM, 2 TON 16 FPM, 3 TON 10 FPM AND 3 TON 5 FPM	
21	51659031	1/2 TON 16 FPM	
22	10417701	C - CLIP	1
23	10402823	SLEEVE BEARING	1
24	NO3042	BEARING	1
60	44468913	SHAFT INTERMEDIATE ASSEMBLY 1 TO 3 TON UNITS ONLY	1

Figure 9-4. GEARCASE ASSEMBLY, CONT'D

To enable us to expedite your parts order, always give Model and Catalog Number and Electric Current of Hoist. (See nameplate.)

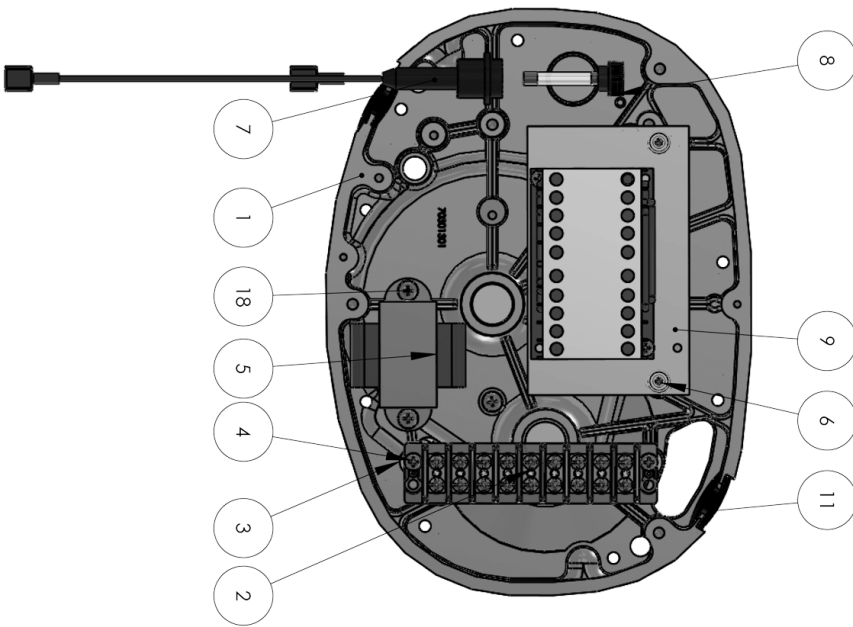

## SINGLE SPEED GEARCASE COVER WITH CONTROLS 1 PHASE UNITS

ITEM NO.	PART NUMBER	DESCRIPTION	QTY.
1	44485113Y	GEARCASE COVER w/ BEARINGS	1
2	11741009	TERMINAL STRIP	1
3	10755401	SPACER	2
4	10381402	PHILLIP SCREW PAN HEAD #10-24X1	2
5	22827201	TRANSFORMER	1
6	10017807	10-24 1/4 PAN HEAD SELF TAPPING	2
7	11832399	FUSE HOLDER FOR GLR FUSES	1
8	11832302	GLR FUSE	1
9	22845703	REVERSING CONTACTOR ASSEMBLY	1
12	11050704	10-24 3/8 PAN HEAD SELF TAPPING	2
11	10734601	GROMMET	2
14	20055696	WIRE GROUND #16 GA X 7" LONG COLOR GREEN	1
15	10486615	WIRE JUMBER #14 GA X 3" LONG COLOR BLACK	1
16	22700310	WIRE JUMBER #16 GA X 7.5" COLOR BLACK	5
17	20995407	WIRE JUMBER #16 GA X 2.5" COLOR RED	1
18	10777102	PHILLIP SCREW PAN HEAD #10-24 x 3/8 SCREW PHILLIPS PAN HEAD SEMS	3

NOTE:  
1. JUMPER AND WIRE CONNECTIONS NOT SHOWN.  
2. SEE WIRING DIAGRAMS FOR WIRE CONNECTIONS.

Figure 9-5A. CONTROLS SINGLE SPEED SINGLE PHASE



## SINGLE SPEED GEARCASE COVER WITH CONTROLS 3 PHASE UNITS

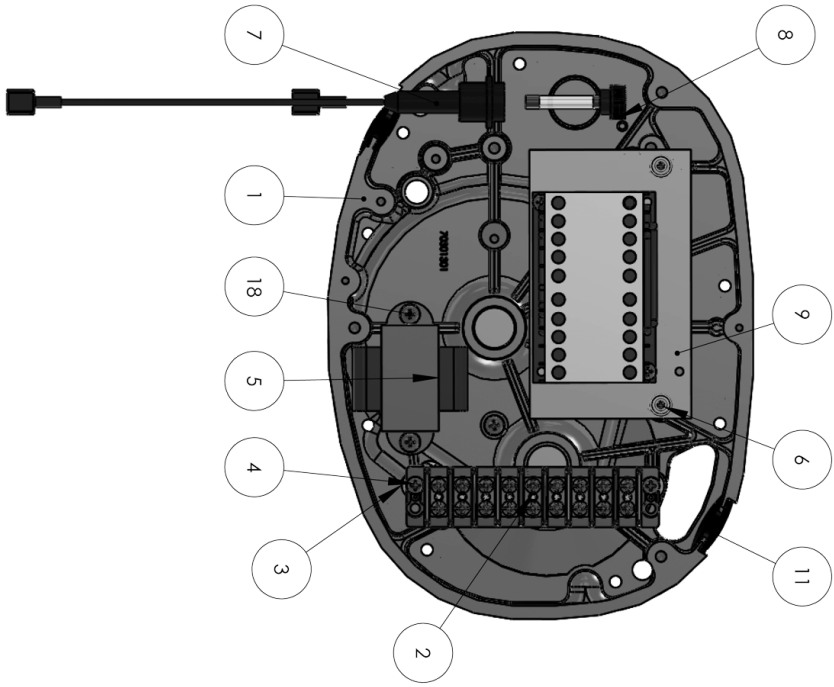

ITEM NO.	PART NUMBER	DESCRIPTION	QTY.
1	44485113Y	GEARCASE COVER w/ BEARINGS	1
2	11741009	TERMINAL STRIP	1
3	10755401	SPACER	2
4	10381402	PHILLIP SCREW PAN HEAD #10-24X1	2
5	20991908	TRANSFORMER	1
6	10017807	10-24 1/4 PAN HEAD SELF TAPPING	2
7	11832399	FUSE HOLDER FOR GLR FUSES	1
8	11832302	GLR FUSE	1
9	22845703	REVERSING CONTACTOR ASSEMBLY	1
12	11050704	10-24 3/8 PAN HEAD SELF TAPPING	2
11	10734601	GROMMET	2
14	20055696	WIRE GROUND #16 GA X 7" LONG COLOR GREEN	1
15	10486615	WIRE JUMBER #14 GA X 3" LONG COLOR BLACK	2
16	22700310	WIRE JUMBER #16 GA X 7.5" COLOR BLACK	6
17	10777102	PHILLIP SCREW PAN HEAD #10-24 X 3/8 SCREW PHILLIPS PAN HEAD SEMS	3

- NOTE:  
 1. JUMPER AND WIRE CONNECTIONS NOT SHOWN.  
 2. SEE WIRING DIAGRAMS FOR WIRE CONNECTIONS.

Figure 9-5B. CONTROLS SINGLE SPEED THREE PHASE

## VFD GEARCASE COVER WITH CONTROLS 230VOLT AND 460 VOLT MODELS.

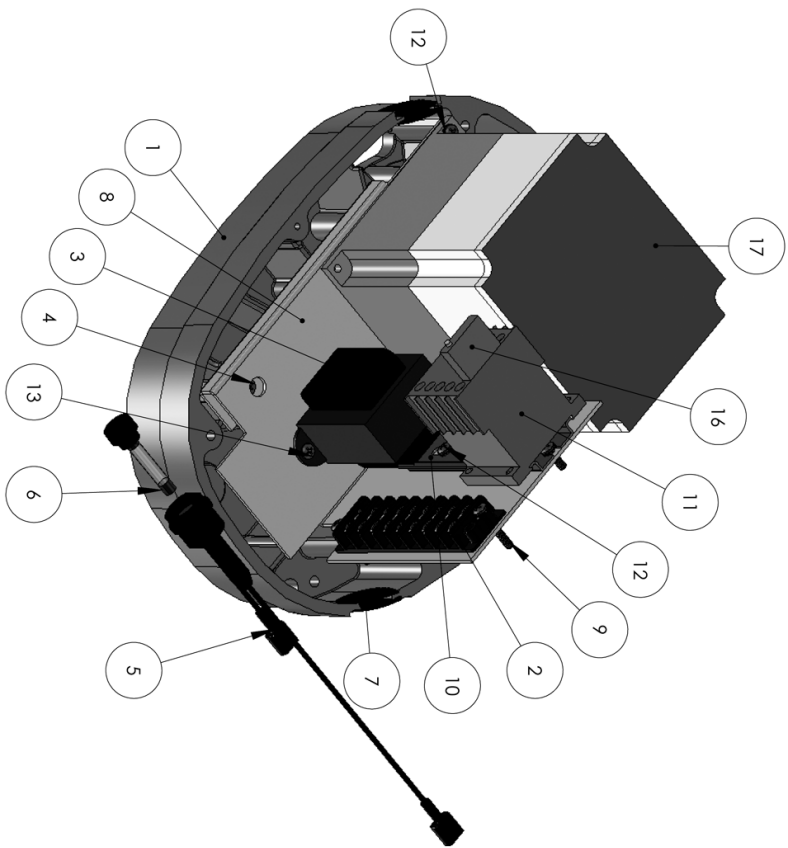

ITEM NO.	PART NUMBER	DESCRIPTION	QTY.
1	44485113Y	GEARCASE COVER	1
2	11741009	TERMINAL STRIP	1
3	20991909	TRANSFORMER	1
4	10777102	PHILLIP SCREW PAN HEAD #10-24 x 3/8 SEMS	3
5	11832399	FUSE HOLDER GLR FUSE	1
6	11832302	GLR FUSE	1
7	10734601	GROMMET	2
8	45226901	VFD BRACKET	1
9	11050706	8-32 x 1 PHILLIPS PAN HEAD SEM	2
10	129009	DIN-RAIL 4.50" LONG	1
11	28871	CONTACTOR, MINI NON-REVERSING	1
12	11050712	8-32X1/2 PAN HEAD PHILLIPS SEM	4
13	11050704	10-24 1/4 PAN HEAD SELF TAPPING	2
14	NO8102	1/4-20X1/2 PHILLIP HEAD SEMS	1
15	10017801	1/4-20X7/8	1
16	33311996	SUPPRESSOR MODULE W/ LED	1
17	VFD PART NUMBER	VFD DESCRIPTION	1
A	45199742	460 VOLTS, 1/4 TON 16 AND 32FPM AND 1/2 TON 16 FPM	1
B	45199742	460 VOLTS, 1/2 TON 32FPM AND 1 TON 16 FPM	1
C	45199743	460 VOLTS, 1 TON 16 32 FPM 2 TON 16FPM AND 3 TON 10 FPM	1
D	45199722	230 VOLTS, 1/4 TON 16 AND 32FPM AND 1/2 TON 16 FPM	1
E	45199722	230 VOLTS, 1/2 TON 32FPM AND 1 TON 16 FPM	1
F	45199723	230 VOLTS, 1 TON 32 FPM 2 TON 16FPM AND 3 TON 10 FPM	1
18	10486616	WIRE JUMPER BLACK 13.75" 14 GA.	3
19	122700310	WIRE JUMPER BLACK 7.5" 16 GA.	2
20	10486619	WIRE JUMPER 13.5 RED 18 GA.	9
21	20055698	GROUND JUMPER 14 GA WITH RING	1
22	11782702	CONNECTOR PUSHWIRE	3
23	10916301	WIRE TIE	6
24	33179001PC	ELEC. COMP COVER EXTENSION	1

NOTE:  
 1. ITEM 17 A-F SEE DESCRIPTION FOR PROPER SELECTION OF VFD. QTY. OF 1 REQUIRED.  
 2. ITEMS 18-24 NOT SHOWN SEE WIRING DIAGRAM FOR WIRE CONNECTIONS.

Figure 9-5C. CONTROLS VARIABLE SPEED THREE PHASE

## AC BRAKE

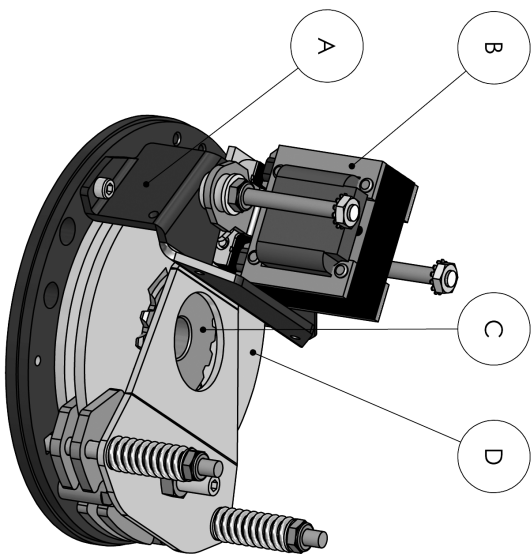

ITEM #	PART #	DESCRIPTION
	45097304	Motor Brake - 1/4 HP 1800RPM 115V/230V 1 Phase
	45097301	Motor Brake - 1/4 HP 1800RPM 230V/460V 3 Phase
	45097310	Motor Brake - 1/2 HP 1800RPM 115V/230V 1 Phase
	45097310	Motor Brake - 1 HP 3600RPM 115V/230V 1 Phase
	45097307	Motor Brake - 1/2 HP 1800RPM 230V/460V 3 Phase
	45097307	Motor Brake - 1 HP 3600RPM 230V/460V 3 Phase
	45097316	Motor Brake - 1 HP 1800RPM 115V/230V 1 Phase
	45097316	Motor Brake - 2-1/4 HP, 2-1/2 HP 3600RPM 115V/230V 1 Phase
	45097313	Motor Brake - 1 HP 1800RPM 230V/460V 3 Phase
	45097313	Motor Brake - 2-1/4 HP, 2-1/2 HP 3600RPM 230V/460V 3 Phase
B	45097396	SOLENOID KIT
C	45097399	BRAKE HUB
D	45097350	BRAKE DISC (SPECIFY QTY. SOME BRAKES ASSEMBLIES USE 2)
E	45097397	BRAKE COVER (NOT SHOWN)
F	45097395	HARDWARE KIT FOR BRAKE COVER AND HUB (NOT SHOWN)
G	10095703	3/8 LOCKWASHER FOR BRAKE MOUNTING (NOT SHOWN)
H	10119413	RETAINING RING FOR BRAKE HUB (NOT SHOWN)
I	N02112	SHCS 3/8 FOR BRAKE MOUNTING (NOT SHOWN)

Figure 9-6. BRAKES

## MOTORS

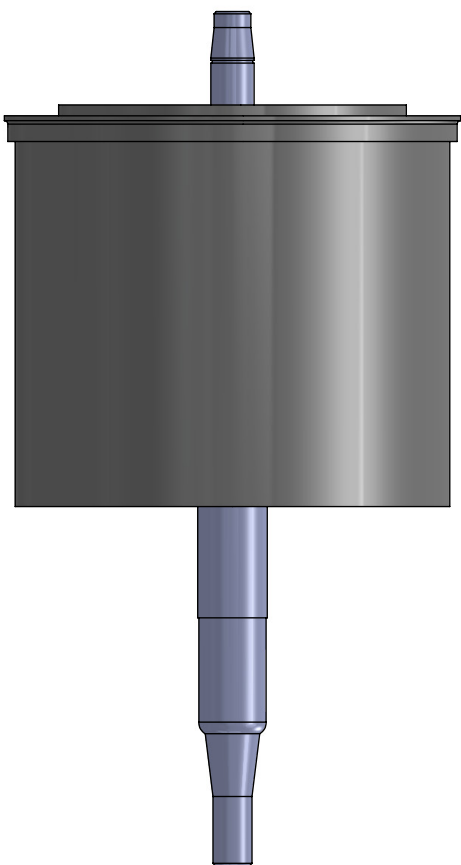

PART CODE	PHASE	CAPACITY	SPEED
45089072	1	1/4	16 FT/MIN
45089074	1	1/4	32 FT/MIN
45089076	1	1/2	32 FT/MIN
45089074	1	1/2	16 FT/MIN
45089076	1	1	16 FT/MIN
45089076	1	2	8 FT/MIN
45089076	1	3	5 FT/MIN
45089102	3	1/4	16 FT/MIN
45089105	3	1/4	32 FT/MIN
45089108	3	1/2	32 FT/MIN
45089105	3	1/2	16 FT/MIN
45089108	3	1	16 FT/MIN
45089122	3	1	32 FT/MIN
45089122	3	2	16 FT/MIN
45089122	3	3	10 FT/MIN

Figure 9-7. MOTORS

## CHAIN WITH LIMIT SWITCH

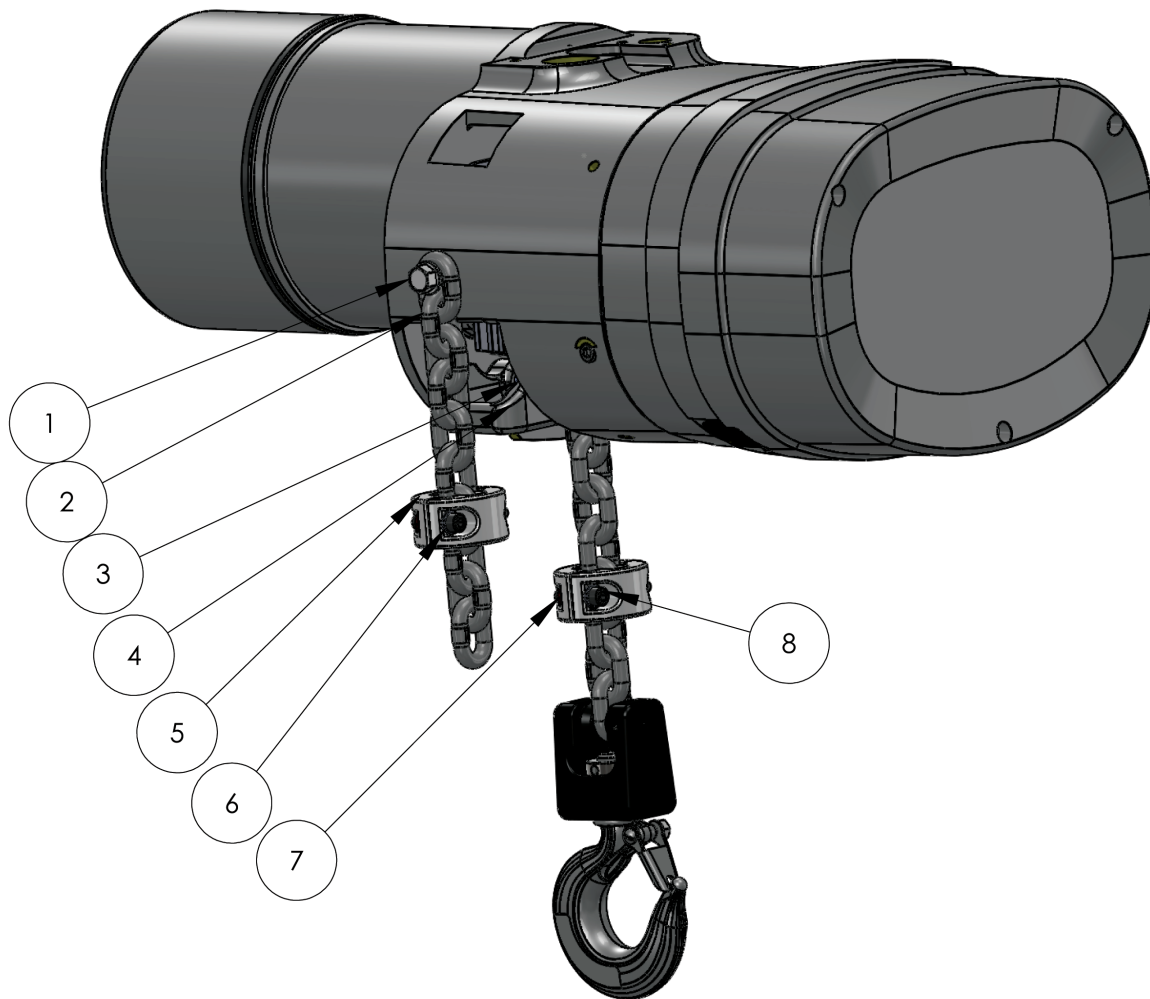

ITEM NO.	PART NUMBER	DESCRIPTION	QTY.
1	11829201	HEX FLANGE HEAD BOLT	1
2	85949/85944	CHAIN 1 TO 3 TON / 1/4 TO 1/2 TON	*
3	22716301	LIMIT SWITCH ASSEMBLY	1
4	33215901	LIMIT LEVER	1
5	23465603C (1 TO 3 TON) 23465903C (1/4 TO 1/2 TON)	LIMIT SWITCH ACTUATOR (REQ. 2)	2
6	10095701	LOCK WASHER	2
7	982514	NUT	2
8	982517	SCREW	2
9	10450808	KEY ( NOT SHOWN)	1
10	70301407	ELECTRICAL COMP.COVER	1

\*CHAIN QUANTITY = DROP + 1.75' FOR 1/4 TO 1 TON HOIST,  
 DROP X 2 + 3.25' FOR 2 TON HOIST  
 AND DROP X 3 + 4.75' FOR 3 TON HOIST.

Figure 9-8. LIMIT SWITCH ASSEMBLY WITH STOPS AND CHAIN

# 115V-1PH-60HZ SINGLE SPEED UNITS ONLY

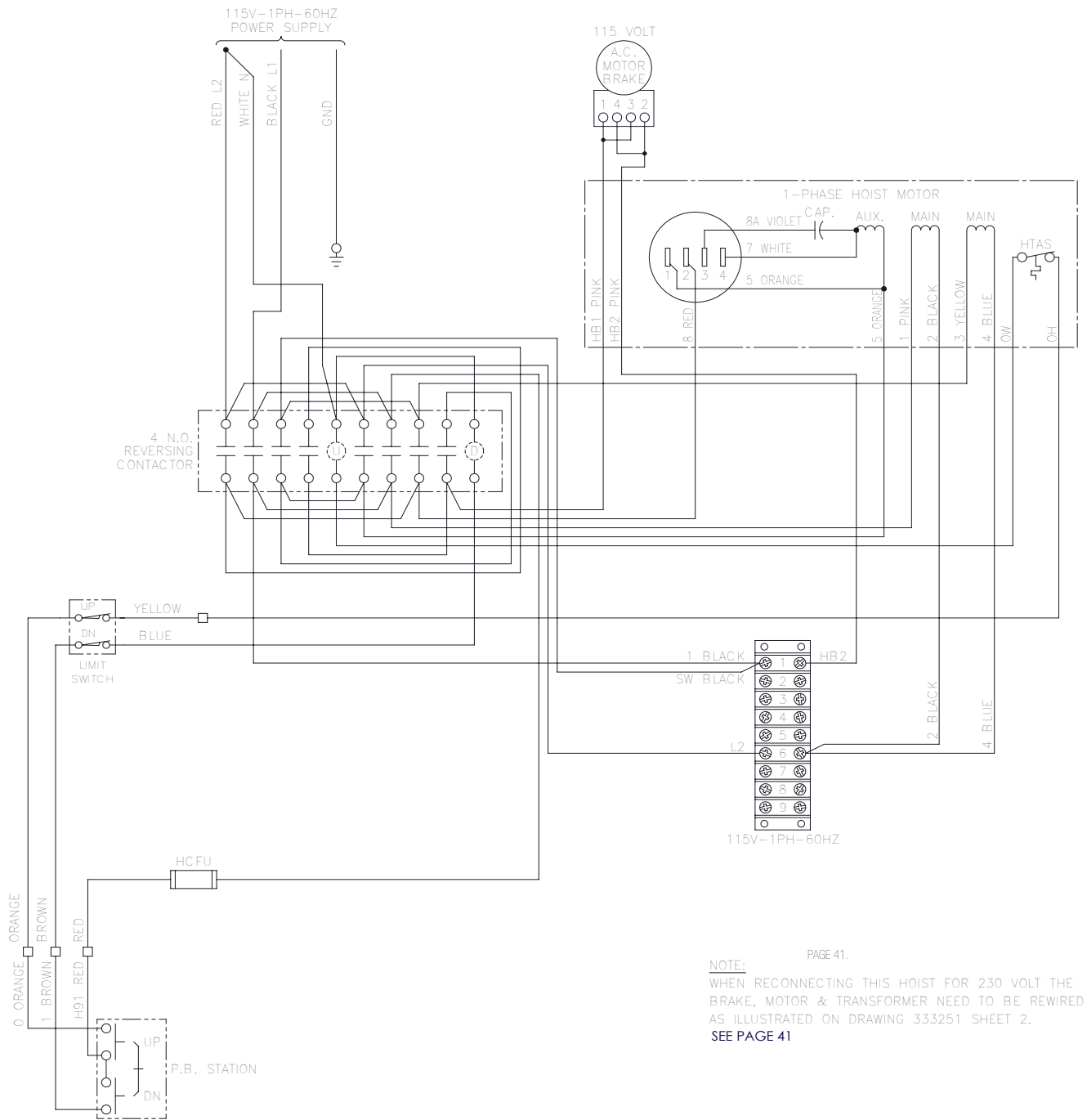

NOTE: PAGE 41.  
 WHEN RECONNECTING THIS HOIST FOR 230 VOLT THE BRAKE, MOTOR & TRANSFORMER NEED TO BE REWIRED AS ILLUSTRATED ON DRAWING 333251 SHEET 2.  
 SEE PAGE 41

Figure 9-9a. WIRING DIAGRAMS

# 230V-3PH-60HZ SINGLE SPEED UNITS ONLY

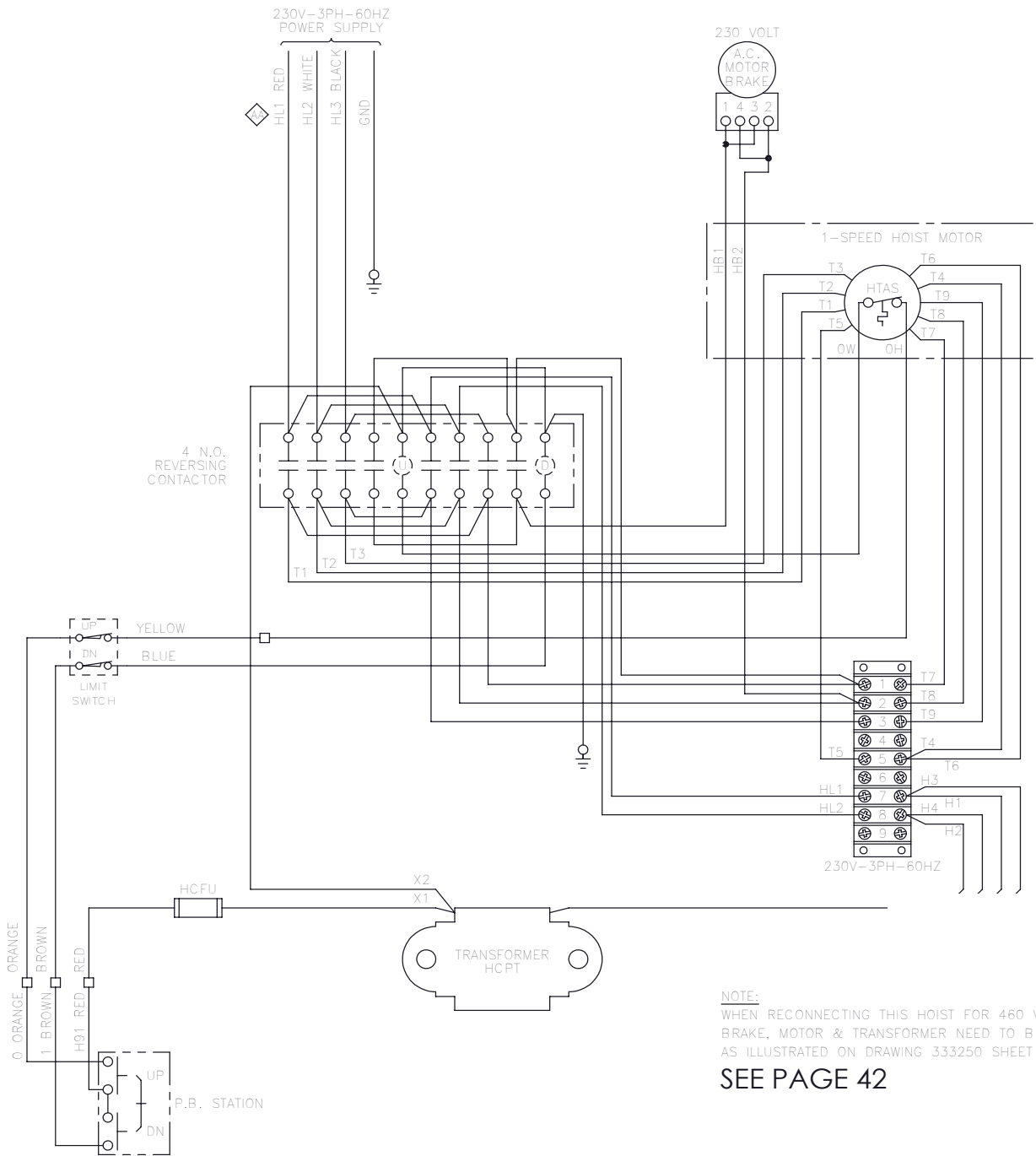

**NOTE:**  
WHEN RECONNECTING THIS HOIST FOR 460 VOLT THE BRAKE, MOTOR & TRANSFORMER NEED TO BE REWIRED AS ILLUSTRATED ON DRAWING 333250 SHEET 2.

**SEE PAGE 42**

**Figure 9-9b. WIRING DIAGRAMS**

# INFINITELY VARIABLE FREQUENCY DRIVE UNITS ONLY

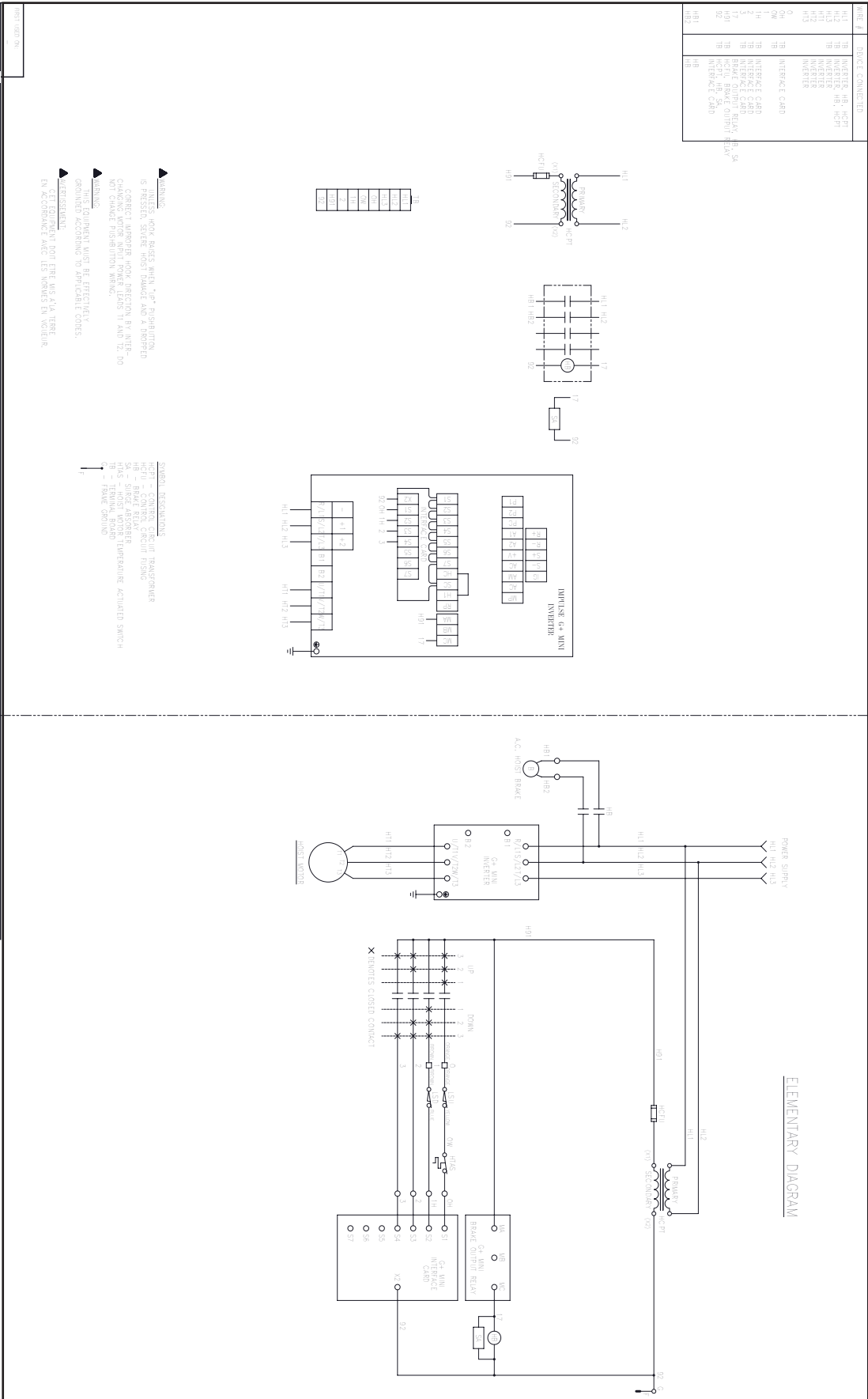

Figure 9-9c. WIRING DIAGRAMS

# 230V-1PH-60HZ SINGLE SPEED UNITS ONLY

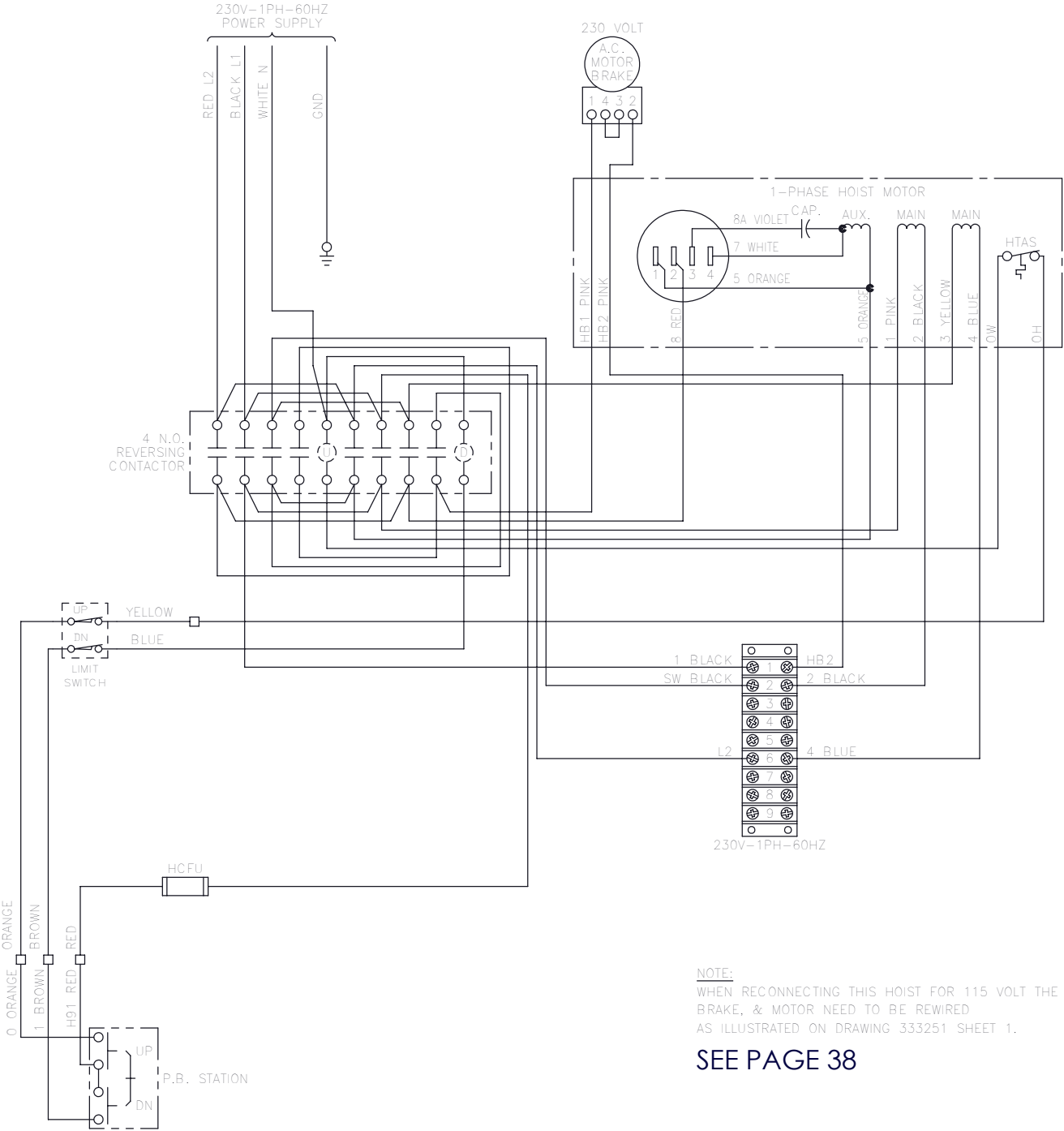
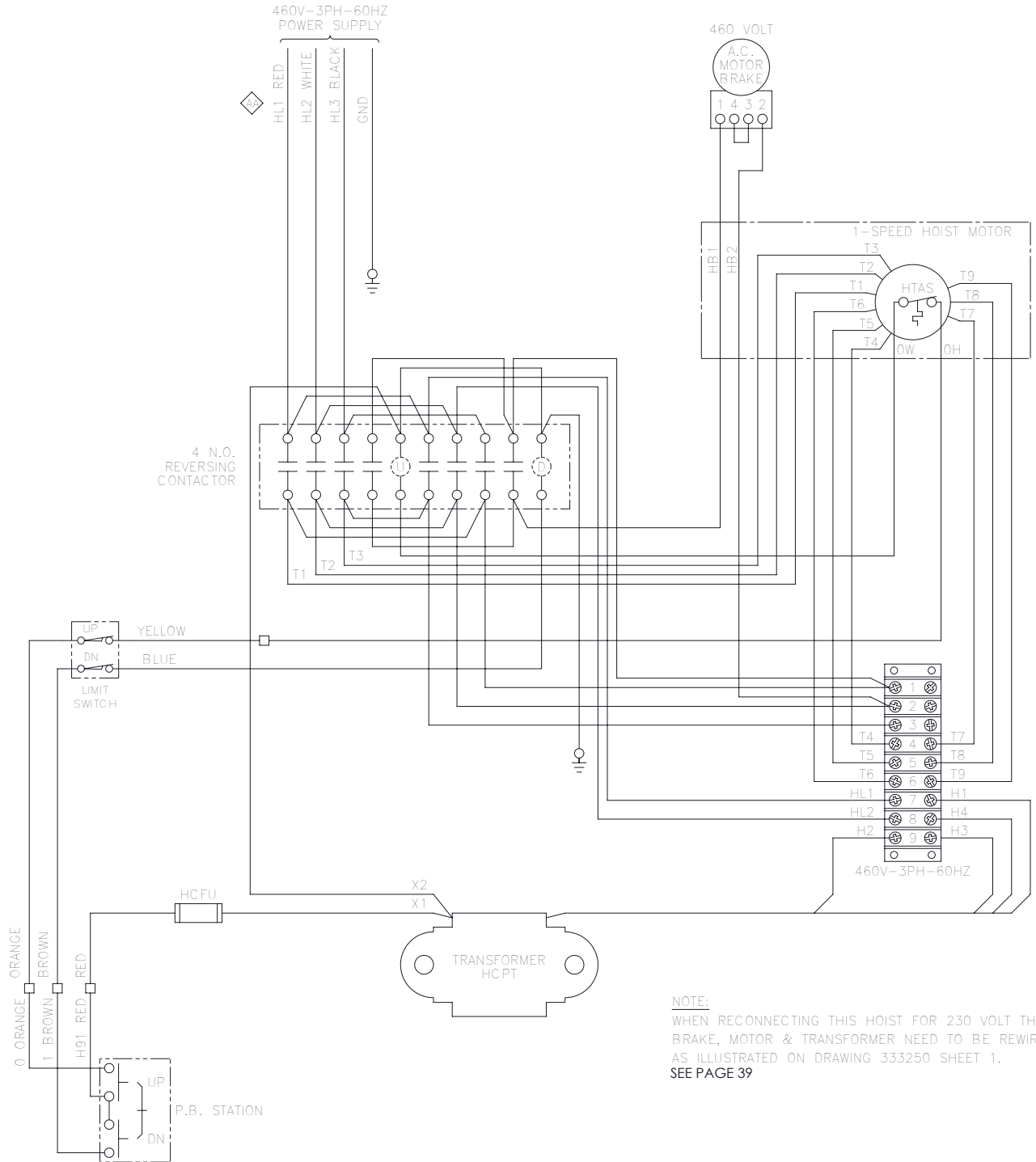

Figure 9-9d. WIRING DIAGRAMS



# 460V-3PH-60HZ SINGLE SPEED UNITS ONLY



**NOTE:**  
WHEN RECONNECTING THIS HOIST FOR 230 VOLT THE BRAKE, MOTOR & TRANSFORMER NEED TO BE REWIRED AS ILLUSTRATED ON DRAWING 333250 SHEET 1.  
**SEE PAGE 39**

**Figure 9-9e. WIRING DIAGRAMS**

# PENDANT AND POWER CABLE ASSEMBLIES

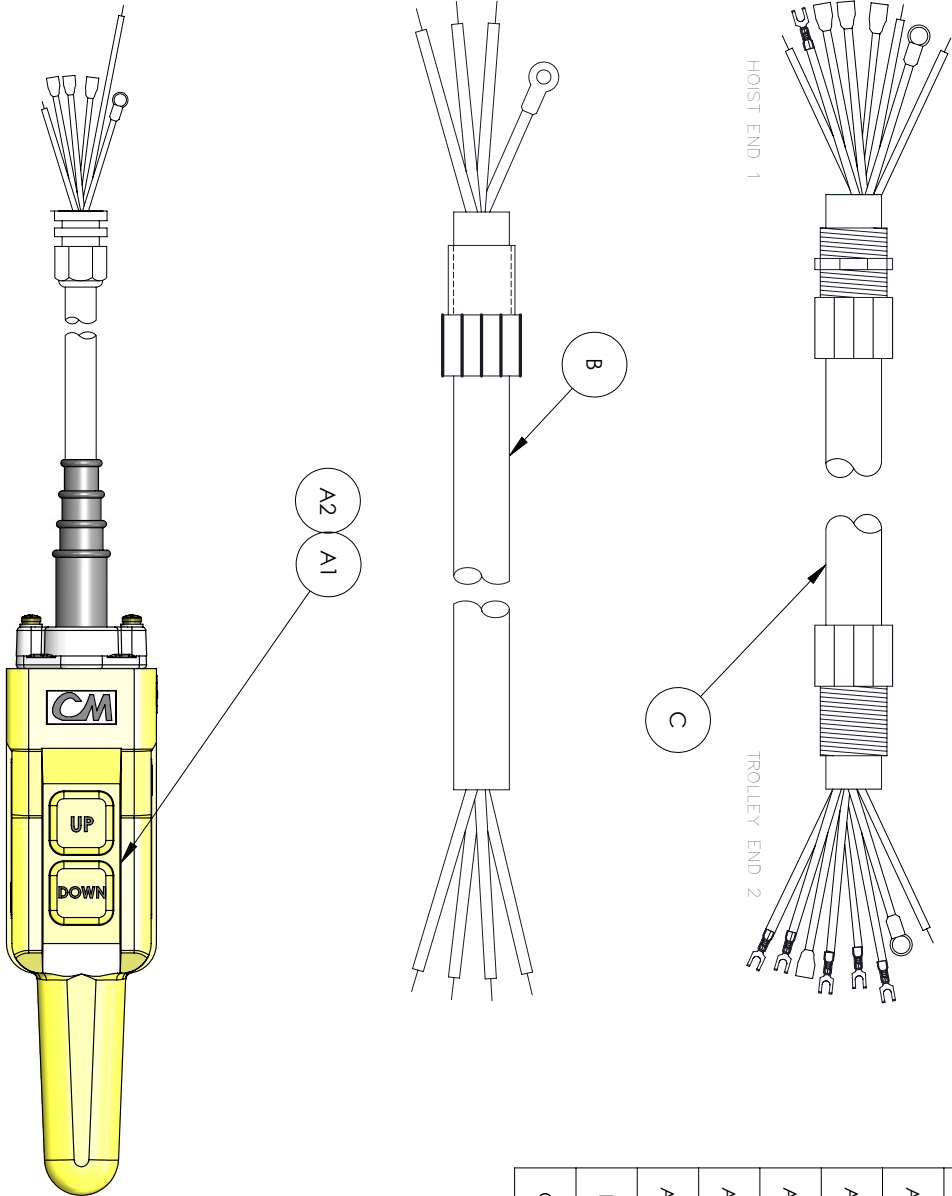

ITEM #	PART CODE	DESCRIPTION
A1	33211206B	SINGLE SPEED PUSHBUTTON STATION 6FT DROP
A1	33211211B	SINGLE SPEED PUSHBUTTON STATION 11FT DROP
A1	33211216B	SINGLE SPEED PUSHBUTTON STATION 16FT DROP
A2	33091706B	VFD PUSHBUTTON STATION 6FT DROP
A2	33091711B	VFD PUSHBUTTON STATION 11FT DROP
A2	33091716B	VFD PUSHBUTTON STATION 16FT DROP
B	23227305	SHORT POWER CABLE SINGLE OR 3 PHASE
C	11568503	POWER/CONTROL CABLE USED WITH MOTOR DRIVEN TROLLEYS

# HDPE CHAIN CONTAINERS

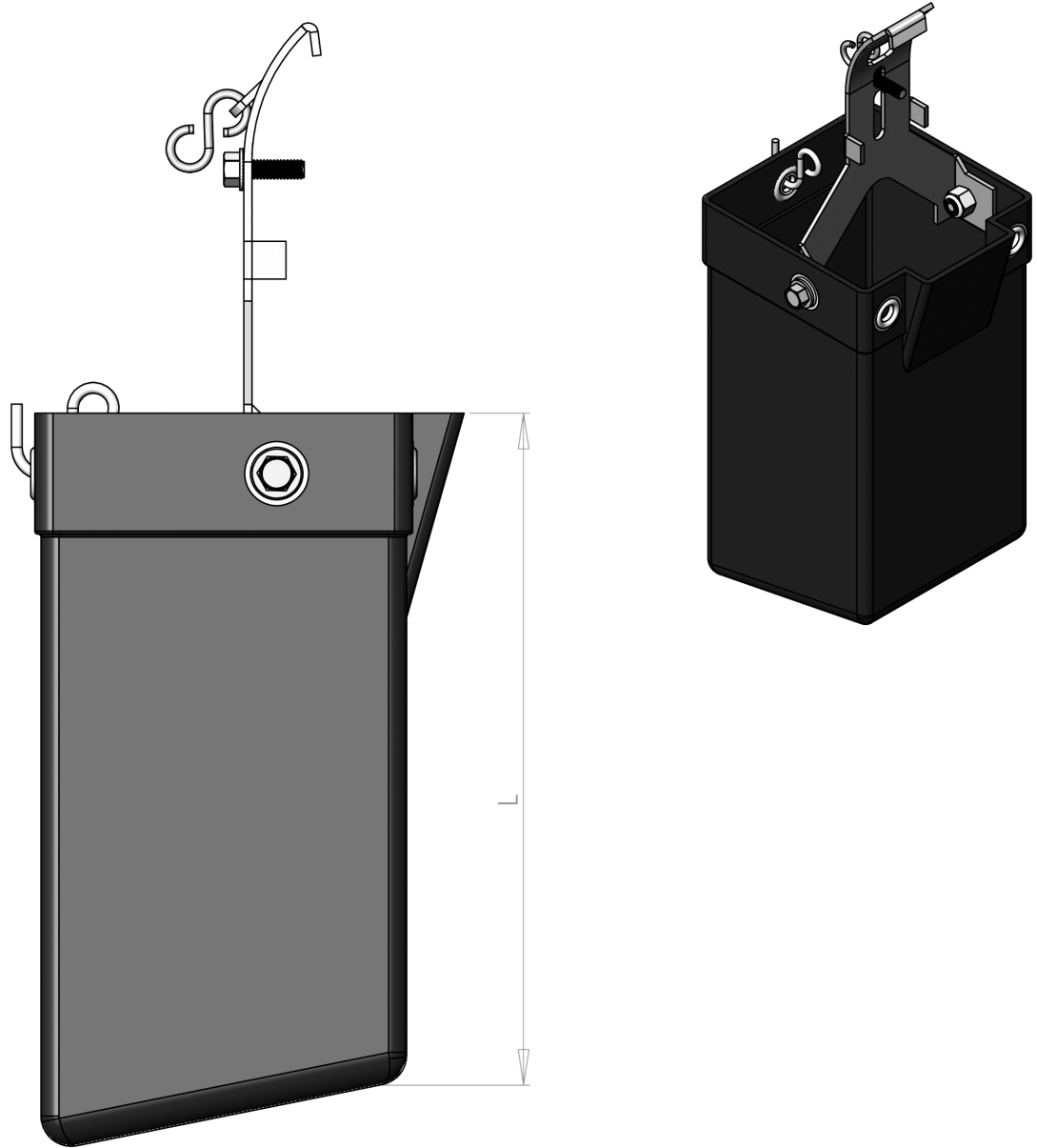

CODE #	922440	922441	922442	922443
MAX CHAIN	18'	28'	40'	50'
"L"	8.9"	11"	14.5"	18.75"

## Recommended Spare Parts for Your CM Hoists

Certain parts of your hoist will, in time, require replacement under normal wear conditions. It is suggested that the following parts be purchased for your hoist as spares for future use.

Set of Gaskets	Contactors
Set of Bearings	Transformer Fuse
Set of Oil Seals	Limit Lever
Lower Block Assembly	Limit Switch Assembly
Load Chain	
Set of Brake Discs for Load Brake	
Set of Brake Discs for Motor Brake	
Push Button Station & Cable Assembly	
Transformer	

**Note: When ordering parts always furnish Model and Catalog Number of Hoist and lift of hoist on which the parts are to be used.**

Parts for your hoist are available from your local authorized **CM Hoists** repair station.  
For the location of your nearest repair station, call or visit:

**Phone: (800) 888-0985 • [www.cmworks.com](http://www.cmworks.com) • Fax: (716) 689-5644**

# WARRANTY

## WARRANTY AND LIMITATION OF REMEDY AND LIABILITY

A. Seller warrants that its products and parts, when shipped, and its work (including installation, construction and start-up), when performed, will meet applicable specifications, will be of good quality and will be free from defects in material and workmanship. All claims for defective products or parts under this warranty must be made in writing immediately upon discovery and in any event, within one (1) year from shipment of the applicable item unless Seller specifically assumes installation, construction or start-up responsibility. All claims for defective products or parts when Seller specifically assumes installation, construction or start-up responsibility and all claims for defective work must be made in writing immediately upon discovery and in any event, within one (1) year from completion of the applicable work by Seller, provided; however, all claims for defective products and parts must be made in writing no later than eighteen (18) months after shipment. Defective items must be held for Seller's inspection and returned to the original f.o.b. point upon request. THE 'FOREGOING IS EXPRESSLY IN LIEU OF ALL OTHER WARRANTIES WHATSOEVER, EXPRESS, IMPLIED AND STATUTORY, INCLUDING, WITHOUT LIMITATION, THE IMPLIED WARRANTIES OF MERCHANTABILITY AND FITNESS.

B. Upon Buyer's submission of a claim as provided above and its substantiation, Seller shall at its option either (i) repair or replace its product, part or work at either the original f.o.b. point of delivery or at Seller's authorized service station nearest Buyer or (ii) refund an equitable portion of the purchase price.

C. This warranty is contingent upon Buyer's proper maintenance and care of Seller's products, and does not extend to normal wear and tear. Seller reserves the right to void warranty in event of Buyer's use of inappropriate materials in the course of repair or maintenance, or if Seller's products have been dismantled prior to submission to Seller for warranty inspection.

D. The foregoing is Seller's only obligation and Buyer's exclusive remedy for breach of warranty and is Buyer's exclusive remedy hereunder by way of breach of contract, tort, strict liability or otherwise. In no event shall Buyer be entitled to or Seller liable for incidental or consequential damages. Any action for breach of this warranty must be commenced within one (1) year after the cause of action has accrued.



Printed in U.S.A.