



## A REDUCED VOLTAGE SOFT START FOR APPLICATIONS NEEDING COST-EFFICIENT MOTOR CONTROL.

Versatility, reliability and value are the three words that best describe Magnetek's Electromotive Systems MAC™•2000 Motor Acceleration Control.

### VERSATILE

The MAC•2000 unit can be utilized for single and two-speed applications in a 230, 460V or 575V model for up to 15.2 amps.

### RELIABLE

MAC•2000 has been designed specifically to recognize the high duty cycle start, stop and jogging conditions that are associated with overhead material handling applications.

### VALUE

The versatile design of this motor acceleration control reduces the need to maintain inventories of units with various voltage and speed capabilities, common with other soft start products. In addition, this unit has been produced to recognize the needs of our customers for a low cost control device for less sophisticated applications.

### QUALITY DESIGN AND VERSATILE FEATURES KEEP YOU UP AND RUNNING

Check out the additional features included in our MAC•2000 Control and include it as part of your crane control solution.

- Adjustable starting torque and acceleration time
- Compact size
- Voltage ramp reset
- Phase loss protection
- Rugged construction for mounting on traveling cranes and monorails
- CMAA Class "D" Service
- 230, 460 or 575 VAC, 3-phase input voltage
- No control signals are required. Simply connect power supply input and motor output
- Phase insensitive – L1, L2, L3-input voltage leads can be wired in any sequence
- UL/cUL Listed



MAC•2000 can be easily applied to an existing contactor on a crane for single or two speed applications, or it may be ordered to use with pre-engineered contactor panel.

### PRODUCT SPECIFICATIONS

**Voltage Rating:**

230/460V–15.2 Amp, 3 Phase

575V–15.2 Amp, 3 Phase

**Application:**

Single or Two Speed

**Duty Cycle:**

Up to CMAA Class "D" Service

**Frequency:**

50/60 Hz

**Overload Capacity:**

250% of Rated Current for 1 Minute

300% of Rated Current for 40 Seconds

450% of Rated Current for 5 Seconds

**Ambient Temperature:**

14° to 104°F (-10° to +40°C )

**Dimensions:**

4.12"W x 7.18"H x 2.62"D

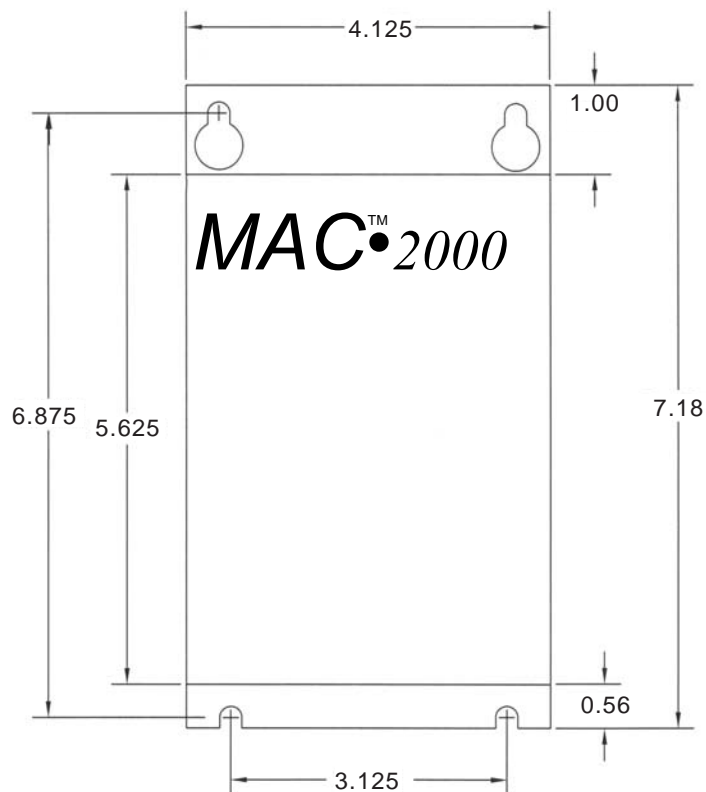

N49 W13650 Campbell Drive  
Menomonee Falls, WI 53051  
Toll-Free Phone 800.288.8178  
Toll-Free Fax 800.298.3503  
Phone 262.783.3500  
Fax 262.783.3510

WWW.MAGNETEKM.H.COM

Pub No. mac2000\_09

© Magnetek, Inc. 2009

For more information, contact Magnetek Material Handling or your local Magnetek Sales Representative.