

Heavy-Duty Aluminum Festoon Systems

Magnetek's Electromotive Systems Heavy-Duty Aluminum Festoon Systems, designed for environments requiring a more rugged track, efficiently and economically deliver power and control to cranes or monorails where festooning is applicable. These versatile systems can be furnished with a myriad of options, offering you maximum flexibility in the design of your festoon system. Components are also available from stock, allowing you to meet the needs of today's most demanding customers. In addition, Magnetek offers a full range of Electromotive Systems round, flat and specialty cable, designed specifically for festooning applications.

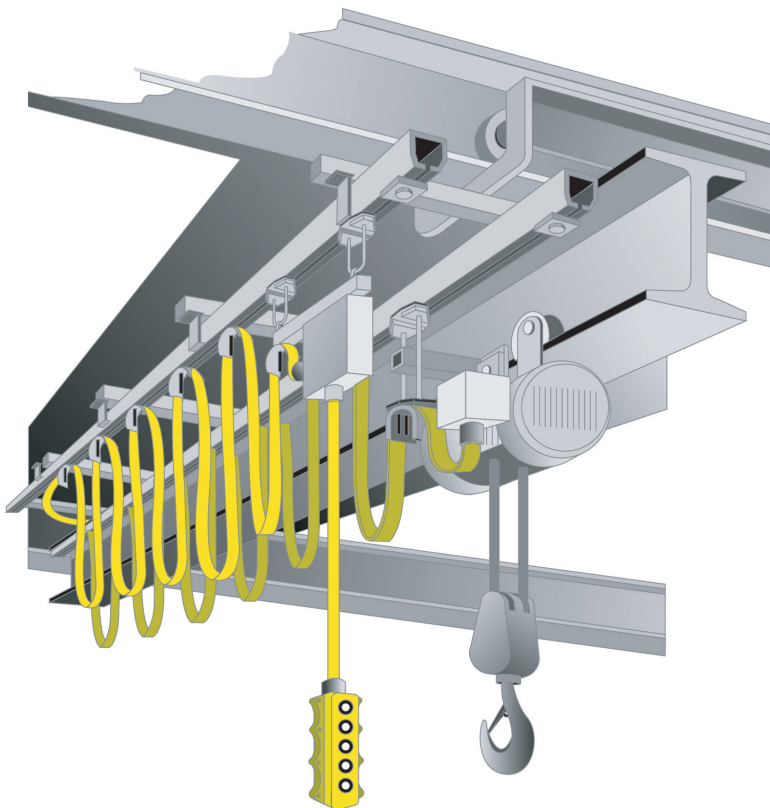

Features:

- 3" and 5" trolley frames
- Track may be formed to a minimum of a 36" radius
- Extruded aluminum track construction, in convenient lengths that simply bolt together
- Heavy-Duty coupling assembly
- Track may be formed to match the radii of curved material handling systems
- Tracks supported every 10 feet and the rounded portion serves as an extremely smooth runway for the cable trolleys
- Single and double flat and round cable trolley saddles available
- Trolleys are equipped with ball bearing wheels capable of traveling at speeds of 250 feet per minute. Each trolley can be supplied with anti-lift up rollers and is capable of supporting 150 lbs. of cable.

Build your own system with our festooning hardware and cable, or

let Magnetek completely assemble and wire your system to your specifications. Whatever your requirements, Magnetek can provide the power and control you need in a Heavy-Duty Aluminum Festoon System.

For more information contact Magnetek Material Handling or your local Magnetek Sales Representative.

MAGNETEK  **MATERIAL HANDLING**
Electromotive Systems Telemotive Mondel Engineering

YOUR ONE-STOP SOURCE FOR MATERIAL HANDLING CONTROL SOLUTIONS

N49 W13650 Campbell Drive ♦ Menomonee Falls, WI 53051 ♦ p:1-800-288-8178 ♦ f: 1-800-298-3503 ♦ w: www.magnetekmh.com

Heavy-Duty Aluminum Track

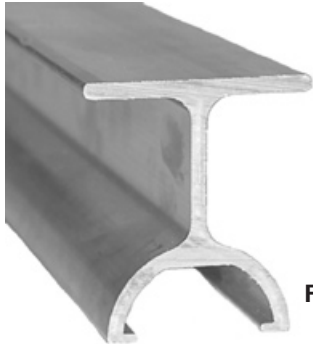

F-HT10

Heavy-duty track sections are manufactured of an aluminum extrusion, provided in 10' and 20' lengths. Sections may be formed to a minimum of 36" radius. Consult factory for details on formed sections. Sections may also be provided in cut-to-order lengths.

Track System	Catalog Number	Weight
Heavy-Duty	F-HT10 (10' length)	10 lbs.
	F-HT20 (20' length)	20 lbs.
	F-HTX ("X" length)*	1.0 lb./ft.

*Track sections may be cut to specific length (in one foot increments)

Tow Arm/Cable Saddle Assembly

Nylon cable saddle attached to a steel track to mount on moving equipment. Cable saddles are available for flat and round cable configurations.



F-HTA

Track System	Catalog Number	Weight
Heavy-Duty	F-HTA (powder coat finish)	3.25 lbs.
	F-HTA-SS (stainless steel)	3.25 lbs.
	F-HTA-2 (double saddle)	4.00 lbs.
	R-HTA (single round saddle)	3.50 lbs.
	R-HTA-2 (double round saddle)	4.00 lbs.

Joint Assembly

Coupling set consists of two parts. The top portion is used to bolt sections of heavy-duty track together. Bolts are inserted through the pre-punched holes in the track sections and the top coupling plate, then securely fastened on the top. The lower portion is installed through the curved section, and tightened with set screws.



F-HTJ

Track System	Catalog Number	Weight
Heavy-Duty	F-HTJ (gold dichromate finish)	1.5 lbs.

Hanger Assembly

Heavy gauge steel used to mount heavy-duty sections supporting channel or bracket.

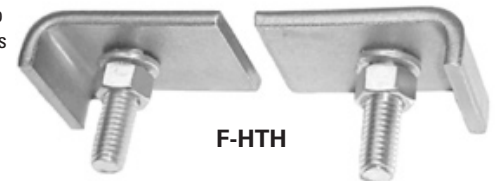

F-HTH

Track System	Catalog Number	Weight
Heavy-Duty	F-HTH (gold dichromate finish)	0.8 lbs.

End Cable Clamp

Nylon cable saddle with hardware used to secure cable at the storage end of the track. One required for each run of heavy-duty track. Cable saddles are available for flat and round cable configurations.

F-HTE



Track System	Catalog Number	Weight
Heavy-Duty	F-HTE	0.9 lbs.
	F-HTE-SS (stainless steel)	0.9 lbs.
	F-HTE-2 (double saddle)	1.7 lbs.
	R-HTE (single round saddle)	1.0 lbs.
	R-HTE-2 (double round saddle)	1.25 lbs.

Control Box Trolley

Two heavy-duty trolleys mounted to a C-Track section used to support a control box. Equipped with hardware and cable saddle. Flat and round cable saddle configurations are available.

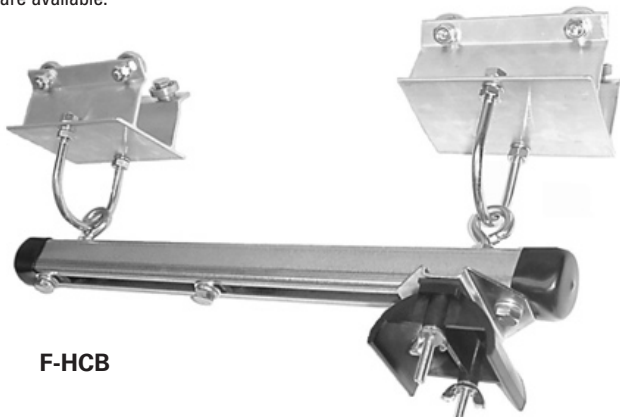

F-HCB

Track System	Catalog Number	Weight
Heavy-Duty	F-HCB	5.20 lbs.
	F-HCBX1 (corrosion resistant*)	5.20 lbs.
	F-HCB-2 (double saddle)	5.50 lbs.
	R-HCB (single round saddle)	5.20 lbs.
	R-HCB-2 (double round saddle)	5.50 lbs.

* Corrosion resistant trolley includes stainless steel parts and wheels. Steel parts are epoxy coated.

End Stop

For use in closing the active travel end of a heavy-duty track run. One required for each run of heavy-duty track.

F-HTS



Track System	Catalog Number	Weight
Heavy-Duty	F-HTS (gold dichromate finish)	0.6 lbs.
	F-HTS-SS (stainless steel)	0.6 lbs.

Trolley

Nylon cable saddle and aluminum trolley used to support flat cable. Cables may be stacked in the saddle. Flat and round cable saddle configurations are available. 150 lb. capacity each trolley.

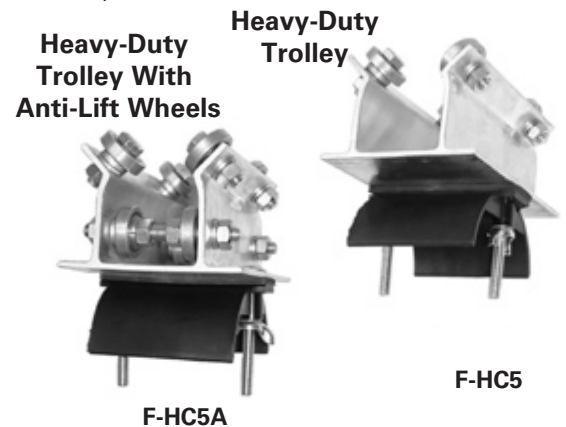

F-HC5A

F-HC5

Track System	Catalog Number	Weight
3" Trolley Frame	F-HC3	0.85 lbs.
5" Trolley Frame	F-HC5	1.25 lbs.
	F-HC5A (anti-lift rollers)	1.25 lbs.
	F-HC5X1 (corrosion resistant*)	1.25 lbs.
	F-HC5-2 (double saddle)	2.25 lbs.
	R-HC5 (single round saddle)	1.75 lbs.
	R-HC5-2 (double round saddle)	2.25 lbs.

* Corrosion resistant trolley includes stainless steel parts and wheels. Steel parts are epoxy coated.

Electromotive™ Cable

Magnetek furnishes a variety of Electromotive Systems cable specifically designed for festoon applications. The cable is available in a round or flat design and most sizes are available for same day shipment. It comes standard in a safety yellow color and can be ordered with your company's name, logo and phone number imprinted on the cable when purchased in reel quantities.

Standard Cable Specifications* :

- Indoor/Outdoor Festoon flat cable and round pendant control cable
 - 105° C (221° F) 600 volt A.C., 250 volt D.C.
 - Conductors are annealed copper
 - Each conductor has color coded jacket
 - Jacket rating -40° C (-40° F) to 105° C (221° F).
 - Resistant to UV, ozone, water, oil and weather
 - 4, 8, or 12 conductor flat cable
 - 8, 12, 16 or 24 conductor round pendant control cable
 - #2 Awg through #16 flat cable
 - #16 Awg round pendant control cable
- * Special cables are also available—contact the factory for more information.

Festoon Cable		Cable Grips		
Catalog Number	AWG/Conductors	Catalog Number	For Cables	Thread Type
F-2/4	2 Awg-4 Conductors	F-4CG1	(1) F-6/4 or (2)F-12/8	1.50" NPT
F-4/4	4 Awg-4 Conductors	F-4CG2	(1) F-10/4	1.00" NPT
F-6/4	6 Awg-4 Conductors	F-4CG3	(1) F-12/4 or (1) F-14/4	1.00" NPT
F-8/4	8 Awg-4 Conductors	F-4CG4	(1) F-2/4	2.00" NPT
F-10/4	10 Awg-4 Conductors	F-4CG11	(1) F-12/8	1.50" NPT
F-12/4	12 Awg-4 Conductors	F-4CG3	(1) F-12/4 or (1) F-14/4	1.00" NPT
F-14/4	14 Awg-4 Conductors	F-4/8CG2	(1) F-12/4 or (1) F-14/4 & (1) F-14/8 or (1) F-16/8	1.25" NPT
F-12/8	12 Awg-8 Conductors	F-8CG1	(1) F-14/8 or (1) F-16/8	1.25" NPT
F-14/8	14 Awg-8 Conductors	F-8CG2	(2) F-14/8 or (2) F-16/8 or (1) F-8/4	1.25" NPT
F-16/8	16 Awg-8 Conductors	F-12CG1	(1) F-14/12 or (1) F-16/12	2.00" NPT
F-14/12	14 Awg-12 Conductors	F-12CG2	(2) F-14/12 or (2) F-16/12 or (1) F-4/4	2.00" NPT
F-16/12	16 Awg-12 Conductors	F-12CG3	(3) F-14/12 or (3) F-16/12	2.00" NPT

Cable available in specific lengths or in full reels of 500 or 1000 feet.

Cable available in black color—Add Suffix "-B" to the catalog number.

Cable can be ordered with your company's name, logo and phone number in full reel quantities, which reminds customers where you can be reached for new equipment, parts or service.

Pendant		Cable Grips		
Catalog Number	AWG/Conductors	Catalog Number	Cable Diameter	Thread Type
	Strain Relief			
R-16/SR	16 Awg-8 Conductors	R-CG0	0.236" to 0.472" Inches Cable	.050" NPT
R-16/SR	16 Awg-12 Conductors	R-CG1	0.394" to 0.709" Inches Cable	0.75" NPT
R-16/SØ	16 Awg-16 Conductors	R-CG2	0.591" to 1.000" Inches Cable	1.00" NPT
R-16/SR	16 Awg-24 Conductors			
	Non Strain Relief			
R-16/8	16 Awg-8 Conductors			
R-16/12	16 Awg-12 Conductors			
R-16/16	16 Awg-16 Conductors			
R-16/24	16 Awg-24 Conductors			
R-16/30	16 Awg-30 Conductors			

Special flat and round cables are available. Contact the factory for additional information.



Electromotive

P.O. Box 13615
Milwaukee, WI 53213
Phone: 800-288-8178
Fax: 262-783-3510

N49 W13650 Campbell Drive
Menomonee Falls, WI 53051

WWW.MAGNETEKMH.COM

Brochure No. HD Aluminum Festoon Systems-06B-2
Copyright © 2006
Printed in U.S.A.