

Electrobar FS Conductor Bar System

Electromotive Electrobar FS Instruction Manual



MAGNETEK
MATERIAL HANDLING
ELECTROMOTIVE SYSTEMS

Part Number: 005-1066-R9
March 2011

© Copyright 2011 Magnetek Material Handling

Table of Contents

Chapter 1.0: Danger, Warnings and Cautions 3
Chapter 2.0: Disconnecting Means/Overcurrent Protection..... 4
Chapter 3.0: Assembly Guidelines 6
Chapter 4.0: Modular Hangers 11
Chapter 5.0: Joint Assembly 13
Chapter 6.0: Electrobar FS Expansion Elements..... 16
Chapter 7.0: Power Feed Wire/Connection 18
Chapter 8.0: Transfer Cap..... 23
Chapter 9.0: Collectors..... 24
Chapter 10.0: Final Inspection 29

Chapter 1.0: Danger, Warnings and Cautions

Many tests and procedures outlined in this manual involve exposure to components that operate at potentially lethal voltage levels. To eliminate this hazard, service personnel must ensure that the incoming three-phase AC power has been disconnected, locked out and tagged.

DISCLAIMER OF WARRANTY

Magnetek, hereafter referred to as Company, assumes no responsibility for improper use of supplied product by untrained personnel. Product should only be installed or repaired by a trained technician who has read and understands the contents of this manual. Improper installation or service can lead to unexpected, undesirable, or unsafe operation or performance. This may result in damage to equipment or personal injury. Company shall not be liable for economic loss, property damage, or other consequential damages or physical injury sustained by the purchaser or by any third party as a result of such operation or service. Company neither assumes nor authorizes any other person to assume for Company any other liability in connection with the sales or use of this product.

Chapter 4: MODULAR HANGERS – Danger, Warnings and Cautions

REPLACEMENT SNAP-IN HANGERS ARE NOT RE-USABLE! If removed to relocate hardware in the hanger base during installation, new replacement hanger clips must be used when the modular hanger is re-assembled.

Chapter 5: JOINT ASSEMBLY – Danger, Warnings and Cautions

Standard Joint Covers are shipped with foam packaging located on the inside of the joint cover. Please remove prior to assembly.

PRODUCT WARRANTY INFORMATION

For information on Magnetek's product warranties by product type please visit www.magnetekmh.com.

©2011 MAGNETEK

All rights reserved. This notice applies to all copyrighted material, included with this product, including, but not limited to, this manual and software embodied within the product. This manual is intended for the sole use of the persons to whom it was provided, and any unauthorized distribution of the manual or dispersal of its contents is strictly forbidden. This manual may not be reproduced in whole or in part by any means whatsoever without the expressed written permission of Magnetek.

Chapter 2.0: Disconnecting Means/Overcurrent Protection

Note: Magnetek recommends using the following Disconnecting Means and Overcurrent Protection Guidelines as published in the 2005 National Electrical Code, copyright 2004.

2.1: Disconnecting Means

2.1.(a): 610.31 Runway Conductor Disconnecting Means: A disconnecting means, having a continuous ampere rating not less than that computed in Sections 610.41(e) and (f), shall be provided between the runway contact conductors and the power supply. Such disconnecting means shall consist of a motor circuit switch, circuit breaker, or molded case switch.

This disconnecting means shall:

2.1.(a).(i): Be readily accessible and operate from the ground or floor level.

2.1.(a).(ii): Be arranged to be locked in the open position.

2.1.(a).(iii): Open all ungrounded conductors simultaneously.

2.1.(a).(iv): Be placed within view of the crane or hoist, and the runway contact conductors.

2.2: **610.32 Disconnecting Means for Crane and Monorail Hoists:** A motor circuit switch or circuit breaker, arranged to be locked in the open position, shall be provided in the leads from the runway contact conductors or other power supply on all cranes and monorail hoists. Where disconnecting means is not readily accessible from the crane or monorail hoist operating station, means shall be provided at the operating station to open the power circuit to all motors of the crane or monorail hoists.

2.3: **610.33 Rating of Disconnecting Means:** The continuous ampere rating of the switch or circuit breaker, required by Section 610.32, shall not be less than 50 percent of the combined short-time ampere rating of the motors, or less than 75 percent of the sum of the short-time ampere rating of the motors required for any single motion.

2.4: Overcurrent Protection

The use of overcurrent Protection shall be provided in accordance with NEC Standard 610.41 through 610.43. Excerpts are from 2005 National Electrical Code, copyright 2004.

2.5: **610-41. Feeders, Runway Conductors:**

2.5.(a).(i): Single Feeder. The runway supply conductors and main contact conductors of a crane or monorail shall be protected by an overcurrent device(s) that shall not be greater than the largest rating or setting of any branch circuit protective device, plus the sum of the nameplate ratings of all the other loads with application of the demand factors from Table 610-14(e).

2.5.(a).(ii): More Than One feeder Circuit. Where more than one feeder circuit is installed to supply runway conductors, each feeder circuit shall be sized and protected in compliance with 610.41(A).

2.6: **610-42 Branch-Circuit, Short Circuit Ground Fault Protection.** Branch circuits shall be protected in accordance with 610.42(A). Branch-circuit taps, where made, shall comply with 610-42(B).

2.6.(a).(i): Fuse or Circuit Breaker Rating. Crane, hoist, and monorail hoist motor branch circuits shall be protected by fuses or inverse-time circuit breakers having a rating in accordance with Table 430.52. Where two or more motors operate a single motion, the sum of their nameplate current ratings shall be considered as that of a single motor.

2.6.(a).(ii): Taps.

(1) Multiple Motors. Where two or more motors are connected to the same branch circuit, each tap conductor to an individual motor shall have an ampacity not less than one-third that of the branch circuit. Each motor shall be protected from overload according to 610.43.

(2) Control Circuits. Where taps to control circuits originate on the load side of a branch-circuit protective device, each tap and piece of equipment shall be protected in accordance with 430.72.

(3) Brake Coils. Taps without separate overcurrent protection shall be permitted to brake coils.

2.7: **610.43 Motor and Branch-Circuit Overload Protection:** Each motor, motor controller, and branch-circuit conductor shall be protected from overload by one of the following means:

2.7.(a).(i): A single motor shall be considered as protected where the branch-circuit overcurrent device meets the rating requirement of Section 610.42.

2.7.(a).(ii): Overload relay elements in each ungrounded circuit conductor, with all relay elements protected from short circuit by the branch-circuit protection.

2.7.(a).(iii): Thermal sensing devices, sensitive to motor temperature or to temperature and current, that is thermally in contact with the motor winding(s). A hoist or trolley shall be considered to be protected if the sensing device is connected in the hoist's upper limit switch circuit so as to prevent further hoisting during an overload condition of either motor.

Note: Please reference the National Electrical Code (NEC) for exemptions or additional information on disconnecting means and overcurrent protection.

Chapter 3.0: Assembly Guidelines

3.1: System *without* Expansions

The following are general system installation guidelines; see the following sections for specific component installation instructions.

3.1.(a): Check alignment of mounting brackets prior to assembling hangers and bar. Correct any brackets that are misaligned. Mounting brackets should not exceed $\frac{1}{4}$ " in horizontal and vertical mis-alignment over 5'0" mounting centers.

3.1.(b): To expedite assembly, it is recommended that the hanger brackets be loosely assembled to the mounting brackets prior to hanging the mounting brackets.

3.1.(c): Anchor hangers are located on each of the first mounting brackets on either side of the centerline/joint.

3.1.(d): Locate the end of a bar (joint) approximately 2½ feet from a hanger – this will prevent joint/hanger interference as the system is assembled.

3.1.(e): From the center of the run – slide an anchor hanger on the conductor bar, and snap the end of the bar away from the centerline into the hangers.

3.1.(f): Locate bar in appropriate position on the mounting brackets and tighten the anchor hangers/snap-in hangers to the mounting brackets.

3.1.(g): Add the additional number of conductors to fill the snap-in hangers. Remember, if single hangers are used, space the hangers equal to the center-to-center dimension of the snap-in hanger before tightening to mounting bracket/bar.

3.1.(h): Continue to mount bar in one direction from center, applying conductors to the end of those previously assembled.

3.1.(i): Between each individual bar a joint and a joint cover must be mounted. When assembling a joint, the following items should be checked:

3.1.(i).(i): The end of the conductor bars are located tightly close to each other (never to exceed $\frac{1}{8}$ " gap).

3.1.(i).(ii): The joint assembly is centered over the end of each bar.

3.1.(i).(iii): The joint is appropriately tightened and checked prior to installing the joint cover.

3.1.(i).(iv): Open each end cover on the joint cover and remove the packaging foam. Mount over joint, prior to closing the end covers. Verify the centering tabs and the bottom of the cover are located between the end of each conductor cover and clear of collector slot.

3.1.(j): Power feeds are designed to be mounted at system joint locations. Ensure that the hardware is tightened appropriately and the power feed cover is properly located on the bar. Be sure feed cables do not apply any additional stress on the conductor bars.

3.1.(k): At the end of each conductor run, end caps are needed to properly insulate the system.

3.1.(l): Return to the center of the system and continue to assemble in the other direction.

3.1.(m): Collectors: Check that mounting post is an equal distance vertically from each conductor bar. This will provide equal tension per collector. Each collector is to be centered on the conductor on which it is to travel.

3.2: System *with* Expansions

The following are general system installation guidelines; see the following sections for specific component installation instructions.

3.2.(a): Check alignment of mounting brackets prior to assembling hangers and bar. Correct any brackets that are misaligned. Mounting brackets should not exceed ¼" in horizontal and vertical mis-alignment over 5'0" mounting centers.

3.2.(b): To expedite assembly, it is recommended that the hanger brackets be loosely assembled to the mounting brackets prior to hanging the mounting brackets.

3.2.(c): Anchor hangers will be located on mounting brackets: 120 ft. from the centerline of the expansion assembly on 90 Amp and 110/125 Amp systems; 80 ft. from the centerline of the expansion assembly on 250 Amp and 400 Amp systems.

3.2.(d): Begin system assembly by installing the expansion assemblies or the first set of expansion assemblies. Locate the end of the expansion (joint) approximately 2½ ft. from a hanger – this will prevent joint/hanger interference as the system is assembled.

3.2.(e): Once the first set of expansion assemblies are assembled to the mounting brackets, begin to assemble additional conductors to the system in one direction from the expansion.

3.2.(f): The expansion gap will need to be set as per the chart located on page 17. Note: Set gap to the appropriate dimension. This will need to be verified prior to clamping the anchor hangers.

3.2.(g): Continue to assemble the system in one direction through the anchor hangers (do not tighten at this time) to the end or to the next expansion assembly.

3.2.(h): Between each individual bar, a joint and a joint cover must be mounted. When assembling a joint, the following items should be checked:

3.2.(i).(i): The ends of the conductor bars are located tightly close to each other (never to exceed 1/8" gap).

3.2.(i).(ii): The joint assembly is centered over the end of each bar.

3.2.(i).(iii): The joint is appropriately tightened and checked prior to installing the joint cover.

3.2.(j): Open each end cover on the joint cover and remove the packaging foam. Mount over joint, prior to closing the end covers. Verify the centering tabs and the bottom of the cover are located between the end of each conductor cover and clear the collector slot.

3.2.(k): Power feeds are designed to be mounted at system joint locations. Ensure that the hardware is tightened appropriately and the power feed cover is properly located on the bar. Be sure feed cables do not apply any additional stress on the conductor bars.

3.2.(l): From the other end of the initial expansion assemblies installed, continue to install the system in the other direction.

3.2.(m): At the end of each conductor run, end caps are needed to properly insulate the system.

3.2.(n): With the system installed, except for the clamping of anchors to the bar, return to the first set of anchors located from the end of the conductor run and tighten the anchor hanger.

3.2.(o): Go to the first set of expansion assemblies located next to the previously tightened anchor hangers and confirm the expansion gap setting. Adjust if necessary.

3.2.(p): Go to the next anchor hanger on the other side of the expansion and tighten the anchor hangers against the bar. If there is more than one expansion area on the system, continue down the conductor run and repeat the above procedure.

3.2.(q): Confirm gap settings at each expansion location.

3.2.(r): Collectors: Check that mounting post is an equal distance vertically from each conductor bar. This will provide equal tension per collector. Each collector is to be centered on the conductor on which it is to travel.

Standard System Layout Without Expansion

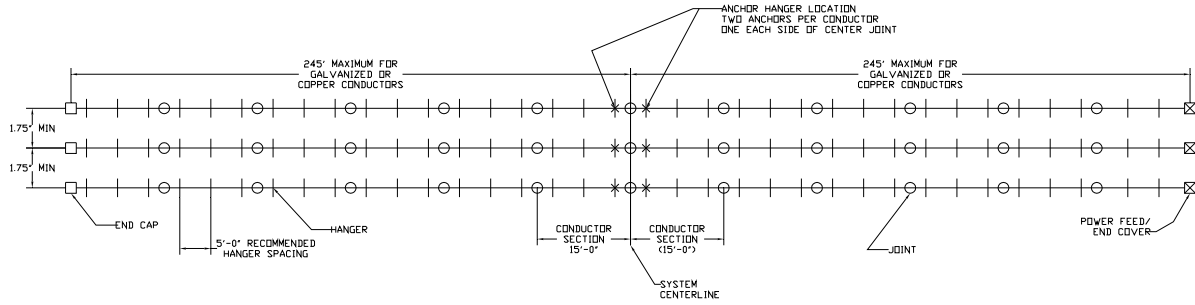

Standard System Layout With Multiple Expansions

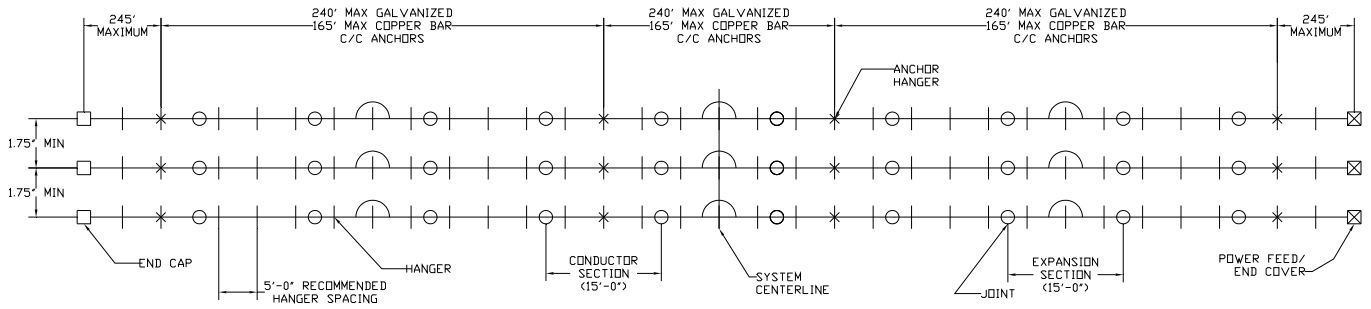

Chapter 4.0: Modular Hangers

4.1: FS-H2, FS-H3, FS-H3L, FS-H4

4.1.(a): Remove nut(s), lock washer(s) and flat washer(s) from hanger base mounting bolt(s).

4.1.(b): Assemble hanger base to mounting bracket by inserting hanger bolt(s) through mounting bracket hole(s).

4.1.(c): Assemble washer(s), lock washer(s) and bolt(s) to hanger bolt(s) and hand tighten.

4.1.(d): Assemble the snap-in hangers to the hanger base. Locate and follow the arrows on the sides of the hangers to properly install to the base. **NOTE: INDIVIDUAL HANGERS ARE NOT RE-USABLE; IF REMOVED FROM THE BASE, IT SHOULD BE REPLACED.**

4.1.(e): Snap line elements into the snap-in-hangers.

4.1.(f): Verify the alignment of the system and tighten the nut 15 to 19 lb.ft.

Note: Tools Required: ½" Wrench or Socket

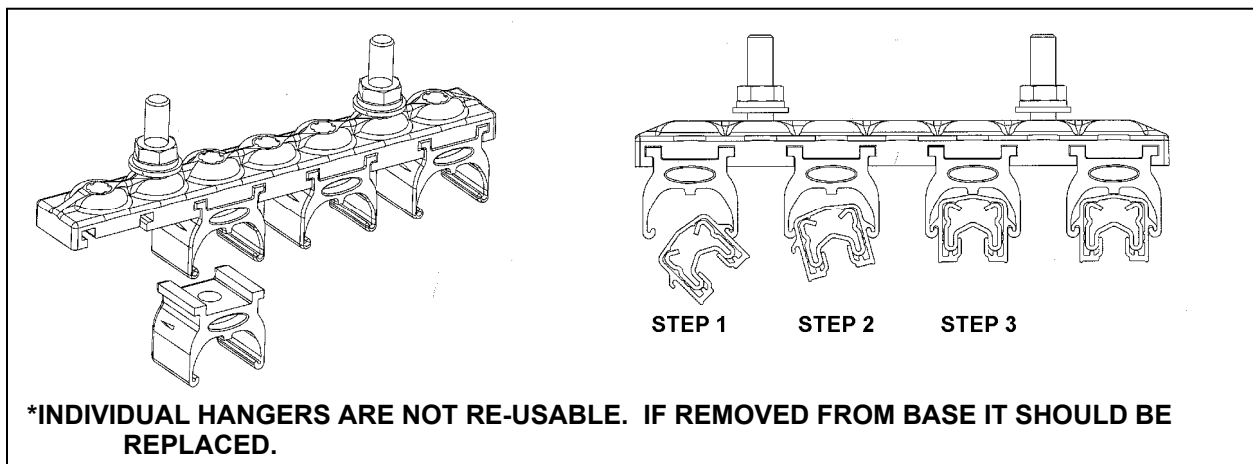

4.2: Mounting Centers

4.2.(a): Standard centers for hanger installation are 5'0" on horizontal and vertical systems.

4.3: Single Mounting Hangers (FS-SH, FS-HST)

4.3.(a): Remove nut, lock washer and flat washer from hanger base mounting bolt.

4.3.(b): Assemble hanger base to mounting bracket by inserting hanger bolt through mounting bracket hole (NOTE: Minimum spacing of 1.75").

4.3.(c): Assemble washer, lock washer and bolt to hanger base bolt and hand tighten.

4.3.(d): Snap line elements into the snap-in-hangers.

4.3.(e): Verify the alignment of the systems and tighten the nut 15 to 19 lb.ft.

Note: Tools Required: ½" Wrench or Socket

4.4: Anchor Hanger (FS-AH)

4.4.(a): Slide anchor hanger assembly over the end of the line element near the mounting bracket.

Note: Slide the anchor hangers on the line element, with the clamping nut of the hanger facing the outside of the system, for ease of installation.

4.4.(b): Remove nut, lock washer and flat washer from anchor hanger mounting bolt.

4.4.(c): Snap the line elements into the snap-in hangers located next to the anchor hanger location.

4.4.(d): Insert anchor hanger mounting bolt through the mounting bracket.

4.4.(e): Assemble washer, lock washer and bolt to hanger base bolt and hand tighten.

4.4.(f): Tighten anchor hanger clamping nut 8 to 10 lb.ft. (do not over-tighten).

4.4.(g): Verify alignment and tighten nut of mounting bolt 15 to 19 lb.ft.

Note: Tools Required: ½" Wrench or Socket and 7/16" Wrench

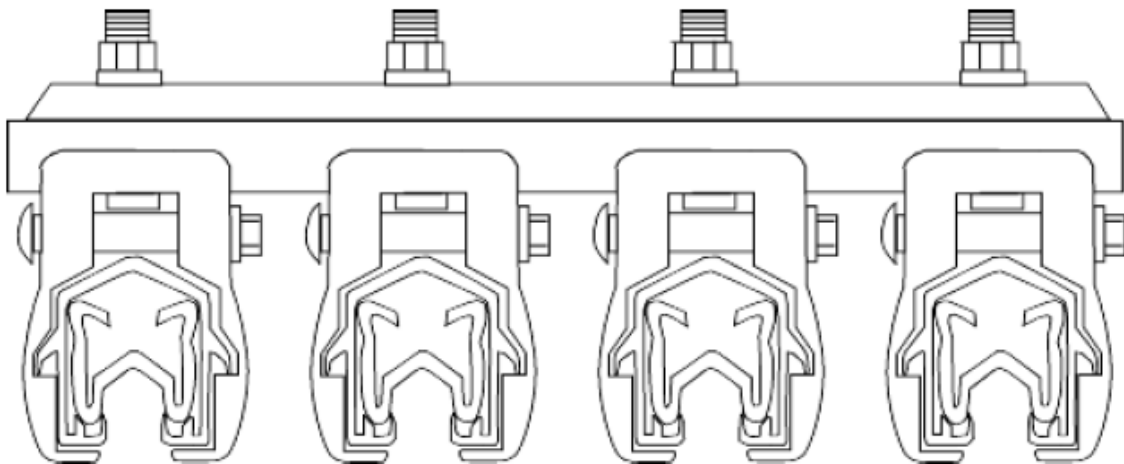

Chapter 5.0: Joint Assembly

5.1: FS-JNTG, FS-JNTC

5.1.(a): Verify that the clamping plate is 1/8" below the underside of the joint assembly bracket. If not, loosen or tighten the nuts to make the adjustment.

5.1.(b): Slide the joint assembly into upper slot of the end of the line element. Be sure the clamping plate is properly located in the end of the line element.

5.1.(c): Slide the next line element into the open end of the joint assembly. Be sure the clamping plate is properly located in the end of the line element.

5.1.(d): Center joint assembly over the adjoining line elements.

5.1.(e): Tighten one nut of the joint assembly 4.6 to 5.8 lb.ft.

5.1.(f): Verify the end face of each line element is together.

5.1.(g): Tighten the other nut of the joint assembly 4.6 to 5.8 lb.ft.

5.1.(h): Verify each nut on joint is tightened appropriately.

Note: Tools Required: 3/8" Wrench or Socket

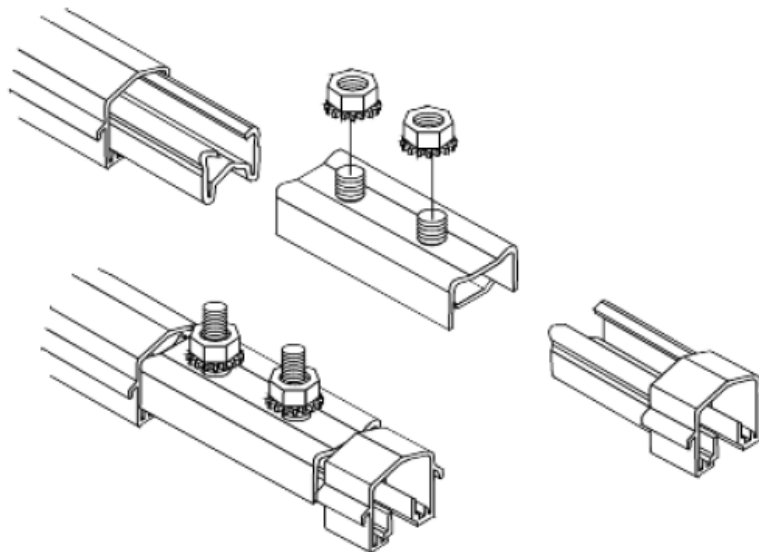

Note: A liberal coating of joint compound FS-JNJC is recommended on all mating faces that conduct current.

5.2: Joint Covers (FS-JNCV)

5.2.(a): Open joint end cover on each end of the joint (disengage lower locking tabs from each side of cover).

5.2.(b): Remove packaging foam.

5.2.(c): Center joint cover over joint assembly.

5.2.(d): With light pressure, open the bottom of the joint cover sufficient to clear the sides of the line element. Damage may occur to joint cover if it is spread beyond 1¼" wide.

5.2.(e): Push joint cover down until lower lips of cover clear the bottom of the line element. If cover does not clear bottom of line element, verify the cover is centered between joint assembly bolts.

5.2.(f): Push on sides of joint cover so lips are positioned under the line elements.

5.2.(g): Pull up on the joint cover so the lips are in contact with bottom of the line element cover and insulate the vertical face of the exposed conductor bar.

5.2.(h): Fold down flaps at each end of the joint cover.

5.2.(i): Fold the locking tabs around the side of the joint cover and snap them into the slots along the side of the joint cover.

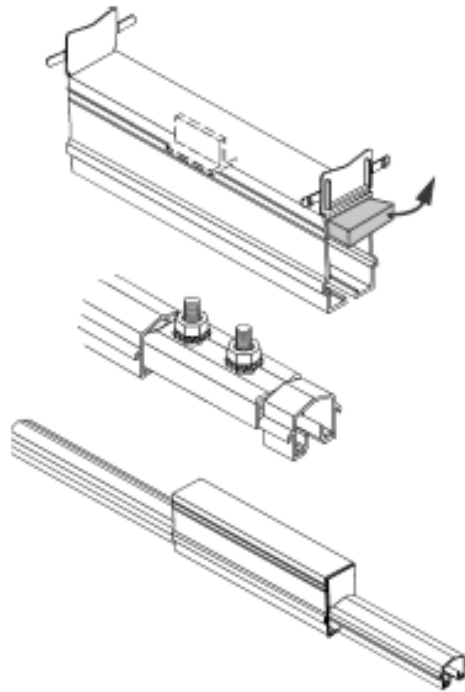

5.3: End Cover (FS-END)

5.3.(a): Verify that the clamping plate is 1/8" below the underside of the end joint connector. If it is not, loosen or tighten the nuts to make the adjustment.

5.3.(b): Slide end cap hardware into slot at end of the line element.

5.3.(c): Push end cap hardware until it comes in contact with the conductor bar cover, and tighten the nut 4.6 to 5.8 lb.ft.

5.3.(d): Push the end cover boot over the end of the bar and end cap hardware. Manipulate end cover boot until the nut relief in the boot is directly over the end cap hardware.

The boot may become less pliable in low ambient temperature installation. Keeping the boot in a warm location (+65°F) until needed is recommended.

Note: Tools Required: 3/8" Wrench or Socket

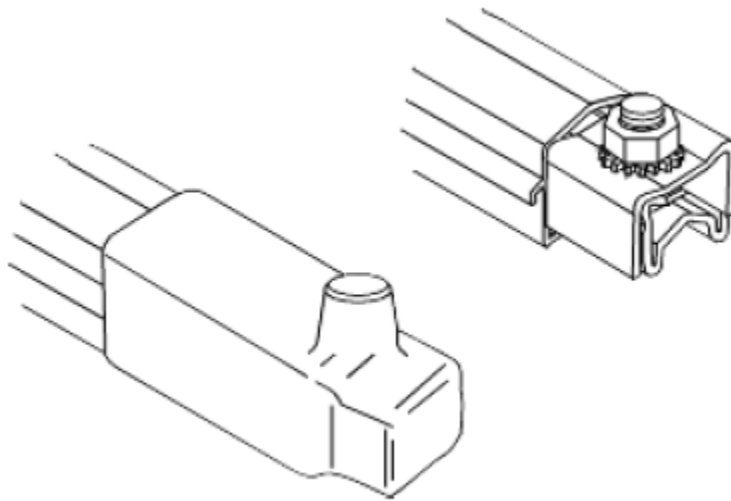

Chapter 6.0: Electrobar FS Expansion Elements

6.1: Galvanized Steel Elements (90A and 110A)

6.1.(a): Systems not exceeding 490' do not require expansion elements when installed with an anchor hanger at the center of the line. In systems that are longer than 490', expansions are needed every 240', based on 100°F range in ambient temperature during the year.

6.2: Copper Elements (250A and 400A)

6.2.(a): Systems not exceeding 490' do not require expansion elements when installed with an anchor hanger at the center of the line. In systems that are longer than 490', expansions are needed every 165', based on a 100°F range in ambient temperature during the year.

FINGERSAFE BAR					
90 Amp, 110 Amp & 125 Amp Galvanized Steel Conductors			250 Amp & 400 Amp Copper Conductors		
Conductor Length	Anchors Required	Expansions Required	Conductor Length	Anchors Required	Expansions Required
Up to 490'	2*	0	Up to 490'	2*	0
491' to 730'	3	2	491' to 650'	4	3
731' to 970'	4	3	651' to 810'	5	4
971' to 1210'	5	4	811' to 970'	6	5
			971' to 1130'	7	6

* Install one set of anchors on each side of center Joint Assembly.

Note: Additional expansions may be required for outdoor applications, please consult the factory.

6.3: Expansion Assembly Installation

6.3.(a): Allow sufficient time for the line elements to equalize to the ambient temperature of 77°F within the installation area. Then locate the expansion assemblies, which consist of three separate pieces:

6.3.(a).(i): 5' expansion assembly

6.3.(a).(ii): 10' length of conductor bar

6.3.(a).(iii): Joint assembly

6.3.(b): Assemble the 5' expansion assembly to the 10' length of conductor bar, using the joint assembly to complete the 15' expansion.

6.3.(c): If the expansion assemblies need to be staggered, simply rotate the assembly 180 degrees prior to installation.

6.3.(d): Insert the expansion at required locations along the runway.

6.3.(e): Expansion is to be supported by a mounting bracket, at the center point of the bridging bracket, located directly over the expansion point.

6.3.(f): Standard Hangers to be installed at 5' 0" centers along the system.

6.3.(g): Set and hold appropriate gap while installing the expansion.

Note: Tools Required: 3/8" Wrench or Socket

6.4: Expansion Gap Settings

Note: Failure to pre-set the air gap correctly could cause buckling of the conductors. Each expansion section must have a gap set at the time of installation. Refer to the following table for the appropriate settings.

Range of Air Temperatures During the Year	Air Temperature During Installation, With Bar at Air Temperature	Gap Width Setting
0° F to 100° F	25° F	1 3/4"
	50° F	1 1/4"
	75° F	3/4"
25° F to 125° F	50° F	1 3/4"
	75° F	1 1/4"
	100° F	3/4"
50° F to 150° F	75° F	1 3/4"
	100° F	1 1/4"
	125° F	3/4"

Chapter 7.0: Power Feed Wire/Connection

7.1: Power feed cables must be sized to meet the ampere demands of the line element and be connected to the power feed assembly by using a properly sized and crimped ring terminal.

See below for typical feed cables and ring terminals.

Line Element Size	Ring Terminal	Min. Cable Size*
90 Amp	S4-10R0-E	4 AWG
110 Amp	S2-10R-X	2 AWG
125 Amp	S2-10R-X	2 AWG
250 Amp	S3-0-38R-5	#3/0
400 Amp	S250-38R-5	250 MCM

*Reference NEC Table 610.14 for minimum cable sizing.

Note A: Tubular ring terminals listed are Panduit type and are shown only to illustrate the type of ring required. Any terminal connectors may be used as long as it is properly sized.

Note B: Check local electrical codes for any additional specifications and/or restrictions.

Note C: A liberal coating of joint compound is recommended on all mating faces that conduct current.

Note D: Power feed cables must be supported from the top to prevent vertical loading on the conductor bar.

7.2: 90/110/125 Amp In-Line Power Feed Assembly (FS-PFB)

7.2.(a): Verify that the clamping plate is 1/8" below the underside of the joint assembly bracket. If it is not, loosen or tighten the nuts to make the adjustment.

7.2.(b): Slide the joint assembly into the upper slot of the end of the line element. Be sure the clamping plate is properly located in the end of the joint assembly.

7.2.(c): Slide the next line element into the open end of the joint assembly. Be sure the clamping plate is properly located in the end of the line element.

7.2.(d): Center joint assembly over the adjoining line elements.

7.2.(e): Tighten one nut of the joint assembly 4.6 to 5.8 lb.ft.

7.2.(f): Verify the end face of each line element is together.

7.2.(g): Tighten the other nut of the joint assembly 4.6 to 5.8 lb.ft.

7.2.(h): Assemble power feed wire to one lug of the power feed assembly, using an appropriate terminal connector. Feed power feed wire through end of power feed cover before attaching the power feed cover to the joint.

7.2.(i): Assemble nut to lug and tighten to a maximum of 5.8 lb.ft.

7.2.(j): Assemble the power feed cover over the power feed. Reference the joint cover instructions.

Note: Tools Required: 3/8" Wrench or Socket

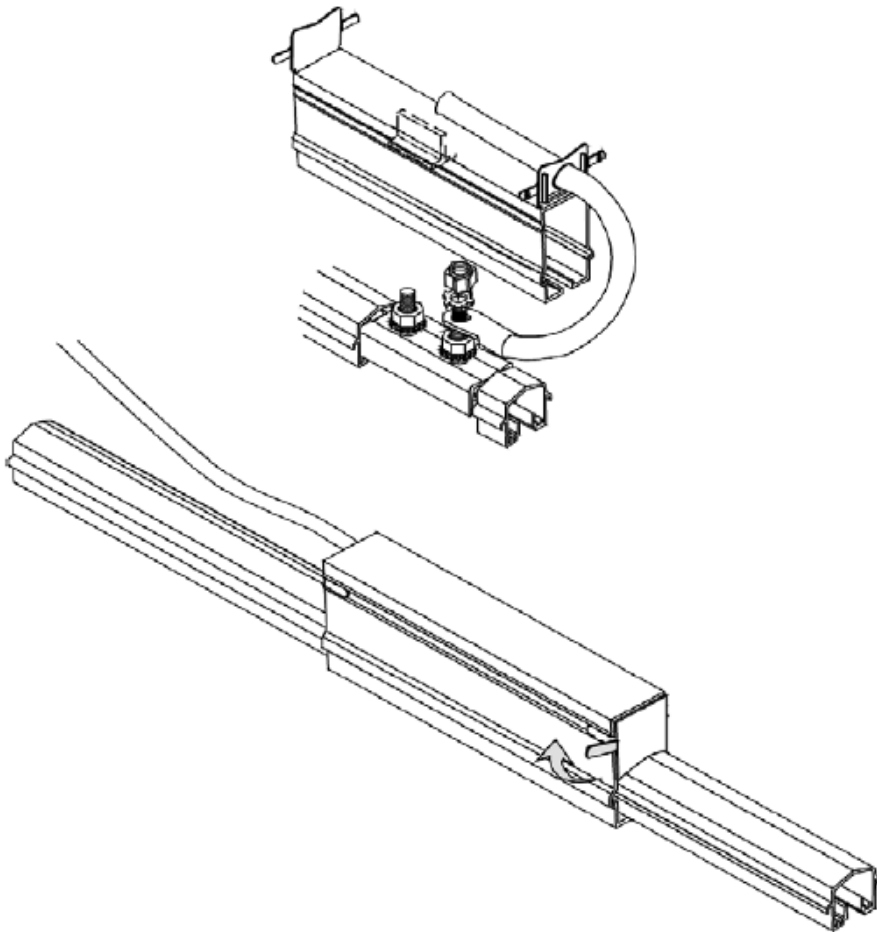

Note: A liberal coating of joint compound, FS-JNJC, is recommended on all mating faces that conduct current.

Note: To use the in-line power feed as an end-line power feed assembly, see page 22 for instructions.

7.3: 250/400 Amp In-Line Power Feed Assembly (FS-PFC)

7.3.(a): Remove both nuts on the top side of the power feed base (joint connector). Verify that the clamping plate is 1/8" below the underside of the joint assembly bracket.

7.3.(b): Slide the joint assembly into the upper slot of the end of the line element. Be sure the clamping plate is properly located in the end of the line element.

7.3.(c): Slide the next line element into the open end of the joint assembly. Be sure the clamping plate is properly located in the end of the line element.

7.3.(d): Center joint assembly over the adjoining line elements.

7.3.(e): Slide the power feed bracket over the stud to the power feed base (joint connector) and thread the nuts to the threaded studs.

7.3.(f): Tighten one nut of the power feed base (joint assembly 4.6 to 5.8 lb.ft.).

7.3.(g): Verify the end face of each line element is together.

7.3.(h): Tighten the other nut of the power feed base (joint assembly 4.6 to 5.8 lb.ft.).

7.3.(i): Assemble power feed wire to one lug of the power feed bracket using an appropriate terminal connector.

7.3.(j): Assemble nut to power feed bracket carriage bolt and tighten 26 to 33 lb.ft.

7.3.(k): Slide the power feed cover half up from the bottom of the conductor bar. Pull up on the power feed cover half so the lower lips are in contact with the bottom of the line element cover and insulate the vertical face of the exposed conductor bar.

7.3.(l): Repeat with the other half. Align cable with cable opening on appropriate side of power feed cover.

7.3.(m): Insert the four cover screws and tighten.

7.3.(n): Attach wire ties over each end of power feed cover and tighten-remove excess.

7.3.(o): Insert red power feed cover plug into end of cover without cable.

Note: Tools Required:
3/8" Wrench or Socket
9/16" Wrench or Socket
Flat Head Screwdriver (small)

Note: A liberal coating of joint compound, FS-JNJC, is recommended on all mating faces that conduct current.

Note: To use in-line power feed as end-line power feed assembly, see page 22 for instructions.

250/400 Amp In-Line Power Feed Assembly

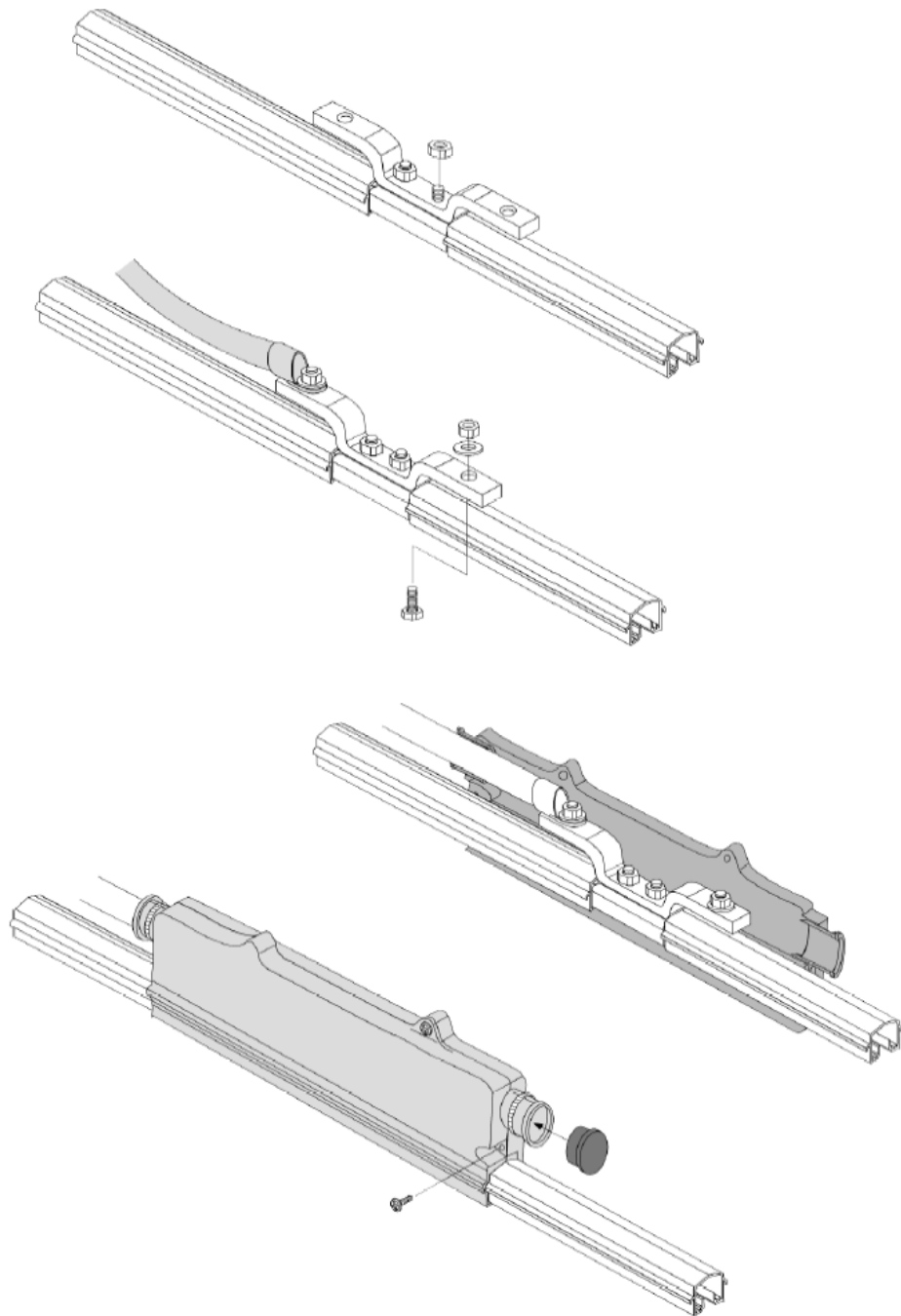

7.4: In-Line Power Feed Assembly For Use As End-Line Power Feed Assembly

7.4.(a): Slide cover of the line element back approximately 12 inches.

7.4.(b): Cut and remove 10" of the cover protruding from the end of the line element. Slide the remaining cover back into place on the line element.

7.4.(c): Using the 10" section of cut cover, remove another 2" of cover to produce (1) 2" section and (1) 8" section. Discard the 2" section.

7.4.(d): Slide the joint assembly, from the In-Line Power Feed Kit, onto the end of the bar where the cover has been removed.

7.4.(e): Slide the 8" section of the cover onto the line element to meet the Joint Assembly. The line element should now look like a standard piece with a Joint Assembly 10" from the end of the line element.

7.4.(f): Continue the In-Line Power feed Assembly according to the instructions on page 18 for 90/110/125 Amp systems, or page 20 for 250/400 Amp systems.

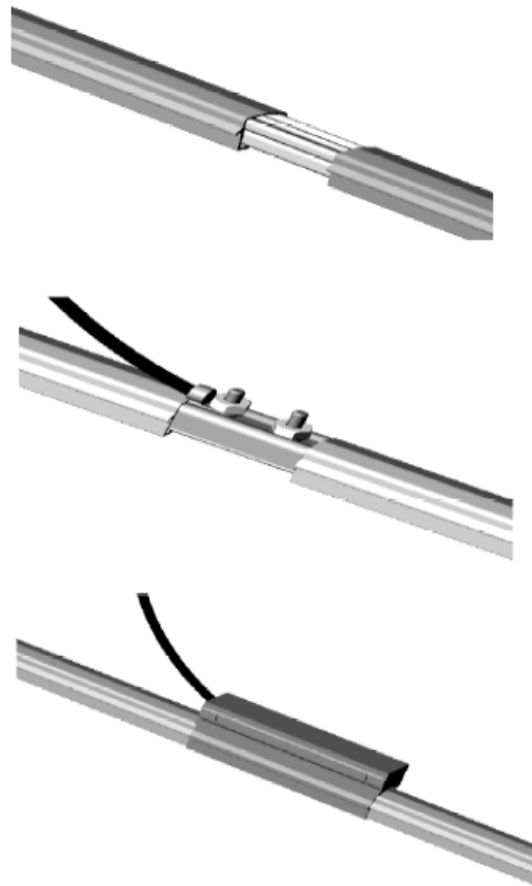

Chapter 8.0: Transfer Cap

8.1: FS-TCAP

8.1.(a): Be sure set screws provided are backed out and will not interfere with installation.

8.1.(b): Slide transfer cap over end of conductor bar. The transfer cap should slide 1-7/16" over the end of the bar (3/4" over the bar cover) until the bar stops against the inside of the cap.

8.1.(c): Tighten each set screw equally against the conductor bar; be sure the set screw is tightened a minimum 1/16" below the outer surface of the transfer cap.

8.1.(d): For best performance be sure the transfer caps are aligned as shown below.

Note: Tools Required: 3/32" Allen Wrench

Transfer Cap Alignment Specifications

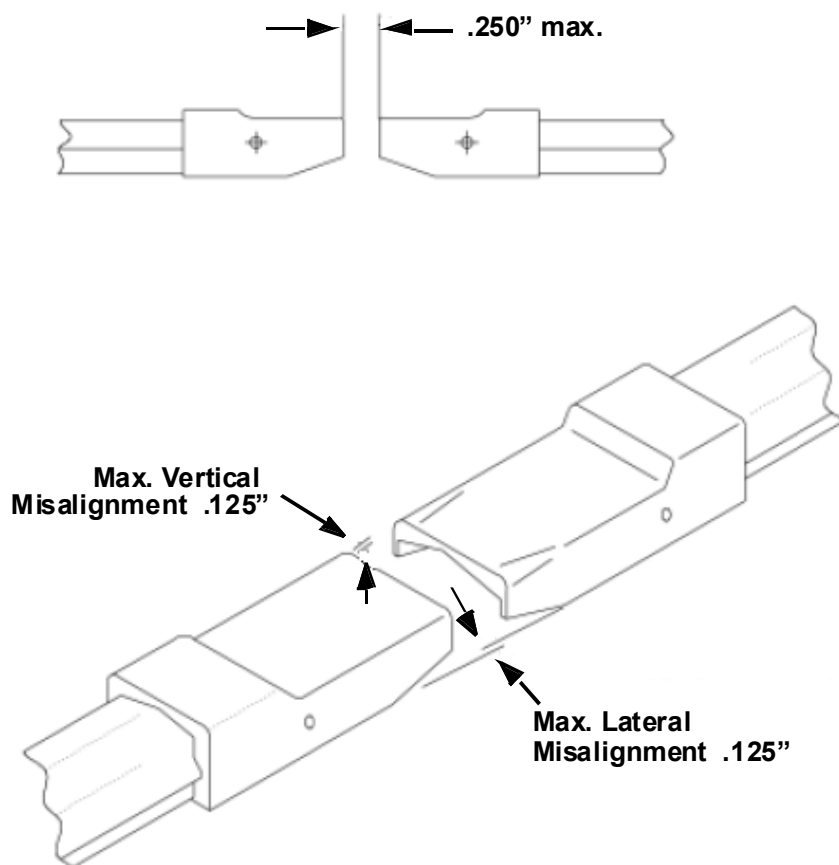

Chapter 9.0: Collectors

9.1: Mount the collector mounting post so the horizontal centerline of the post is $7" \pm 0.75"$ from the running surface of the conductor bar.

9.1.(a): Slide each of the collectors onto the mounting post until they are directly under the conductor bar it is going to run in.

Note: When mounting tandem collectors, be sure each collector shoe is positioned in the appropriate conductor bar.

9.1.(b): Tighten each bolt (upper and lower) until the collector is firmly in place (10 lbs.ft.).

9.1.(c): Termination of collector leads should be in accordance with NEC and local electrical standards.

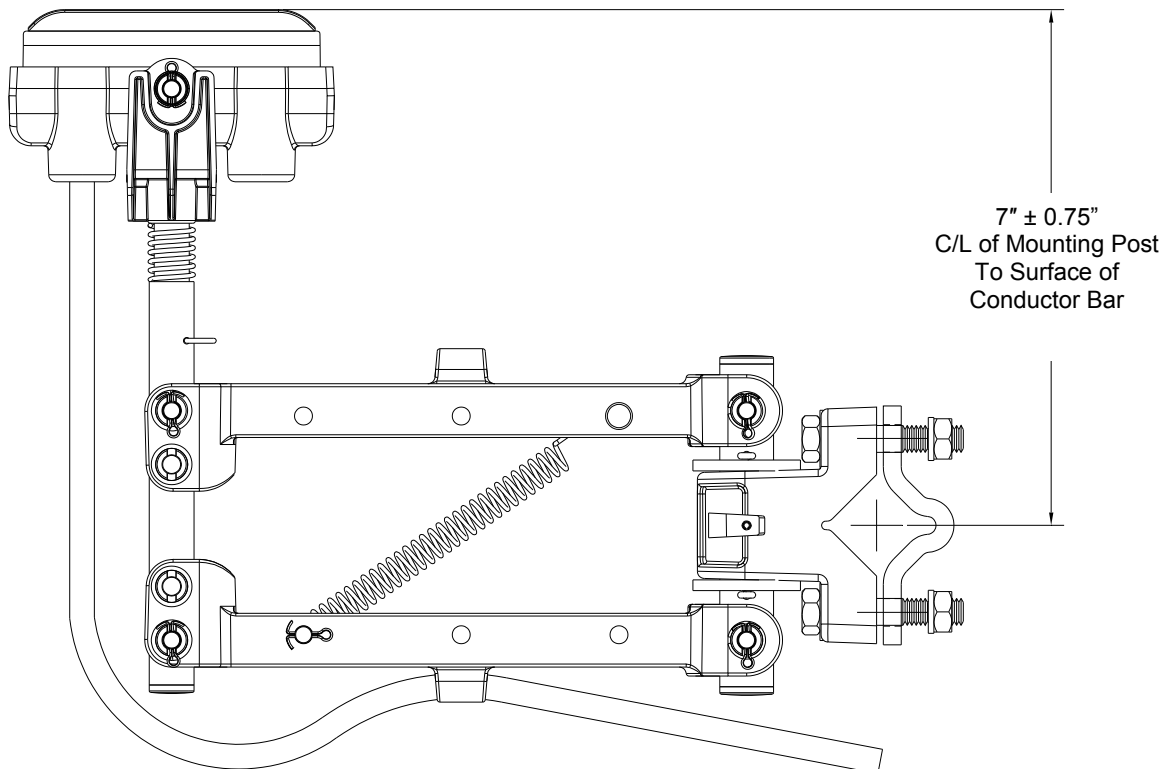

Note: Before performing any maintenance on the system, be sure that the power to the system has been disconnected following lock-out tag-out procedures.

9.2: If installing or replacing collectors on an existing collector mounting post with the horizontal centerline of the existing post 3.50" to 4.50" from the running surface of the conductor bar, an extension bracket must be installed with the collector.

9.2.(a): Slide the collector onto the mounting post until it is directly under the conductor it will run in.

NOTE: When mounting tandem collectors, be sure each collector shoe is matched to the appropriate conductor.

9.2.(b): Tighten each bolt until the collector is firmly in place on the mounting post (10 lbs.ft.).
Note: The size of the mounting posts may vary – if the extension bracket does not tighten firmly against the mounting post after the bolts are tightened, remove the bolt from above the post, remove the spacer washer, replace the bolt and re-tighten.

9.2.(c): Termination of the collector leads should be in accordance with NEC and local electrical standards.

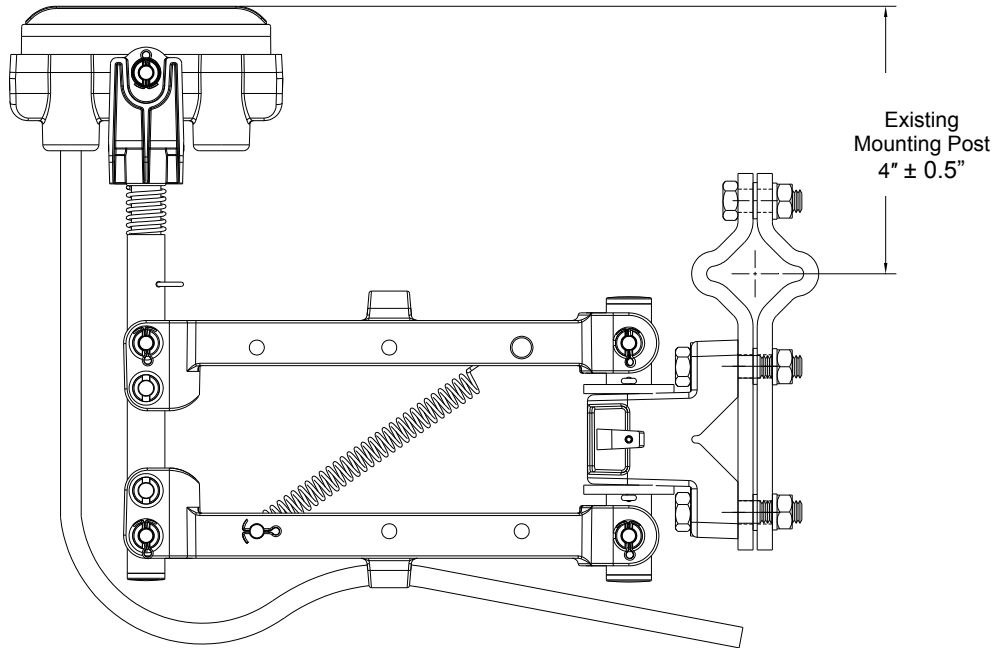

If replacing a single existing collector that is not on the outermost side of the mounting post, it is recommended that the existing collectors are loosened and removed so the new collector can be slid on over the mounting post.

9.3: Collector Shoe Replacement

9.3.(a): Pivot the head assembly away from the bar. Remove the cotter pin from the head pivot pin and then remove the pivot pin.

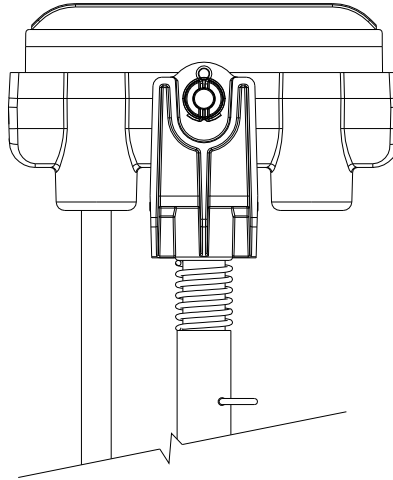

9.3.(b): Remove collector head assembly from the collector. To remove the shoe, insert a small flat-headed screwdriver into the slot on the end of the shoe holder and pivot downward.

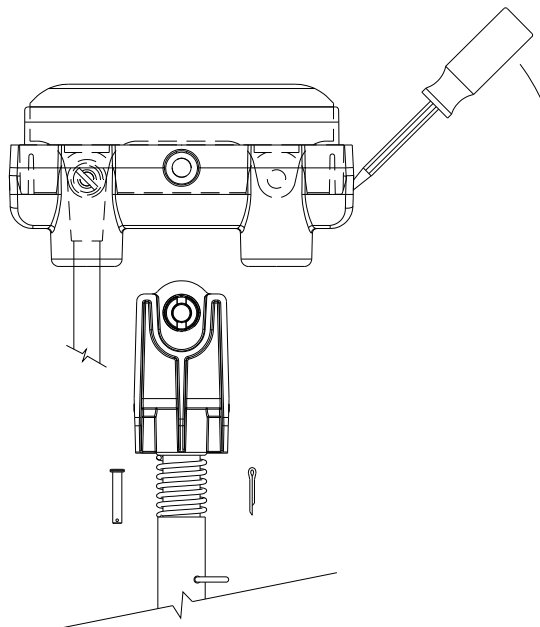

9.3.(c): Slide the shoe sleeve from the shoe holder.

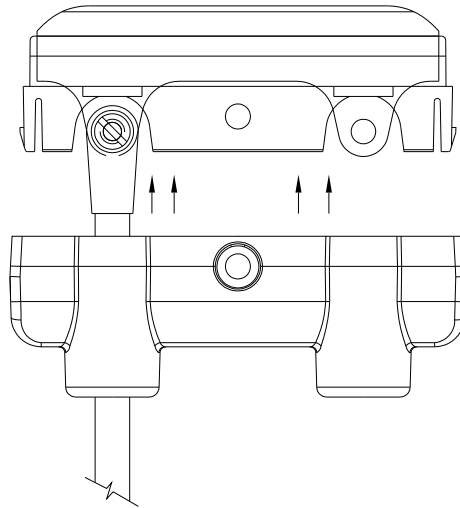

9.3.(d): Remove connector hardware from the collector shoe and discard worn collector shoe.

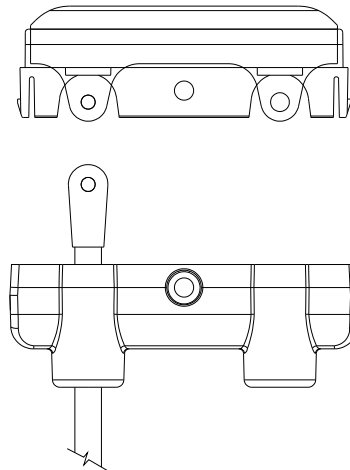

9.3.(e): Visually inspect feed cable for any cuts or wear, and replace if necessary. Assemble feed cable to the collector shoe as shown. Push the collector shoe straight into the shoe holder until the shoe sleeve snaps into the shoe holder.

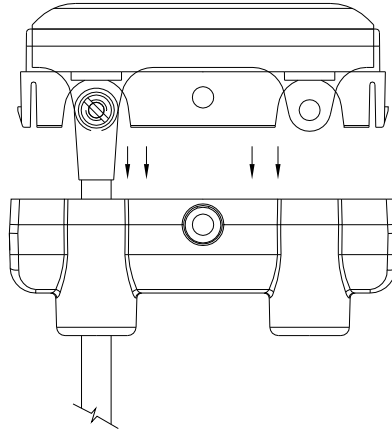

9.3.(f): Re-assemble the collector head assembly to the collector with pivot pin and cotter pin. Re-position the shoe into the appropriate conductor.

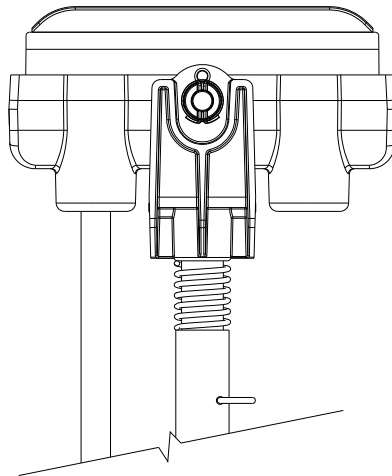

Chapter 10.0: Final Inspection

10.1: Final inspection of all components should be made, including the following important items:

10.1.(a): Make sure the conductor bar runs are straight. Adjust any hanger clamps, which are not straight, and replace any conductor bar which may have been bent or damaged.

10.1.(b): No HOT (electrically energized) bare metal parts should be exposed. Make sure insulating covers, joint covers, power feed covers, and end covers are securely in place to prevent any accidental contact by personnel.

10.1.(c): Run the equipment back and forth several times along the entire system length to make sure the system functions properly.

10.1.(d): File any conductor joints that are uneven or not smooth.

10.1.(e): Make sure the conductors are able to float, except at anchor points, to allow for expansion and contraction due to temperature variations.

10.1.(f): Make sure there is no excessive ambient heat. Heat shields may need to be installed near furnaces, etc.

10.1.(g): Make sure that the system is protected from falling objects and water.