

<b>CHESTER HOIST</b>	Service Instructions and Maintenance Manual	<b>IMPORTANT</b>
<b>ARMY TYPE HOIST</b>		
Keep for Future Reference		

**SERVICE INSTRUCTIONS AND MAINTENANCE MANUAL**

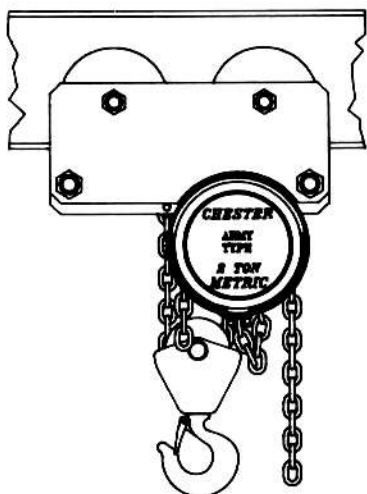

**1½ & 2 METRIC TON**

**CAUTION:**

**THE EQUIPMENT ILLUSTRATED AND DESCRIBED IN THIS BULLETIN IS DESIGNED FOR MANUAL OPERATION ONLY AND IS NOT TO BE POWER DRIVEN, NOR IS IT SUITABLE FOR LIFTING PEOPLE.**

**NOTE:** Before operating this hoist read ANSI B30.16 Safety Standard for Overhead Hoists and this manual. Make this information available to all persons who will install, operate or maintain this equipment.

**INSTALLATION ON RUNWAY BEAM**

Before placing the unit on its runway beam check the spacing between the vertical wheel flanges of the trolley. This spacing should be  $\frac{1}{16}$ " to  $\frac{1}{8}$ " wider than the width of the beam for proper operation. Adjust this spacing by moving the adjustment washers as required. Always center the hoist load bar between the trolley side plates.

**HOIST MAINTENANCE**

Under normal operating conditions the Chester Army Type hoist requires no routine maintenance. However, periodic inspection on a regular basis is essential to continued safe operation of any hoist. Refer to the Inspection section of this manual for specific inspection instructions.

**HOIST LUBRICATION**

Ordinarily only the load chain of the hoist will require regular lubrication. The hoist has been factory lubricated and tested. Under normal conditions this lubrication will last the lifetime of the hoist. However, extreme conditions or duty cycles may create the need to relubricate the hoist. Should this occur the lubrication can be restored as recommended below.

1. Brake Mechanism — Never lubricate the brake discs or the adjacent brake surfaces. Regrease the pawl stud by removing the pawl and lightly coating the stud with a NLGI No. 2 grease. Apply a thin coating of a NLGI No. 2 grease to the internal thread on the hand chain wheel prior to reassembly.

2. Gear Mechanism — Generously coat the entire gear train including the pinion bearings with a NLGI No. 2 grease with an extreme pressure additive. If the hoist is disassembled renew the lubrication in the sintered bronze spindle bushings by coating them with an intermediate oil with an extreme pressure additive.
3. Load Shaft Bearings — These ball bearings are factory lubricated and sealed.
4. Load Chain — Useful load chain and load sprocket life can be extended by lubricating the load chain at frequent intervals. Oil the chain regularly with an intermediate oil with an extreme pressure additive. After lubrication, excess oil can be removed by wiping the outside of the chain with a rag.
5. Trolley Wheel Bearings — These ball bearings are factory lubricated and sealed.
6. Trolley Drive Pinion Block (Geared Units Only) — Relube this block with an NLGI No. 2 grease using the lube fitting provided.
7. Idler Sheave Bearings — These bearings are impregnated with oil. Renew this lubrication by coating the bearing with an intermediate oil with an extreme pressure additive.

## **INSPECTION**

Regular, periodic inspection is essential to continued safe operation of a hoist. Careful inspection, done on a regular basis, will reveal potentially hazardous conditions while still in the early stages. Inspection requirements and operating practices for overhead hoists are outlined in the ANSI B30.16 Specification. This specification should be used as a guide for setting up a formal inspection program for this hoist.

The following items should be inspected daily or before using the hoist.

1. Braking Mechanism — Check by lifting the load a short distance then lowering to its original position checking for slippage or free run.
2. Load Chain — For wear, twists, broken or otherwise damaged links. Chain should be clean and free of foreign material or excessive rust. Chain should be properly lubricated.
3. Hooks — For wear, heavy nicks, cracks or deformation. The hook must turn freely and the hook latch must be operative.

**NOTE:** Any hook that is twisted or has a throat opening in excess of normal indicates the hoist has been extremely overloaded and abused. These conditions require an inspection of all other load bearing components of the hoist for damage.

## **ORDERING REPLACEMENT PARTS**

If replacement parts are needed refer to the parts lists included in this manual. To order parts supply the following information.

1. Hoist Serial Number
2. Part Number of Needed Part(s)
3. Quantity Needed

# 1 1/2 & 2 METRIC TON ARMY TYPE HOIST

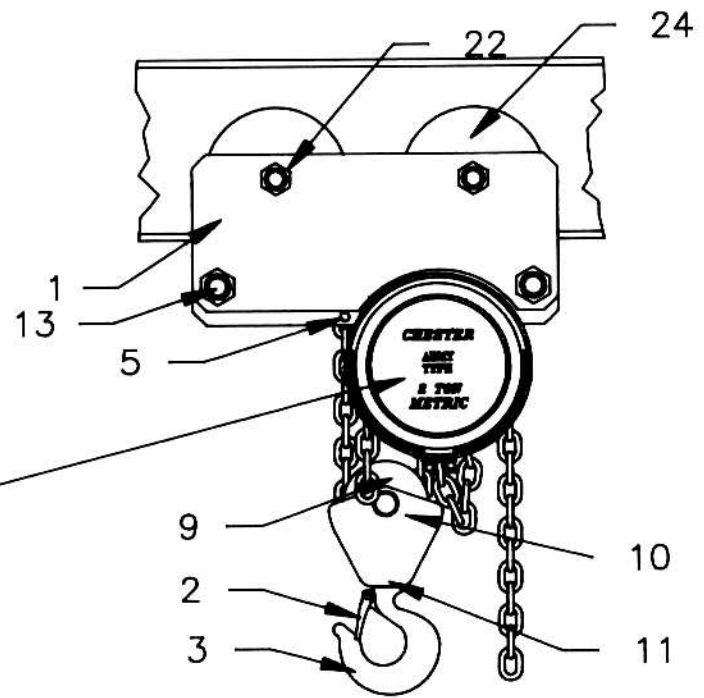
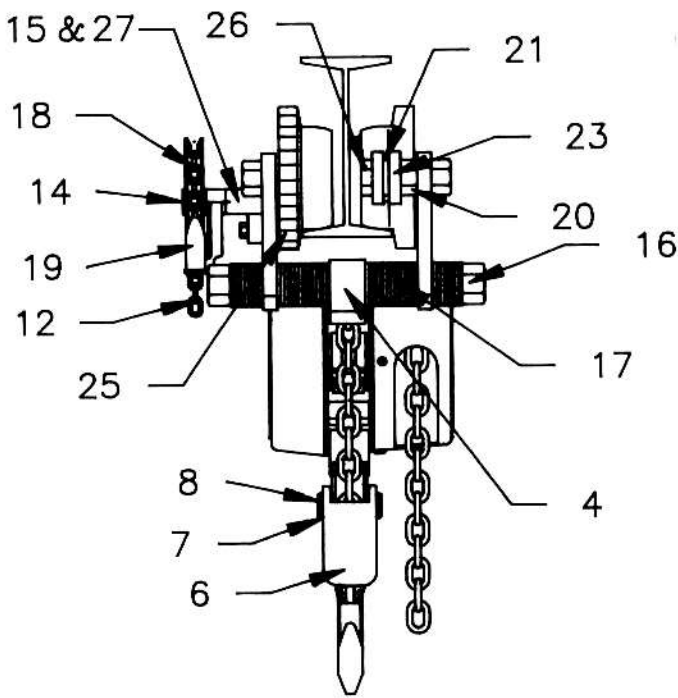

FOR HOIST MECH. ASSEMBLY SEE DRAWING C-35283

ITEM	PART NO.	DESCRIPTION	QUANT.
1	C-35490 C-35491	GEARED SIDE PLATE PLAIN SIDE PLATE	1 1
2	H/L90063	HOOK LATCH	1
3	C-34455	BOTTOM HOOK WITH NUT	1
4	C-35493	LOAD BAR	1
5	132-31-1.5	LIVE END PIN	1
6	C-34460	BOTTOM BLOCK	1
7	1400-75	IDLER PIN SNAP RING	2
8	C-34459	IDLER PIN	1
9	C-34458	IDLER SHEAVE	1
10	B-128	IDLER SHEAVE BEARING	2
11	NTA-1018	THRUST BEARING ASS'Y.	1
12	C-417	TROLLEY DRIVE HAND CHAIN	FT.
13	C-35492	TROLLEY SEPARATOR STUD	2
14	C-35496-A	TROLLEY DRIVE SHAFT ASS'Y. WITH SNAP RING	1

ITEM	PART NO.	DESCRIPTION	QUANT.
15	C-35494	TROLLEY DRIVE SHAFT BR'G. BLOCK WITH LUBE FITTING	1
16	82-.875-2	SEPARATOR STUD NUTS	4
17	6-87-1.46-12	SEPARATOR STUD WASHERS	96
18	C-9120-005	TROLLEY DRIVE HAND WHEEL WITH KEY AND SET SCREW	1
19	C-9121-005	HAND WHEEL GUARD WITH LUBE FITTING	1
20	C-9303-0025	WHEEL SPACERS	20
21	C-23854-R1	WHEEL BEARING SPACERS	4
22	98-62-2	AXLE NUT AND LOCK WASHER	4
23	C-9107-0025	WHEEL BEARING	8
24	C-9109-01	PLAIN TROLLEY WHEEL	2
25	C-9108-01	GEARED TROLLEY WHEEL	2
26	C-9110-015	TROLLEY WHEEL AXLE	4
27	14-31-1	BR'G. BLOCK BOLTS WITH LOCK WASHERS	2

## 1 1/2 & 2 METRIC TON ARMY TYPE HOIST ASSEMBLY PARTS LIST

CHESTER HOIST INC.  
LISBON, OHIO

DR. RLB	TR.	CK.	AP.
SCALE NONE		DATE 2-13-92	
REF. DWG. NO.		R2 DECAL CHANGE	
Dwg. No. C35547R2			

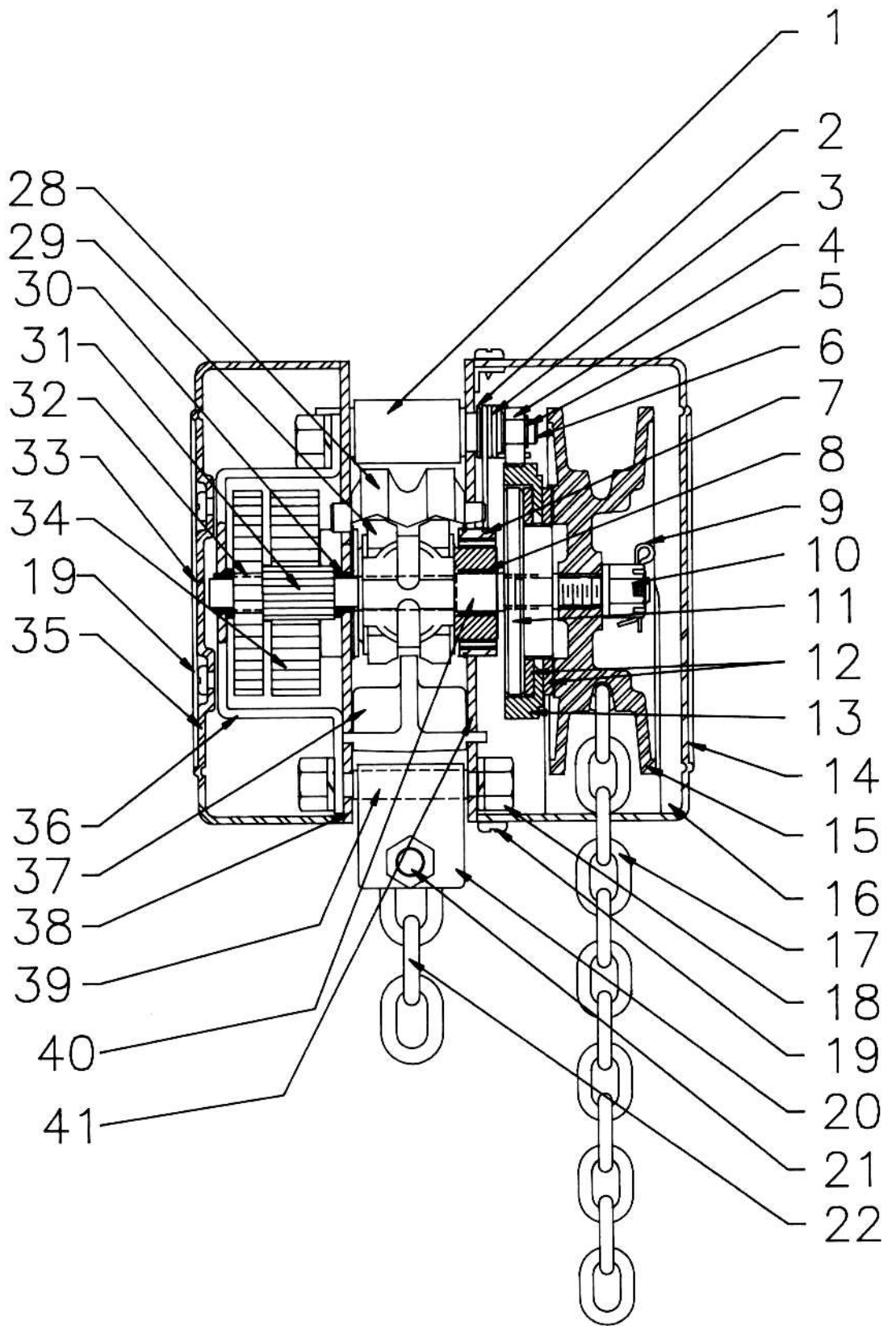

TOL. +/- .0156" ON UNTOL. DIM.

REV.	DESCRIPTION	DATE
01	INITIAL DRAWING	8-3-58
02	REVISIONS	08-20-58

PT. NO.	NO. REQ.
MATL.	WEIGHT
FORM NO. 10 REV. 10-81	

ITEM	PART NO.	DESCRIPTION	QUANT.
1	C-34456	SUSPENSION PIN	1
2	1400-50	PAWL STUD SNAP RING	1
3	C-34107	PAWL SPRING	1
4	C-33017	PAWL	1
5	1400-31	PAWL SNAP RING	1
6	C-33079	PAWL STUD	1
7	6006ZNR	LOAD SHEAVE BEARING WITH SNAP RING	2
8	AA-634-4	SPINDLE BEARING	2
9	135-09-75	SPINDLE COTTER PIN	1
10	78-31-2	SPINDLE NUT WITH WASHER	1
11	C-32995	DISC HUB	1
12	C-33028	BRAKE DISC	2
13	C-32996	RATCHET	1
14	C-34532	HAND WHEEL COVER DECAL	1
15	C-33066	HAND WHEEL	1
16	C-33083	HAND WHEEL COVER	1
17	C-33029	HAND CHAIN	
18	70-31-2	SEPARATOR STUD NUT WITH WASHER	6
19	147-10-37	COVER SCREW	5
20	C-33226	DEAD END CLAMP	1
21	18-25-1	DEAD END BOLT WITH NUT	1
22	C-33030	LOAD CHAIN	
28	C-33015	LOAD CHAIN GUIDE ROLLER	2
29	C-33018	LOAD SHEAVE	1
30	C-33081	PINION BUSHING	4
31	C-34465	PINION ( PART OF ITEM 32 ) NOT SOLD SEP.	-
32	C-32998	SPUR GEAR	2
33	C-34533	GEAR COVER DECAL	1
34	C-32997	SPROCKET GEAR	1
35	C-33082	GEAR COVER	1
36	C-34290	GEAR SUPPORT SPIDER	1
37	C-33016	LOAD CHAIN STRIPPER	1
38	C-33026	GEAR SIDE FRAME	1
39	C-33080	SEPARATOR STUD	3
40	C-33067	SPINDLE	1
41	C-33027	HAND WHEEL SIDE FRAME	1
	C-947-E	BOTTOM BLOCK WARNING TAG	1

CHESTER HOIST INC.  
LISBON, OHIO

CHESTER  
HOIST MECH. ASSEMBLY

DR. RLB	TR.	CHK.	AP.
SCALE NONE		DATE 10-16-81	

REV. 10-81

Dwg. No. C35283R1

## THE FOLLOWING STEPS SHOULD BE NOTED BEFORE USING THE TROLLEY HOIST:

1. Attach the trolley hoist to a supporting structure capable of handling the load to be lifted.
2. The hoist must not be operated until the load block, chain, and hoist body are directly in line with the direction of loading; avoid side pull.
3. Make sure that the load chains are not twisted, kinked or fouled, and that they are properly seated in the pocket wheel before lifting a load. The figure below illustrates how a twist can be introduced into the load chains on a multiple part block.

APPEARANCE OF CHAIN  
THAT HOIST HAD NOT  
BEEN TWISTED

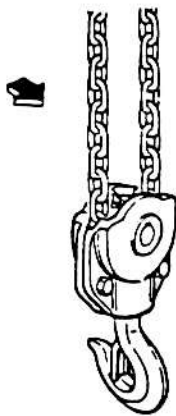

CHECK TO BE SURE  
THAT THE BOTTOM HOOK  
BLOCK HAS NOT BEEN FLIPPED  
THRU CHAIN WITH RESULTANT TWIST

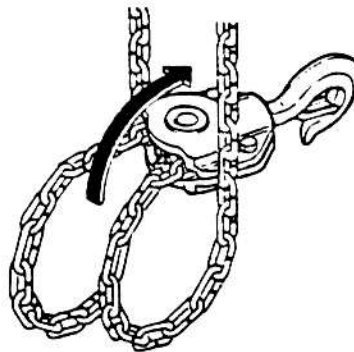

APPEARANCE OF CHAIN  
THAT HAS  
BEEN TWISTED

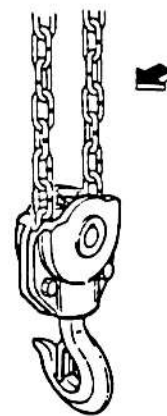

Make sure that multiple chain parts are not twisted and are free to take a load with the load equalized on each supporting strand (part).

4. Use the following as a guideline for properly seating the hooks:
  - a. Make sure that the hook, chain, and hoist body are aligned with the direction of the tension created by the lifting or pulling force.
  - b. When using multiple leg slings to lift loads, refer to the sling load guide charts for allowable leg angles.
  - c. Make sure that the sling or supporting structure fits in the saddle of the hook, and that the safety latch can close completely.
  - d. Do not secure the hook to a supporting structure such that undue strain will be placed on the bill of the hook.

## **DO NOT'S FOR HAND CHAIN OPERATED HOISTS**

The following should be adhered to when operating a hand chain operated chain hoist:

- DO NOT lift more than the rated load.
- DO NOT use a damaged hoist or a hoist that is not working correctly.
- DO NOT use a hoist with twisted, kinked, damaged, or worn chains.
- DO NOT lift a load unless the chain is properly seated in the chain wheels or sprockets.
- DO NOT use the load chain as a sling, or wrap the load chain around the load.
- DO NOT lift a load if any binding prevents equal loading on all load supporting chains.
- DO NOT apply the load to the tip of the hook.
- DO NOT operate the hoist unless the load is centered under the hoist.
- DO NOT operate the hoist with other than manual power.
- DO NOT permit more than one operator to pull on a single hand chain at one time.
- DO NOT allow your attention to be diverted from operating the hoist.
- DO NOT lift a load until all personnel are clear.
- DO NOT operate hoist if you are not physically fit to do so.
- DO NOT operate the hoist beyond the limits of the load chain travel.
- DO NOT use the hoist to lift, support, or transport people.
- DO NOT lift loads over people.
- DO NOT leave a suspended load unattended unless specific precautions have been taken.
- DO NOT allow sharp contact between two hoists or between the hoist and any obstruction.
- DO NOT allow the chain or hook to be used as a ground for welding.
- DO NOT allow the chain or hook to be touched by a live welding electrode.
- DO NOT remove or obscure the warning or safety labels, plates or tags on the hoist.
- DO NOT adjust or repair a hoist unless qualified to perform such maintenance.
- DO NOT attempt to lengthen the load chain or repair a damaged load chain.
- DO NOT place the top of the hook into any link of the chain.
- DO NOT drag the chain or hook on the floor or across other objects.
- DO NOT apply a sudden load to the chain such as pushing a load off a ledge and allowing the chain to "catch" it.
- DO NOT operate a hoist when a "DO NOT OPERATE" sign has been attached until a designated person removes the sign.
- DO NOT lift a load with two hoists unless each hoist has the capacity to handle the entire load.

## **SAFE OPERATING PRACTICES**

### **HAND CHAIN MANUALLY OPERATED CHAIN HOISTS**

#### **DO'S FOR HAND CHAIN OPERATED HOISTS**

The following should be adhered to when operating a hand chain operated chain hoist:

- DO read ANSI B30.16 Safety Standard for Overhead Hoists and the operating instructions provided.
- DO be familiar with hoist operating controls, procedures, and warnings on the hoist.
- DO maintain firm footing or be otherwise secured when operating the hoist.
- DO make sure that the load slings or other approved single attachments are properly sized and seated in the hook saddle.
- DO make sure that the hook latch is closed and not supported by any part of the load.
- DO make sure that the load is free to move and will clear all obstructions.
- DO take up all slack carefully, check the balance of the load, lift a few inches and check the load holding action of the hoist before continuing.
- DO refer to ASME B30.9 for rigging information if rigging is to be used with hoist.
- DO refer to OSHA requirements for safe installation and operation of this hoist.
- DO make sure that all persons stay clear of the suspended load.
- DO avoid swinging of the load or load hook.
- DO protect the load chain from weld splatter or other damaging contaminants.
- DO promptly report any malfunction, unusual performance, or damage, of the unit.
- DO inspect the hoist on a regular basis, replace damaged or worn parts, and keep appropriate records or maintenance. Refer to ANSI B30.16.
- DO use the hoist manufacturer's recommended spare parts when repairing a hoist.
- DO use hook safety latches.
- DO apply lubricant to the load chain as recommended by the hoist manufacturer.
- DO make sure that the top mounting is centered under its means of support before starting a lift.
- DO make sure that the hoist, load block and the hook are directly in line with the direction of loading before making a lift.