

ACCOLIFT®

ELECTRIC CHAIN HOIST with VARIABLE FREQUENCY DRIVE

INSTRUCTION MANUAL

for

Installation / Operation / Maintenance / Parts

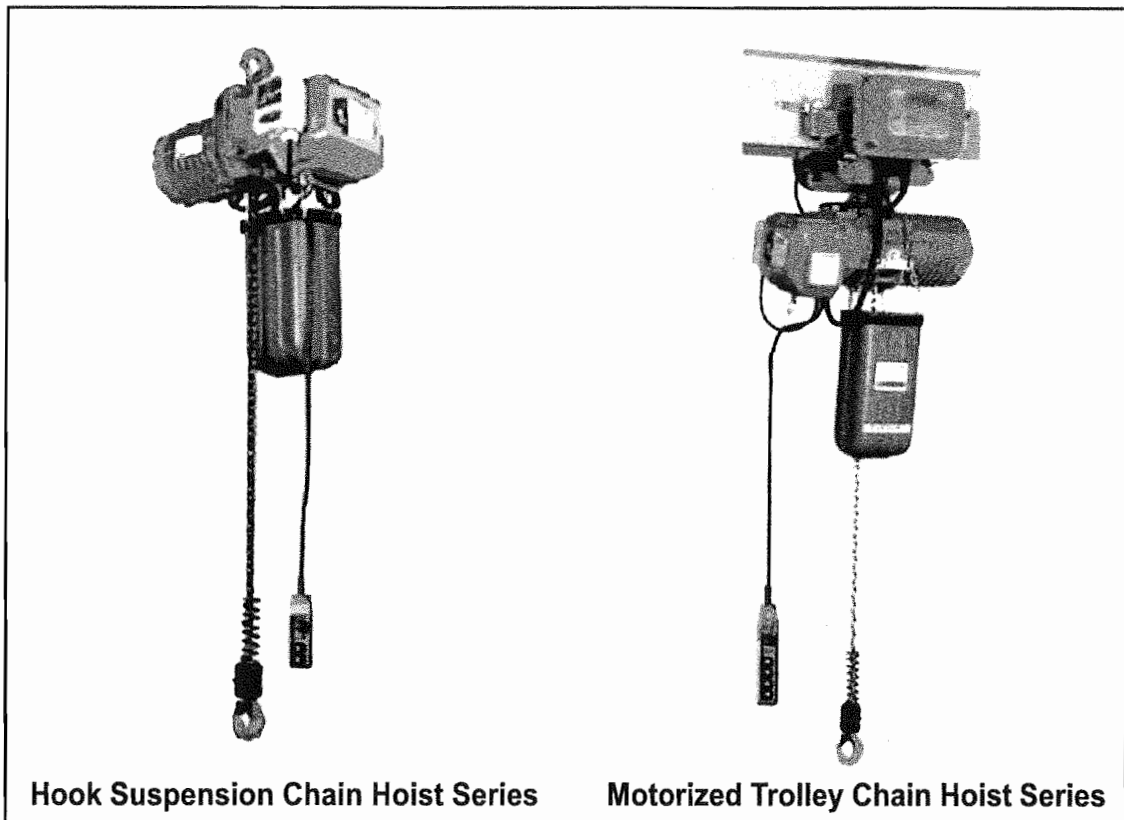

SERIAL NUMBER _____

⚠ WARNING

This equipment should not be installed, operated or maintained by any person who has not read all the contents of these instructions. Failure to read and comply with these instructions or any one of the limitations noted herein can result in serious bodily injury or death, and/or property damage.

There are no other warranties which extend beyond the description on the Order Acknowledgement and as it may apply to the specifications provided in this publication. The IMPLIED WARRANTIES OF MERCHANTABILITY AND FITNESS FOR A PARTICULAR PURPOSE ARE EXCLUDED. Acco shall in no event be liable for any special, direct, indirect, incidental or consequential damages to anyone beyond the cost of replacement of the goods sold hereby.

This manual is to be used in conjunction with manual 71575-03.

TABLE OF CONTENTS

1. General Description of Manual	6
2. Safety Precautions	7
3. Operation Condition & Environment	11
3.1. Operating Hoist	
3.2. Motorized Trolley Traversing	
4. Push Button Control	13
5. Circuit Diagram for Inverter Hoist	14
5.1. Circuit Diagram for Hook Suspension Type Inverter Hoist	
5.2. Circuit Diagram for Motorized Trolley Type Inverter Hoist	
6. Wiring diagram	16
6.1. Wiring Diagram for Hook Suspension Type Inverter Hoist	
6.2. Wiring Diagram for Motorized Trolley Type Inverter Hoist	
7. Trial Operation	18
8. Inverter Parameter Settings	18
9. Inverter Setting and Control	21
9.1. Key Pad Component	
9.2. Display Description	
9.3. LED Description	
9.4. Key Description	
9.5. Viewing and Adjusting Basic (P) and Advanced (A) Parameters	
9.6. Viewing the Display (d) Parameters	
10. Trouble Shooting	26
11. Prevent Leakage Current & Noise Effect	26
11.1. Prevent Leakage Current problem	
11.2. Prevent Noise Effect problem	
12. Maintenance and Inspection	27
13. Parts Illustration for Inverter Hoist	28
14. Parts Illustration for Inverter Trolley	30

NOTICE

TO ORDER PARTS : Provide part number, part description, quantity required, and Product Number or Serial Number of Hoist

SAFETY ALERT SYMBOL 

The Safety Alert Symbol is used in this manual to indicate hazards and to alert the reader to information that should be known, understood, and followed in order to avoid DEATH or SERIOUS INJURY.

Read and understand this manual and manual 71575-03 before using the hoist.

Important issues to remember during operation are provided at the hoist control stations, at various locations of the hoist and in this manual by **DANGER, WARNING or CAUTION** instructions or placards, that alert personnel to potential hazards, proper operation, load limitations, and more.

 DANGER Indicates an imminently hazardous situation which, if not avoided, will result in death or serious injury.

 WARNING Indicates a potentially hazardous situation which, if not avoided, could result in death or serious injury.

 CAUTION Indicates a potentially hazardous situation which, if not avoided, may result in minor or moderate injury. It may also be used to alert against unsafe practices.

 CAUTION

These general instructions deal with the normal installation, operation, and maintenance situations encountered with the equipment described herein. The instructions should not be interpreted to anticipate every possible contingency or to anticipate the final system, crane, or configuration that uses this equipment.

This manual includes instructions and parts information for a variety of hoist types. Therefore, all instructions and parts information may not apply to any one type or size of specific hoist. Disregard those portions of the instructions that do not apply.

Record hoist serial number on the front cover of this manual for identification and future reference to avoid referring to the wrong manual for information or instructions of installation, operation, maintenance, or parts.

Use only Acco authorized replacement parts in the service and maintenance of this hoist.

⚠ WARNING

Equipment described herein is not designed for and should not be used for lifting, supporting, or transporting humans.

Equipment described herein should not be used in conjunction with other equipment unless necessary and/or required safety devices applicable to the system or application are installed by the system designer, system manufacturer, crane manufacturer, installer, or user.

Modifications to upgrade, rerate, or otherwise alter this equipment shall be authorized only by the original equipment manufacturer or qualified professional engineer.

Equipment described herein may be used in the design and manufacture of cranes or monorails. Additional equipment or devices may be required for the crane or monorail to comply with applicable crane design and safety standards.

The crane designer, crane manufacturer, or user is responsible to furnish these additional items for compliance. Refer to ASME B30.17, Safety Standard for Top-Running Single Girder Cranes; ASME B30.2 Safety Standard for Top-Running Double Girder Cranes; and ASME B30.11 Safety Standard for Underhung Cranes and Monorails. If a below-the-hook lifting device or sling is used with a hoist, refer to ASME B30.9, Safety Standard for Slings, or ASME B30.20, Safety Standard for Below-the-hook Lifting Devices.

Hoists and Cranes, used to handle molten material may require additional equipment or devices. Refer to ANSI Z241.2, Safety Requirements for Melting and Pouring of Metals in the Metalcasting industry.

Electrical equipment described herein is designed and built in compliance with Acco Material Handling Solutions interpretation of ANSI/NFPA 70, National Electrical Code. The system designer, system manufacturer, crane designer, crane manufacturer, installer, or user is responsible to assure that the installation and associated wiring of these electrical components is in compliance with ANSI/NFPA 70, and all applicable Federal, State, and Local Codes.

Failure to read and comply with any one of the limitations noted herein can result in serious bodily injury or death, and/or property damage.

⚠ DANGER

HAZARDOUS VOLTAGES ARE PRESENT IN THE CONTROL BOX, OTHER ELECTRICAL COMPONENTS, AND CONNECTIONS BETWEEN THESE COMPONENTS

Before performing ANY mechanical or electrical maintenance on the equipment, de-energize (disconnect) the main switch supplying power to the equipment; and lock and tag the main switch in the de-energized position. Refer to ANSI Z244.1, Personnel Protection - Lockout/Tagout of Energy Sources

⚠ DANGER

Do not operate the equipment without control enclosure cover or covers in place. Only trained and competent personnel should inspect and repair this equipment

NOTICE

It is the responsibility of the owner/user to install, inspect, test, maintain, and operate a hoist in accordance with ASME B30.16, Safety Standard for Overhead Hoists, OSHA Regulations, and ANSI/NFPA 70, National Electric Code. If the hoist is installed ad part of a total lifting system, such as an overhead crane or monorail, it is also the responsibility of the owner/user to comply with the applicable ASME B30 volume that addresses that type of equipment.

It is the responsibility of the owner/user to have all personnel that will install, inspect, test, maintain, and operate a hoist read the contents of this manual, manual 71575-03, manual D2-3499-3 and applicable portions of ASME B30.16, Safety Standard for Overhead Hoists, OSHA Regulations, and ANSI/NFPA 70, National Electrical Code. If the hoist is installed as part of a total lifting system, such as an overhead crane, the applicable ASME B30 volum that addresses that type of equipment must also be read by all personnel.

Any ANSI Standards referenced in this manual may be obtained from the American National Standards Institute, 1430 Broadway, New York, New York 10018.

The manuals contain information for safe operation of an overhead hoist. Taking precedence over any specific rule, however, is the most important rule of all - "USE COMMON SENSE." Operation of an overhead hoist involves more than operating the controls. The operator must consider and anticipate the motions and actions that will occur as a result of operating the controls.

If the hoist owner/user requires additional information, or if any information in the manual is not clear, contact Acco Material Handling Solutions, York, Pennsylvania or the distributor of the hoist. Do not install, inspect, test, maintain, or operate this hoist unless this information is fully understood.

When contacting Acco Material Handling Solutions or the distributor of the hoist, always make reference to the serial number of the hoist.

A regular schedule of inspection of the hoist in accordance with the requirements of ASME B30.16 should be established and records maintained.

⚠ WARNING

Before installing, removing, inspecting, or performing any maintenance on a hoist, the main switch shall be de-energized. Lock and tag the main switch in the de-energized position in accordance with ANSI Z244.1. Follow other maintenance procedures outlined in this manual, manual 71575-03, manual D2-3499-3 and applicable ASME B30 volumes.

Additional WARNINGS are listed in various portions of this manual, manual 71575-03 and manual D2-3499-3. Personnel shall read and follow these WARNINGS. Failure to read and comply with these WARNINGS as well as other instructions or any limitations noted in this manual, manual 71575-03, manual D2-3499-3 and applicable ASME B30 volumes could result in serious bodily injury or death, and/or property damage.

⚠ WARNING

ACCOLIFT[®] electric chain hoists are designed for indoor use. For outdoor use, the hoist shall be located under roof to assure rainproof operation. The operator SHALL

- NOT expose the hoist to rain or condensation.
- NOT store the hoist in a humid place.
- COVER the hoist or MOVE it back under roof after use, when it is used outdoors.
- HANG the hoist on a suitable beam or crane or from the ceiling.

1. General description of manual

The product is supplied together with the manuals that are important to keep readily accessible:

- During installation or set-up
- For training operators & the maintenance of the equipment
- The "Safety Precautions" & Operation instructions

This inverter hoist manual 71575-03-VFD is to be used in conjunction with the standard hoist instruction manual 71575-03.

For inverter operation, refer to the inverter instruction manual D2-3499-3 (MD60 AC Drive User Manual).

This inverter hoist manual is designed to allow precise operation by adjustment of the rate of lifting and lowering speed of the hoist and traveling speed of the trolley.

2. Safety precautions

2.1 Warning and Caution

The Safety Alert Symbols are used to indicate hazards and to alert the reader to information that should be known, and understood, and followed in order to avoid SERIOUS BODILY INJURY or DEATH and/or PROPERTY DAMAGE.

▲ WARNING

WARNING symbol indicates a potentially hazardous situation, which, if not avoided, could result in death or serious injury. To avoid such a potentially hazardous situation, THE OPERATOR SHALL

- NOT operate a damaged, malfunctioning or unusually performing hoist.
- NOT operate the hoist until you have thoroughly read and understand the manuals.
- NOT operate a hoist which has been modified without the manufacturer's approval.
- NOT lift more than rated load for the hoist.
- NOT use hoist with twisted, kinked, damaged, or worn load chain.
- NOT use the hoist to lift, support, or transport people, nor lift or transport loads over or near people.
- NOT operate unless load is centered under hoist.
- NOT attempt to lengthen the load chain or repair damaged load chain.
- Protect the hoist's load chain from weld splatter or other damaging contaminants.
- NOT operate hoist when it is difficult to form a straight line from hook to hook in the direction of loading.
- NOT use load chain as a sling, or wrap chain around the load.
- NOT apply the load to the tip of the hook or to the hook latch.
- NOT apply load unless load chain is properly seated in the chain sprocket(s).
- NOT apply load if bearing prevents equal loading on all load supporting chains.
- NOT operate beyond the limits of the load chain travel.
- NOT leave load supported by the hoist unattended unless specific precautions have been taken.
- NOT allow the load chain or hook to be used as an electrical or welding ground.
- NOT allow the load chain or hook to be touched by a live welding electrode.
- NOT remove or obscure the warnings on the hoist.
- NOT operate a hoist on which the safety placards or decals are missing or illegible.
- NOT operate a hoist unless it has been securely attached to a suitable support.
- NOT operate a hoist unless load slings or other approved single attachments are properly sized and seated in the hook saddle.
- Take up slack carefully-make sure load is balanced and load holding action is secure before continuing.
- Shut down a hoist that malfunctions or performs unusually and report such malfunction.
- Make sure hoist limit switches function properly.
- Warn personnel of an approaching load

⚠ CAUTION

Read and understand this manual, manual 71575-03 and manual D2-3499-3 before using the hoist. Taking precedence over any specific rule, however, is the most important rule of all: "USE COMMON SENSE"

It is the responsibility of the owner / user to

1. Install, inspect, test, maintain, and operate the hoist in accordance with the instruction manuals furnished by the manufacturer of the hoist...
2. Train and designate hoist operators, and
3. Train and designate hoist inspectors / maintenance personnel.

2.2. Checking of electricity

⚠ WARNING

Before installing, removing, inspection, or performing any maintenance on the hoist, the main switch shall be de-energized and locked out and tagged out in accordance with ANSI Z244.1 Do not use this equipment in hazardous locations.

- the electric chain hoist shall be connected to an earth ground.
- Lock-out and tag-out the main disconnect switch, in the de-energized position, before performing any service on the hoist.
- The customer must supply the power supply cable, the fuses and the main disconnect switch.
- Check that the supply voltage is the same as the nameplate voltage on the hoist.
- Check that the voltage does not vary by more than $\pm 10\%$ from the nominal value.
- Do not use conductors smaller than those listed in the manual, to supply power to the hoist.
- Never bypass limit switches, remove limit switch stops, or otherwise defeat limit switch devices.

2.3. Initial start-up

Once the checks in this manual and manual 71575-03 have been completed, proceed as follows (be ready to press the emergency stop button at all time).

1. Start operating the hoist without a load.
2. Check, when not under load, that the movement of the hook corresponds to the direction of the arrows on the pushbutton station.
3. Check the operation of the hoist limit switch: operate the hoist, without a load, until it reaches the upper and lower hook positions and let the limiter slip briefly

4. Check the operation of the brake: lift up a nominal load and then lower it.
5. Perform a load test with +10% of the nominal load and static tests with +25% of the nominal load on your installation equipped with our hoist.
6. The hoist which you have just purchased should only be used with a maximum load equal to the hoist's rated load. The length of its useful service life depends on the demands placed upon it, the average operating time, the number of start-stops and proper maintenance.

2.4. Precautions during operation

⚠ CAUTION

Indicates a potentially hazardous situation, which, if not avoided, MAY result in minor or moderate injury. To avoid such a potentially hazardous situation, THE OPERATOR SHALL

1. Perform a daily inspection according to the instruction manuals.
2. Inspect the load chain for any type of deformation or damage and check the load chain lubrication.
3. Visually inspect hooks and hook latches for any type of deformation of throat opening, wear on saddle or load bearing point, and twisting.
4. Report missing or illegible warning labels to the supervisor.
5. NOT operate the hoist if any damage or malfunctions exist.
6. Know hand signals used for hoist operations as per instruction manuals.
7. Always notify others when a load transport is about to begin.
8. Always make sure that the supporting structures are strong enough to support the weight of the load and hoist.
9. Maintain firm footing or be otherwise secured when operating the hoist.
10. Check brake function by tensioning the hoist prior to each lift operation.
11. Use hook latches. Latches are to retain slings, chains, etc. under slack conditions only.
12. Place slings balanced on the bottom hook. Avoid "Improper" slinging cases shown below.

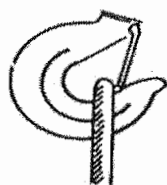

Improper 1

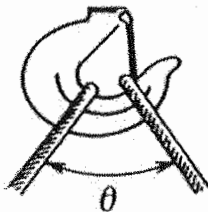

Improper 2

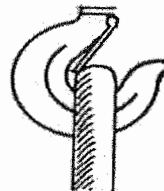

Improper 3

13. Make sure the hook latches are closed and not supporting any parts of the load.
14. Make sure the load is free to move and will clear all obstructions.
15. Avoid swinging the load or hook.
16. Make sure hook travel is in the same direction as shown on the controls.
17. Inspect the hoist regularly, replace damaged or worn parts, and keep appropriate records of maintenance

ELECTRIC CHAIN HOIST

18. Use only manufacturer's recommended parts when repairing the unit.
19. Lubricate load chain per hoist manufacturer's recommendations.
20. NOT use the hoist's overload limiting clutch to measure load.
21. NOT use limit switches as routine operating stops. They are emergency devices only.
22. NOT allow your attention to be diverted from operating the hoist.
23. NOT allow the hoist to be subjected to sharp contact with other hoists, structures, or objects through misuse.
24. NOT adjust or repair the hoist unless qualified to perform such adjustments or repairs.
25. The hoist should be maintained regularly, following the instructions in the manuals.
26. Keep the moving components clean and oiled as indicated in the manuals.
27. Make sure that the limit switch stops are in place, and that all limit switches are functioning properly...
28. Before operation, check that the load is correctly fastened and installed on the hook.
29. When moving the load, make sure that it is sufficiently raised and distant from the surrounding machines and other objects so as to avoid all obstacles during operation.
30. Make sure that the hoist is vertical to the load before moving it.
31. If manually moving the hoist, push the load.
32. Avoid rocking the load or the hook when using the traveling trolley or crane, by limiting the starting and braking jerks.
33. Use the material under normal working conditions with ambient temperature, atmosphere.
34. Use only for indoor operation of hoist. For outdoor operation, provide adequate protection to ensure a rainproof environment.
35. NOT operate the hoist if any damage or malfunctions exist; and SHALL report any damage or malfunctions to the supervisor.
36. NOT operate the hoist if tagged-out.
37. NOT lift, lower, or transport personnel by means of the hoist, hoist trolley, hoist hook, or load.

NOTICE

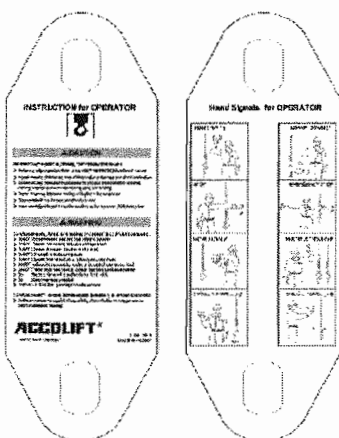

Always read and follow the INSTRUCTION for OPERATOR, which contains the main CAUTION and WARNING instructions. It shall be assembled onto the Push Button Switch Control regardless of working conditions. For safer hoisting operation, please refer to the Hand Signals for OPERATOR on the backside.

2.5. Precautions during maintenance and servicing

Electrical connection:

⚠ WARNING

(customer responsible scope for installation)

Before removing the control box cover, check that the hoist power supply is disconnected and locked and tagged per ANSI Z244.1

- The customer must supply the power supply cable, the fuses and the main disconnect switch (refer to the wiring diagram).
- Check that the power supply voltage is correct for the hoist.
- Check that the voltage does not vary by more than $\pm 10\%$ from the nominal value.
- Make sure that the main hoist power disconnect switch is de-energized and after 1 minute, make sure that the inverter's RUN light has gone off.
- Do not use conductors smaller than those listed in the manual to supply power to the hoist.
- Never bypass limit switches, remove limit switch stops, or otherwise defeat limit switches.

3. Operating Conditions and Environment

Supply voltage		3Phase, 208~230V/460V, 60Hz
Environment	Temperature Range	-10°C~40°C
	Humidity	80%RH or less
	Location	Non Corrosive, Combustible gas, oil misty or dusty atmosphere
Enclosure Rating		IP55
Intermittent Duty Rating (%ED)	Lifting	High Speed (60Hz) - 40% ED
	Traveling	Low Speed (10Hz) - 20% ED

3.1. Operating Hoist (Dual Speed)

- Low speed at the first step, high speed at the second step.
- Acceleration time of 5.0 seconds.

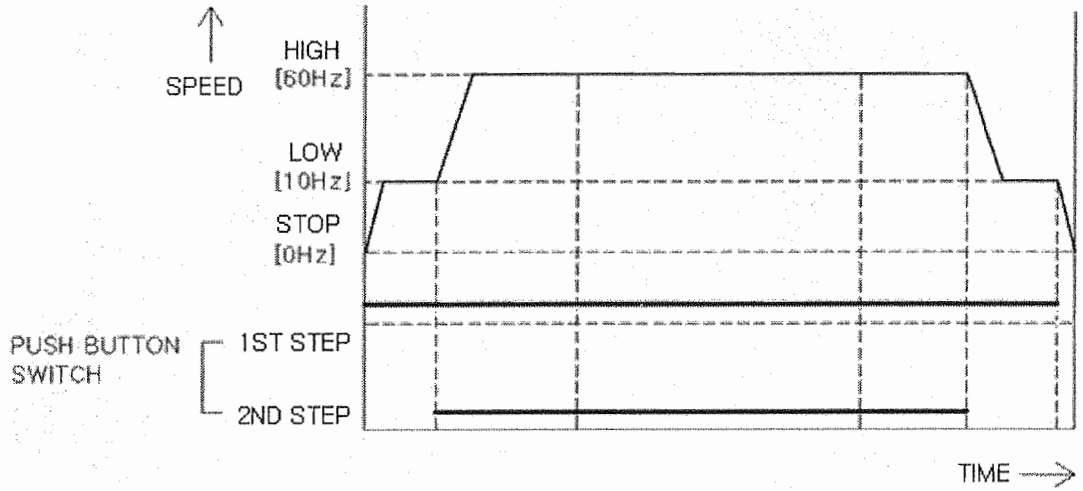

3.2. Motorized Trolley Traversing (Dual Speed)

- First step for low speed traversing and second step for high speed traversing.
- Acceleration time of 5.0 seconds and deceleration time of 3.0 seconds.

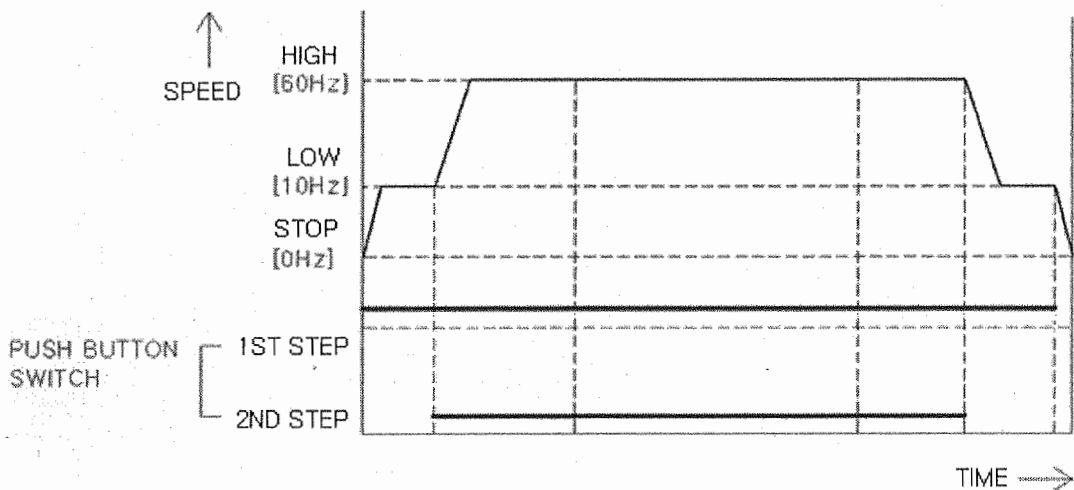

4. Push Button Control for Inverter Hoist

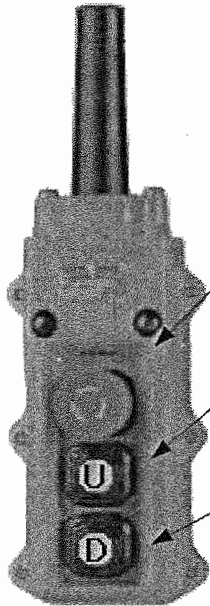

<ul style="list-style-type: none"> ■ Reset Button (Emergency Stop Button) ■ To restore the tripped inverter, press this button
<ul style="list-style-type: none"> ■ Hoist Up <ul style="list-style-type: none"> - First Step : Slow Speed - Second Step : Fast Speed
<ul style="list-style-type: none"> ■ Hoist Down <ul style="list-style-type: none"> - First Step : Slow Speed - Second Step : Fast Speed

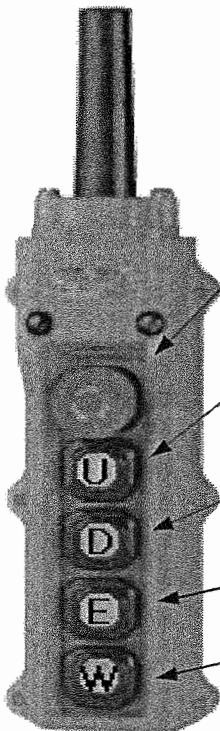

<ul style="list-style-type: none"> ■ Reset Button (Emergency Stop Button) ■ To restore the tripped inverter, press this button
<ul style="list-style-type: none"> ■ Hoist Up <ul style="list-style-type: none"> - First Step : Slow Speed - Second Step : Fast Speed
<ul style="list-style-type: none"> ■ Hoist Down <ul style="list-style-type: none"> - First Step : Slow Speed - Second Step : Fast Speed
<ul style="list-style-type: none"> ■ Trolley Forward / Reverse <ul style="list-style-type: none"> - First Step : Slow Speed - Second Step : Fast Speed

5. CIRCUIT DIAGRAM FOR INVERTER HOIST

5.1. Circuit Diagram for Hook Suspension Type Inverter Hoist

2 STEP SPEED INVERTER CIRCUIT DIAGRAM

MODEL: Hook Suspension Type (1ton, 2ton, 3ton, 5ton)

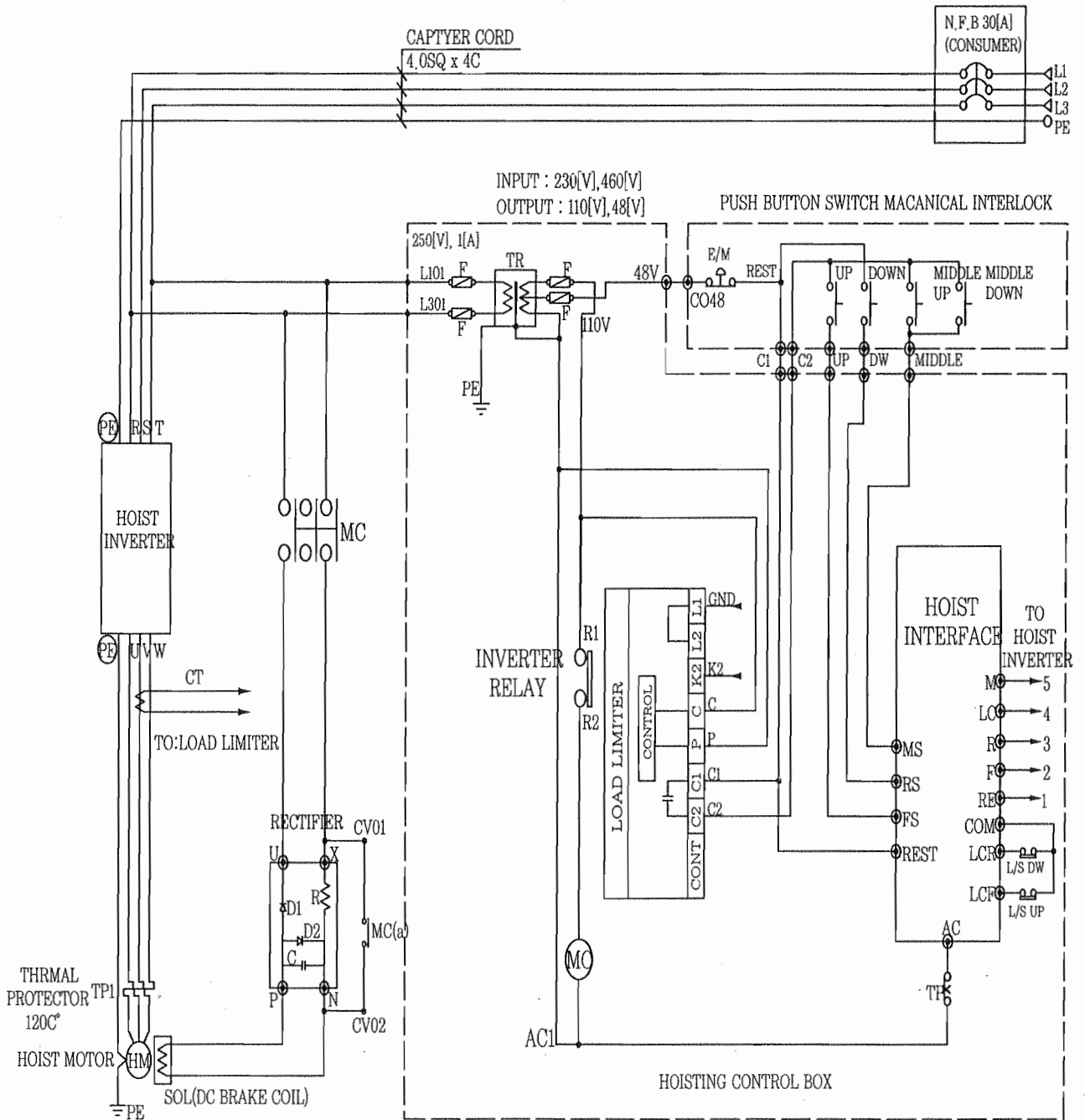

NOTE

1. POWER CONNECTION WIRE : 2.5SQ(BLACK)
2. CONTROL CONNECTION WIRE : 1.5SQ(RED)

5.2. Circuit Diagram for Motorized Trolley Type Inverter Hoist

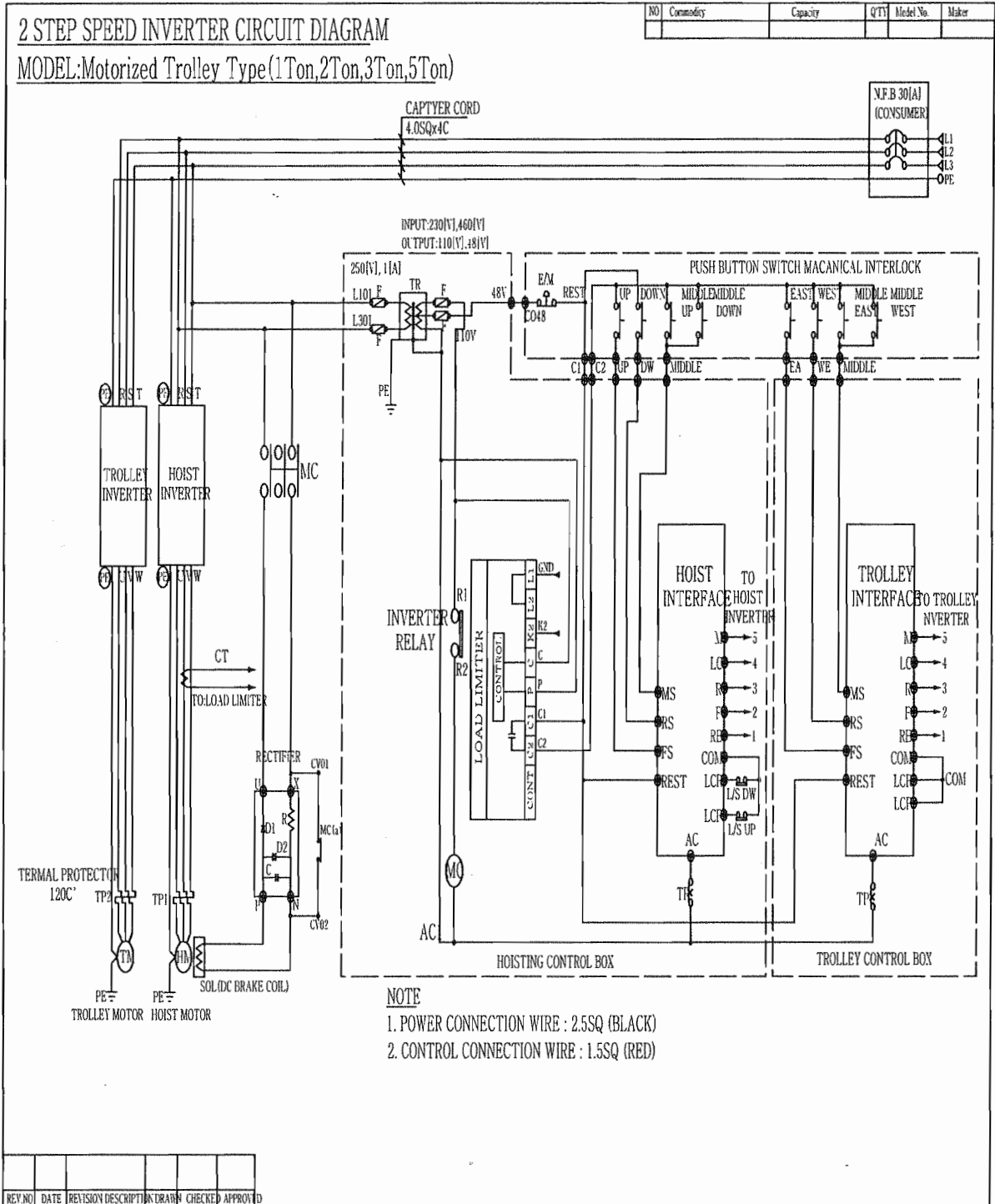

6. WIRING DIAGRAM FOR INVERTER HOIST

6.1 Wiring Diagram for Hook Suspension Type Inverter Hoist

2 STEP SPEED INVERTER WIRE DIAGRAM

MODEL : HOOK SUSPENSION TYPE (EDSA-1S)

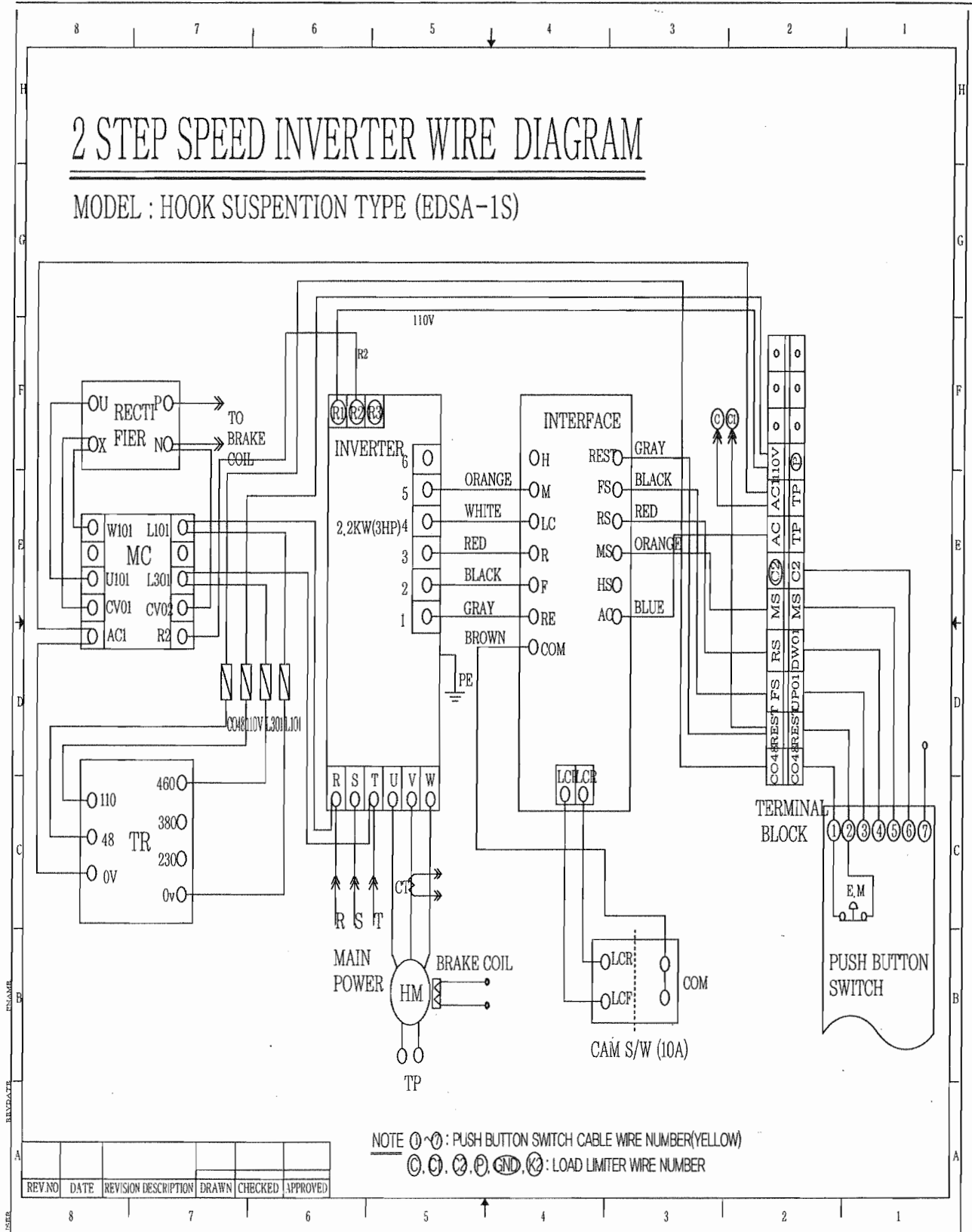

NOTE ①~⑦ : PUSH BUTTON SWITCH CABLE WIRE NUMBER (YELLOW)
 ①, ②, ③, ④, ⑤, ⑥, ⑦ : LOAD LIMITER WIRE NUMBER

REV. NO.	DATE	REVISION DESCRIPTION	DRAWN	CHECKED	APPROVED

2 STEP SPEED INVERTER WIRE DIAGRAM

MODEL : HOOK SUSPENSION TYPE (EDSA-2S,3W,5W)

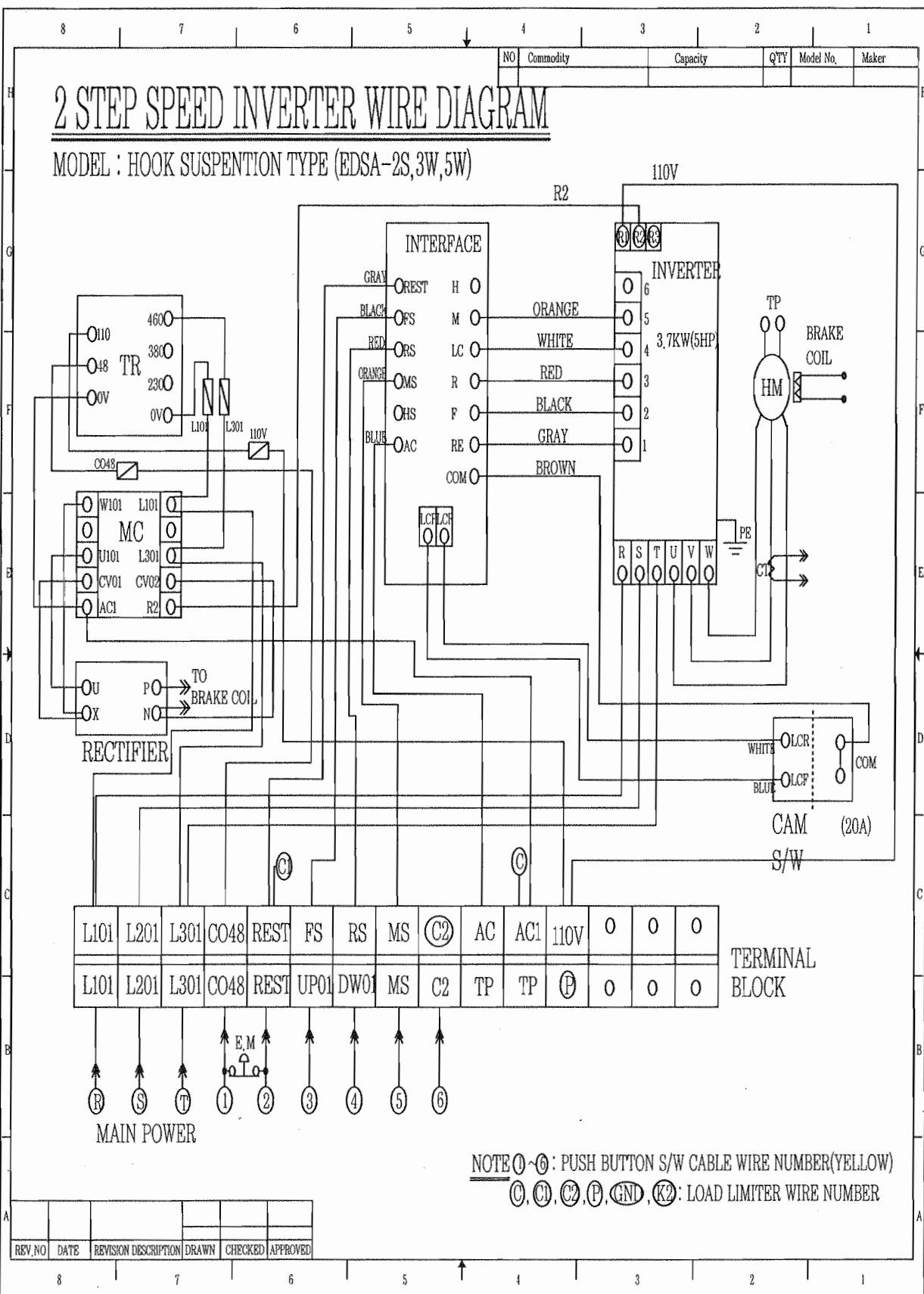

L101	L201	L301	CO48	REST	FS	RS	MS	(C2)	AC	AC1	110V	0	0	0
L101	L201	L301	CO48	REST	UP01	DW01	MS	C2	TP	TP	(P)	0	0	0

TERMINAL BLOCK

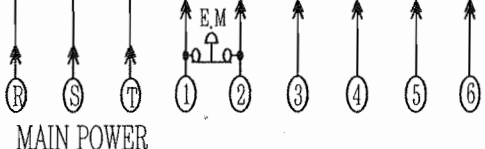

NOTE ①~⑥ : PUSH BUTTON S/W CABLE WIRE NUMBER(YELLOW)
 ①, ②, ③, ④, ⑤, ⑥ : LOAD LIMITER WIRE NUMBER

REV. NO	DATE	REVISION DESCRIPTION	DRAWN	CHECKED	APPROVED

6.2. Wiring Diagram for Motorized Trolley Type Inverter Hoist

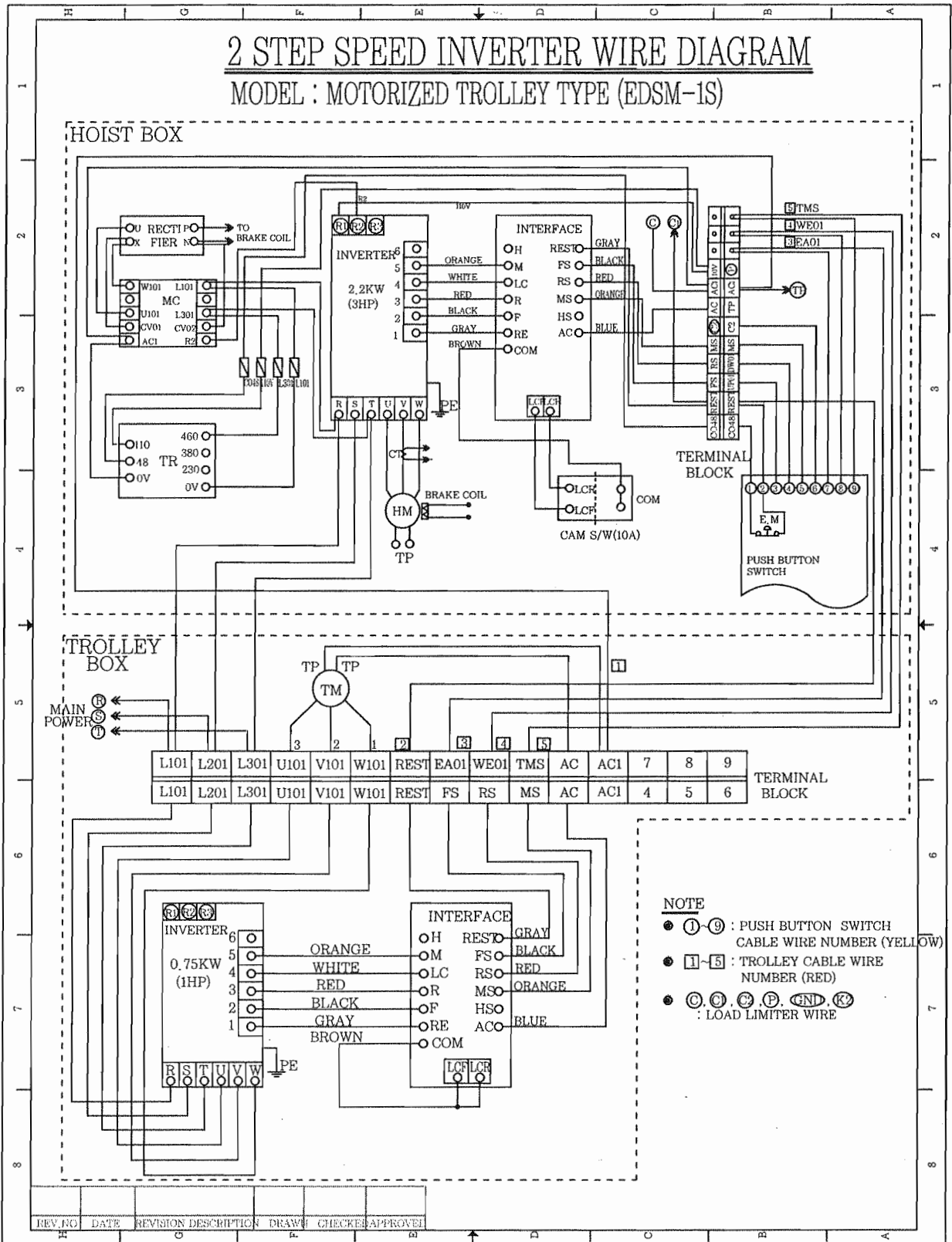

2 STEP SPEED INVERTER WIRE DIAGRAM

MODEL : MOTORIZED TROLLEY TYPE (EDSM-2S,3W,5W)

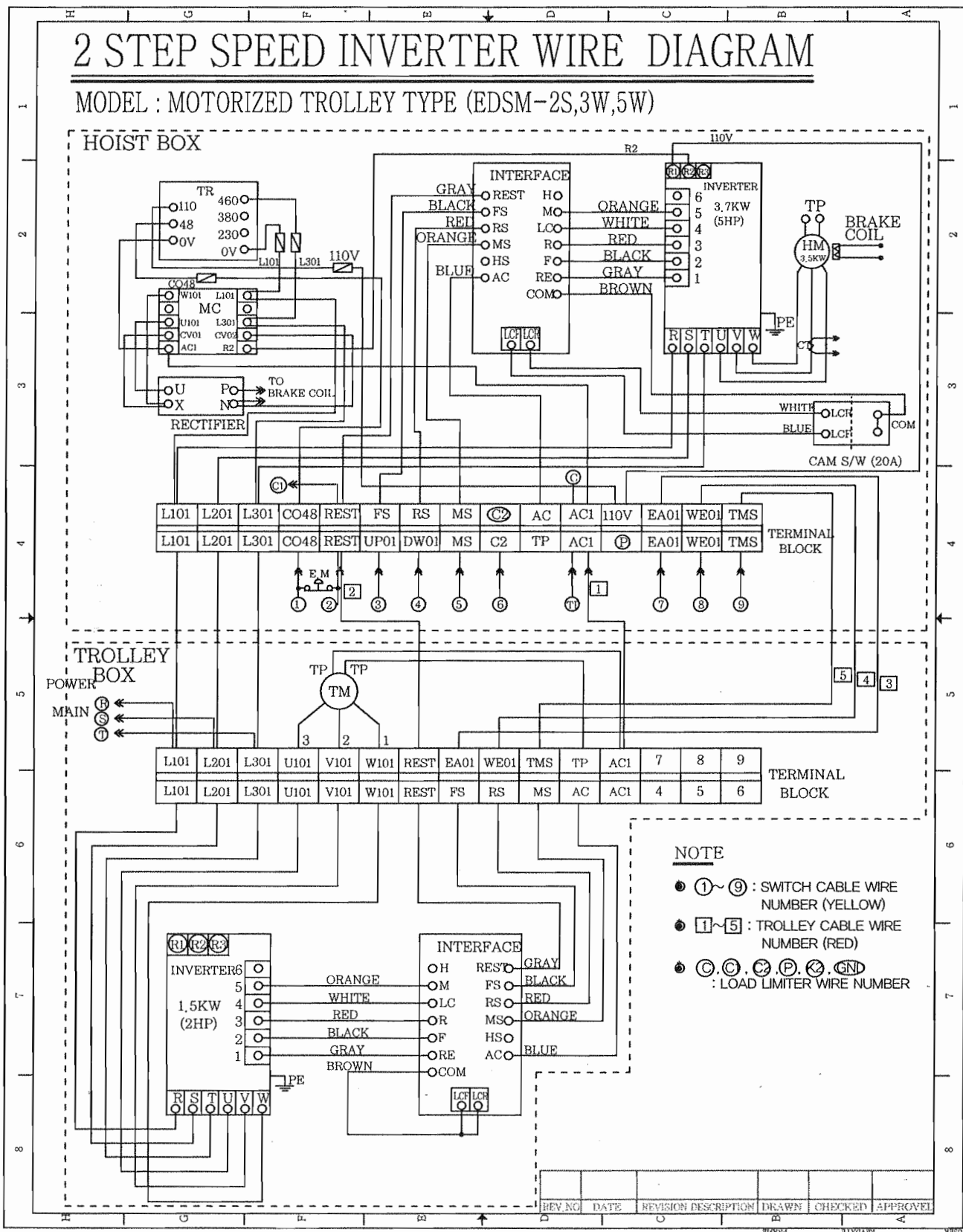

7. TRIAL OPERATION

⚠ DANGER

DISCONNECT POWER AND LOCKOUT DISCONNECTING MEANS BEFORE PERFORMING SERVICE TO ELECTRICAL PARTS OF THIS EQUIPMENT.

The inverter drive contains high voltage capacitors that take time to discharge after removal of power supply. Wait for 3 minutes for capacitors to discharge to safe voltage levels before proceeding with any check ups of electrical parts of this equipment after shutting down the power.

Failure to read and comply with any of the limitations noted herein will result in serious bodily injury or death, and/or property damage.

⚠ WARNING

- Check that all wiring has been completed before performing trial operation.
- Don't change wiring of push button switch.
- To change the acceleration or deceleration time, refer to inverter manual.
- Only authorized personnel should perform the operation. Operating personnel should read and understand all the contents of this manual together with ACCO standard manual 71575-03.
- Failure to comply with any of the limitations noted herein can result in serious bodily injury or death and/or property damage.

8. INVERTER PARAMETER SETTINGS

ACCOLIFT 2-STEP SPEED INVERTER SETTINGS

CAPACITY	HOIST HZ SETTING	HOIST ACCEL SETTING	HOIST DECEL SETTING
	SET A070 / A071 - LIFTING(up/down)	SET P039	SET P040
1TON	16 Hz (FPM 7) - 47 Hz (FPM 21)	5.0 SEC	0.2 SEC
2TON	16 Hz (FPM 7) - 48 Hz (FPM 21)	5.0 SEC	0.2 SEC
3TON	18 Hz (FPM 5) - 54 Hz (FPM 15)	5.0 SEC	0.2 SEC
5TON	18 Hz (FPM 4) - 63 Hz (FPM 11)	5.0 SEC	0.2 SEC

CAPACITY	TROLLEY HZ SETTING	TROLLEY ACCEL SETTING	TROLLEY DECEL SETTING
	SET A70 / A71 TRAVERSING(left/right)	SET P039	SET P040
1TON	21 Hz (FPM 17) - 62 Hz (FPM 50)	5.0 SEC	3.0 SEC
2TON	21 Hz (FPM 17) - 62 Hz (FPM 50)	5.0 SEC	3.0 SEC
3TON	23 Hz (FPM 17) - 68 Hz (FPM 50)	5.0 SEC	3.0 SEC
5TON	23 Hz (FPM 17) - 68 Hz (FPM 50)	5.0 SEC	3.0 SEC

▲ WARNING

- Do not change any parameter value not indicated in this manual
- Do not set a value that exceeds a parameter range given in inverter manual D2-3499-3 (MD60 AC Drive User Manual).
- Make sure to perform trial operation after changing a parameter value. If there is anything wrong, stop the operation immediately and check the values and correct them.

NOTICE

- To change the parameter value, refer to the inverter manual D2-3499-3 (MD60 AC Drive User Manual). Before making any changes in the inverter, clear understanding of the inverter manual is required.

9. INVERTER SETTING AND CONTROL

Factory-default parameter values allow the drive to be controlled from the integral keypad. No programming is required to start, stop, change direction, or control speed directly from the integral keypad.

9.1. Keypad Components

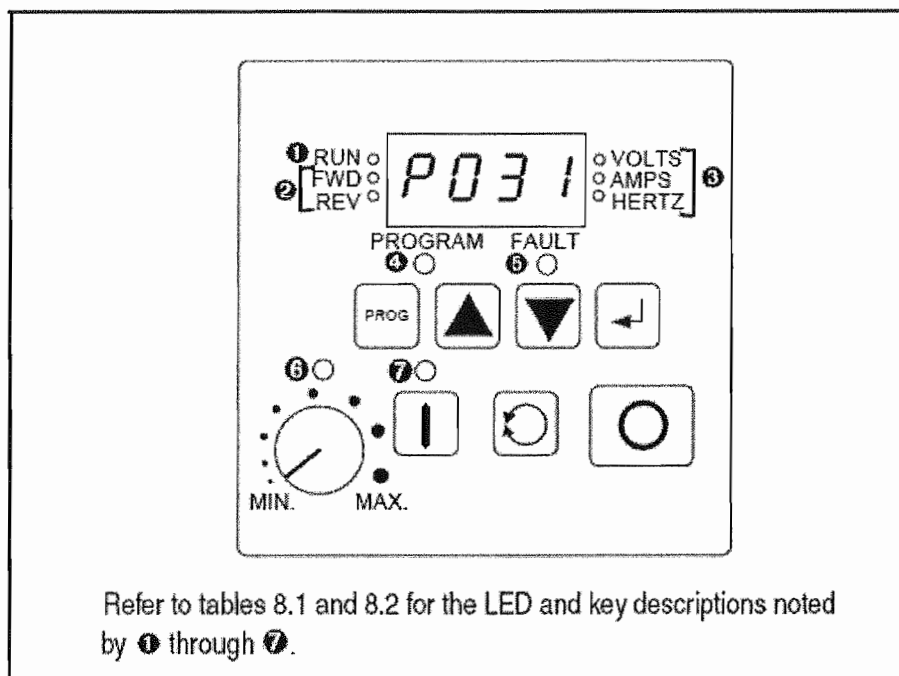

Figure 8.1 – Integral Keypad

9.2. Display Description

The alpha-numeric display indicates the following :

- Parameter number
- Parameter value
- Fault code

9.3. LED Description

Refer to figure 8.1 for the location of the LEDs described in table 8.1.







Table 8.1 – LED Descriptions

No.	LED	LED State	Description
①	RUN	Steady Red	Indicates the drive is running.
②	FWD REV	Flashing Red	Drive has been commanded to change direction. Indicates actual motor direction while decelerating to zero.
		Steady Red	Indicates the commanded motor direction.
③	VOLTS AMPS HERTZ	Steady Red	Indicates the units of the parameter value being displayed.
④	PROGRAM	Steady Red	Indicates the drive is in program mode and the parameter value can be changed.
⑤	FAULT	Flashing Red	Indicates drive is faulted.
⑥	Pot Status	Steady Green	Indicates potentiometer on integral keypad is active.
⑦	Start Key Status	Steady Green	Indicates Start key on integral keypad is active. The Reverse key is also active unless disabled by A095 (Reverse Disable).

9.4. Key Descriptions

Refer to figure 8.1 for the location of the keys described in table 8.2.

Table 8.2 – Key Descriptions











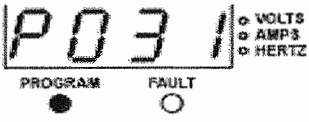

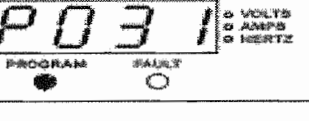

Key	Name	Description
	Program	<ul style="list-style-type: none"> • Enter/exit program mode. • Scroll through parameter groups. • Back up one step in programming menu. • Cancel a change to a parameter value.
	Up Arrow Down Arrow	<ul style="list-style-type: none"> • Scroll through P and A parameters. • Increase/decrease the value of a flashing digit. • In Display Mode, increases/ decreases internal frequency parameter if that parameter is currently controlling the drive commanded speed.
	Enter	<ul style="list-style-type: none"> • Display value of P or A parameter. • Save a change to a parameter value. • Scroll through display (d) parameters.
	Potentiometer	Control drive speed. Default is active. Controlled by parameter P038.
	Start	Start the drive. Default is active. Controlled by parameter P036.
	Reverse	Reverse direction of the motor. Default is active. Controlled by parameters P036 and A095.
	Stop	<ul style="list-style-type: none"> • Stop the drive (if drive is running). • Clear fault (if drive is stopped). Controlled by parameter P037.

9.5. Viewing and Adjusting Basic (P) and Advanced (A) Parameters

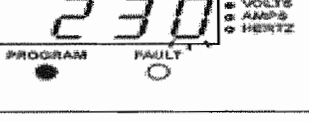
Parameters are organized into three parameter groups:

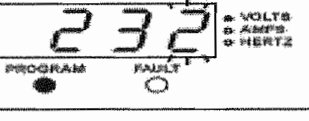
- The Basic Parameter Group (Pnnn) contains the most commonly used parameters to simplify the start-up process.
- The Advanced Parameter Group (Annn) contains parameters used for more advanced applications.
- The Displayed Parameter Group (dnnn) contains parameters that indicate actual drive conditions.

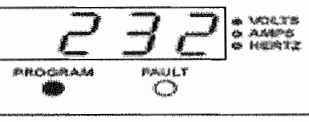
Table 8.3 – Viewing and Adjusting Basic (P) and Advanced (A) Parameters

Procedure	Sample Display
Step 1. Press  until the desired parameter group is displayed. The PROGRAM LED will turn on to indicate the drive is in program mode.	
Step 2. Press   to scroll through the parameters in the selected parameter group.	
Step 3. Press  to view the value of the displayed parameter.	
Step 4. Press  or   . The adjustable value will flash on the display.	
Step 5. Use   to adjust the value.	
Step 6. Press  to accept the value. The value stops flashing.	
Step 7. Press  to return to the parameter number.	

To adjust additional parameters, repeat steps 2 through 7.





To exit a parameter without saving the value, press  instead of

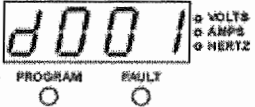

9.6. Viewing the Display (d) Parameters

Use the procedure in table 8.4 to view Display parameters.

Table 8.4 – Viewing the Display (d) Parameters

Procedure	Sample Display
<p>Step 1. Press  to scroll through the parameter menus until the Display Group parameters are displayed. The PROGRAM LED will be off to indicate the drive is in display mode.</p>	
<p>Step 2. Press  to scroll through the Display Group parameters until the desired Display parameter is displayed.</p>	
<p>Step 3. The parameter value will be displayed 3 seconds after  is released.</p>	

To view additional Display parameters, press  to return to the Display Group parameter list and scroll through the parameter list as described in step 2.

Note that the last user-selected Display parameter is saved when power is removed and is displayed by default when power is re-applied.

* For more detailed inverter operation, refer to the inverter manual
 -> D2-3499-3 (MD60 AC Drive User Manual)

10. Trouble Shooting

⚠ DANGER

DISCONNECT POWER AND LOCKOUT DISCONNECTING MEANS BEFORE PERFORMING SERVICE TO ELECTRICAL PARTS OF THIS EQUIPMENT.

Only a qualified electrician should perform service to electrical parts of this equipment.

- For trouble shooting of the inverter unit, refer to the inverter manual and respond accordingly.

Example of typical problem

- 1) Motor doesn't work.
- 2) Motor rotates backward.
- 3) Trolley travels at a speed excessively different from the rated speed.
- 4) Acceleration or deceleration is not smooth.
- 5) Excessive current runs to the motor

11. Prevent Leakage Current & Noise Effect

11.1. Prevent Leakage Current problem

⚠ WARNING

- Leakage current generated through the inverter's input/output line or motor electrostatic capacitance may badly affect other equipment.
- Since the amount of leakage current depends on carrier frequency (number of switching pulses per second) or the length of the input / output line, take the following preventative measures.
 - * Solution => Provide an inductive filter or line reactor.

11.2. Prevent Noise Effect problem

⚠ WARNING

- Noise generated through the power supply line of the inverter's main or control circuit may badly affect other electronics, in particular, measuring instruments and radios, such as those listed below;
 - => Position Detector, Pressure Sensor, Proximity Switch, AM radio, Telephone.

Solution

- Provide a separate power supply for the inverter and the connected equipment.
- Keep wiring of different types of circuits apart from each other.
- Use shielded wires for weak current and signal circuits and twisted pair wires. for the power supply of weak current signals.
- Provide a noise filter at the incoming power supply circuit of the inverter.

12. Maintenance and Inspection

- Operator shall perform a daily inspection according to this manual and manual 71575-03, including :
 - 1) Does hoist operate according to the push button control?
 - 2) Is there any noise or vibration while operating? Is there any brake slip?
 - 3) Does the limit switch properly operate?
 - 4) Are all warning labels in place and in readable condition?

- If any kind of problem is detected, stop the operation immediately and report it to the person in charge.

▲ DANGER

HAZARDOUS VOLTAGES ARE PRESENT IN THE CONTROL BOX, OTHER ELECTRICAL COMPONENTS, AND CONNECTIONS BETWEEN THESE COMPONENTS.

Before performing ANY mechanical or electrical maintenance on the equipment, de-energize (disconnect) the main switch supplying power to the equipment : and lock and tag the main switch in the de-energized position. Refer to ANSI Z244.1, Personnel Protection - Lockout/ Tagout of Energy Sources. Before checking power supply or electric control parts for hoist, wait 3 minutes before proceeding with any check-ups after shutting down the power.

Do not operate the equipment without control enclosure cover or covers in place.

Only trained and competent personnel should inspect and repair this equipment

- Before turning on the power, make sure that the product has been properly wired without any shorted connections or loose screws.
- Disconnect the inverter unit before performing the insulation resistance or withstand voltage test.

ELECTRIC CHAIN HOIST

13. PARTS ILLUSTRATION FOR INVERTER HOIST

ASSEMBLY PARTS		105	TOP HOOK PIN	244	SPRING WASHER	340	SPRING PIN
①	TOP HOOK ASS'Y	107	HEX NUT	245	BOLT W/HEX	361	ELECTRIC COMPONENT CASE
②	GEAR SIDE PLATE ASS'Y	108	SPRING WASHER	246	SPRING WASHER	362	PACKING,ELECTRIC COMPONENT CASE
③	MOTOR SIDE PLATE ASS'Y	109	COTTER PIN	247	SHACKLE	363	HEX BOLT W/CROSS
④	MOTOR CASE ASS'Y	203	STAY BOLT (A)	252	BALL BEARING	365	ELECTRIC COMPONENT BOARD
⑤	1st GEAR ASS'Y	204	STAY BOLT (B)	253	PACKING,MOTOR CASE	366	BOLT W/HEX
⑥	ELECTRIC EQUIPMENT ASS'Y	205	STAY BOLT (C)	254	PLATE FOR LOCATING	367	SPRING WASHER
⑦	LOAD SHEAVE ASS'Y	206	O RING	258	BOLT W/HEX	368	ADIABATIC PACKING
⑧	SHEAVE COVER ASS'Y	207	HANGER,HOLDING METAL	259	SPRING WASHER	369	PROTECTION RUBBER OF LEAD WIRE
⑨	RATCHET GEAR ASS'Y	211	HEX NUT	303	2nd GEAR	403	SNAP RING
⑩	PAWL ASS'Y	212	SPRING WASHER	304	3rd GEAR	405	CHAIN GUIDE
⑪	ROTOR ASS'Y	232	SUNK BOLT & SEAL	305	4th GEAR	406	ANTI-ROCATING PIN
⑫	BRAKE DISC ASS'Y	233	FLANGE B	322	BALL BEARING	407	ROLLER BOARD
⑬	CORDER HOLDER ASS'Y	234	PACKING,FLANGE B	323	BALL BEARING	408	ROLLER PIN
⑭	BOTTOM HOOK ASS'Y	235	LEAD WIRE	324	PACKING,GEAR CASE	409	ROLLER
⑮	LIMIT SWITCH ASS'Y	236	GEAR CASE	326	OIL PLUG	410	INTERMEDIATE STICK SPRING
⑯	LIMIT CAM SHAFT ASS'Y	238	BALL BEARING	327	OIL PLUG	411	BALL BEARING
⑰	HOLDING METAL	239	OIL SEAL	328	AIR BOLT		
⑱	PUSHBUTTON ASS'Y	240	SNAP RING	329	PACKING,AIR BOLT		
⑲	CHAIN STOPPER ASS'Y	241	BALL BEARING				
⑳	CHAIN BOX ASS'Y	242	EYE BOLT				
㉑	BRAKE COIL ASS'Y	243	HEX NUT				
㉒	INVERTER ASS'Y						
㉓	LOAD LIMITER ASS'Y						

INVERTER TYPE

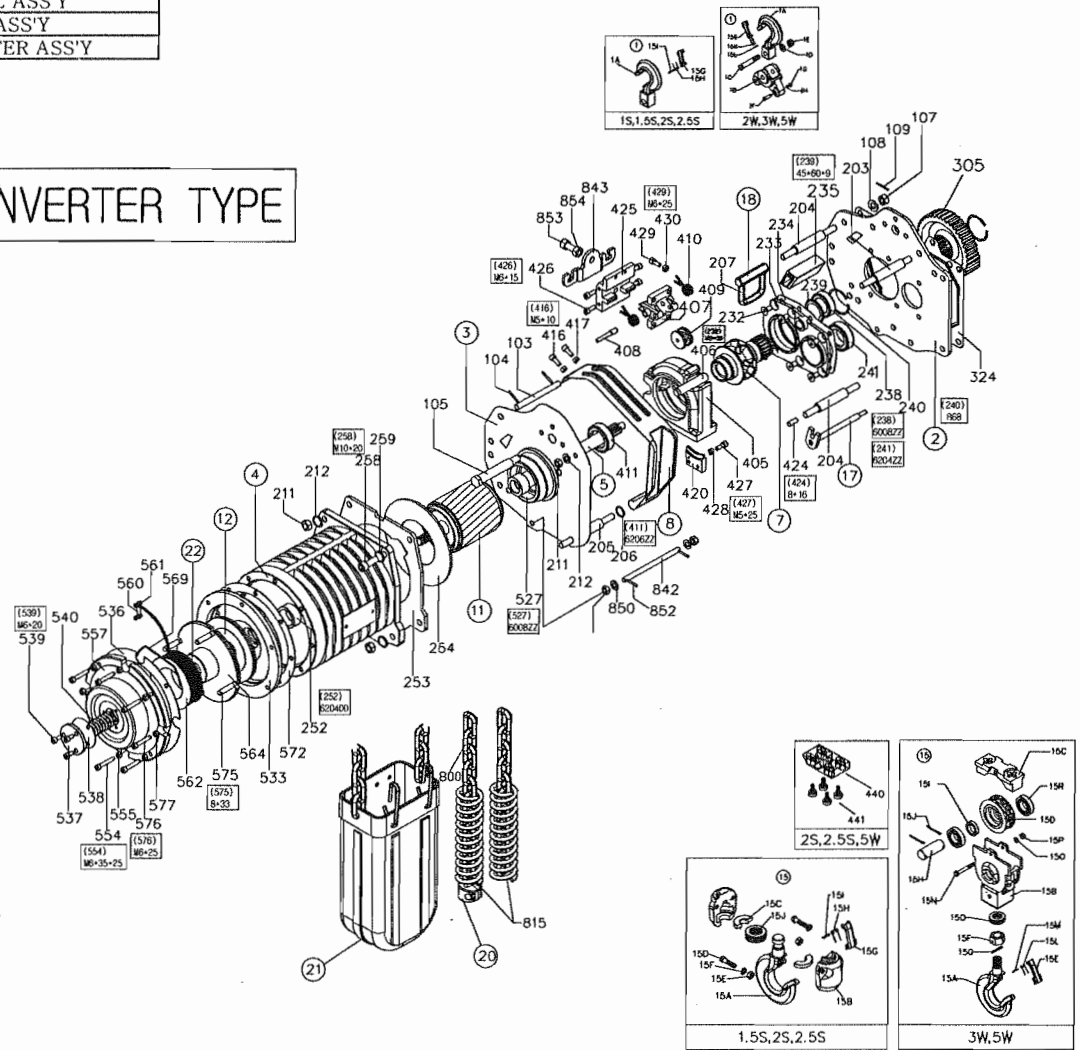

416	BOLT HEX W/HEX
417	SPRING WASHER
420	STRIPPER
424	CORRUGATED SPRING PIN
425	HOLDING BOARD FOR SPRING
427	BOLT W/HEX
428	SPRING WASHER
429	BOLT W/HEX
430	SPRING WASHER
440	CHAIN GUIDE STOPPER
441	BOLT W/HEX

1S,1.5S,2S,2.5S	
(1)	TOP HOOK ASS'Y
1A	TOP HOOK
15G	SAFETY LATCH
15H	SAFETY LATCH SPRING
15I	SAFETY LATCH PIN

2W,3W,5W	
(1)	TOP HOOK ASS'Y
1A	TOP HOOK
1B	ARM
1C	CONNECTING BOLT
1D	PLAIN WASHER
1E	U-NUT
1F	HEX BOLT
1G	U-NUT
1H	SPRING WASHER
15E	SAFETY LATCH
15K	SAFETY LATCH SPRING
15L	SAFETY LATCH PIN

1S,1.5S,2S,2.5S	
(1S)	BOTTOM HOOK ASS'Y
15A	BOTTOM HOOK
15B	BOTTOM HOOK COVER
15C	SPLIT RING
15D	HEX BOLT
15E	HEX NUT
15G	SAFETY LATCH
15H	SAFETY LATCH SPRING
15I	SAFETY LATCH PIN
15J	THRUST BEARING

2W,3W,5W	
(1S)	BOTTOM HOOK ASS'Y
15A	BOTTOM HOOK
15B	BOTTOM HOOK COVER
15C	BOTTOM HOOK CHAIN GUIDE
15D	IDLE SHEAVE
15E	SAFETY LATCH
15F	BOTTOM HOOK NUT
15G	SPRING PIN
15H	IDLE SHEAVE PIN
15I	IDLE SHEAVE COLLAR
15J	COTTER PIN
15K	HOOK NAME PLATE
15L	SAFETY LATCH SPRING
15M	SAFETY LATCH PIN
15N	HEX BOLT
15O	SPRING WASHER
15P	HEX NUT
15Q	THRUST BEARING
15R	CYLINDRICAL ROLLER BEARING

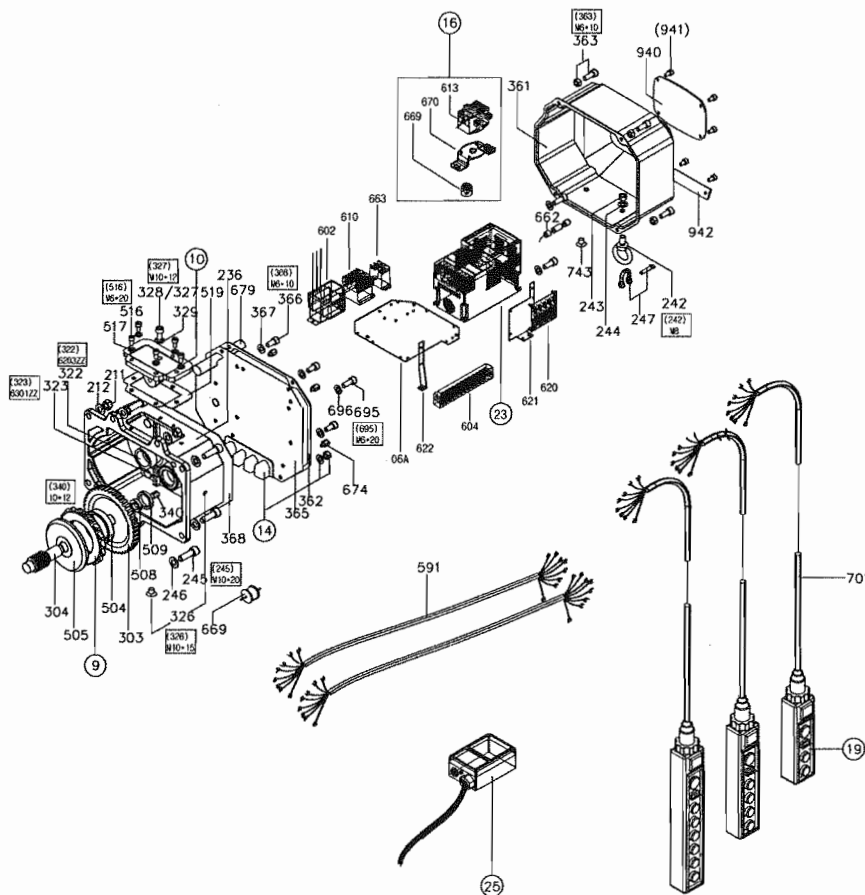

504	BUSH FOR RATCHET DISC
505	DISC HUB
508	SPLIT RING
509	STOPPER RING
516	BOLT W/HEX & SEAL
517	SPRING WASHER
519	PACKING,PAWL COVER
527	BALL BRARING
533	BEARING SUPPORT
536	PACKING,SPRING COVER
537	SPRING COVER
538	PACKING,SPRING COVER
539	HEX NUT
540	BRAKE SPRING
554	BOLT W/HEX & SEAL
555	SPRING WASHER

557	BRAKE STATOR
560	CORD PRESSING METAL
561	SPRING WASHER
562	BRAKE COIL BOBIN
564	MOVING CORE
569	SNAP RING
572	PACKING,BEARING SUPPORT
575	CORRUGATED SPRING PIN
576	BOLT W/HEX
577	SPRING WHASHER
591	CABTIRE CORD
593	SHACKLE
602	TRANS FORMER
604	TERMINAL BLOCK
610	MAGNETIC CONNECTOR
613	LIMIT CAM SWITCH

620	INTERFACE
621	INTER FACE BOARD
622	TERMINAL BLOCK BOARD
662	FUSE
663	CONVERTER
669	JOINT PIPE
670	LIMIT SWITCH BOARD
671	BOLT W/HEX
672	SPRING WASHER
673	PLAIN WASHER
674	HEX STAY PIN
679	GLASS TUBE
695	BOLT W/HEX
696	SPRING WASHER
701	PUSHBUTTON CORD
703	BUSH

707	SHACKLE
708	SUSPENSION CHAIN
743	PLUG
749	HEX STAY PIN
770	CABLE HANGER
800	LOAD CHAIN
815	STOPPER SPRING
842	CHAIN BAG SUPPORT PIN
843	CHAIN SUPPORT METAL
850	PLAIN WASHER
851	HEX NUT
852	COTTER PIN
853	BOLT W/HEX
854	SPRING WASHER
940	NAME PLATE
941	RIVET
942	NAME PLATE 2

13. PARTS ILLUSTRATION FOR INVERTER MOTORIZED TROLLEY

2	GEAR SIDE PLATE
4	SNAP RING
5	PLAIN WASHER
6	Snap ring
8	GEAR ROLLER
9	Ball bearing
10	Snap ring
11	Bolt w/hex, hole
12	Hex Nut
13	GUIDE ROLLER BODY
14	GUIDE ROLLER
15	GUIDE ROLLER PIN
16	BRACKET "A"
17	BRACKET "B"

18	CORD HOLDER ASS'Y
22	PLAIN SIDE PLATE
23	ROLLER PIN
25	Inverter Ass'y
34	Hex, nut
35	SHAFT
36	ADJUSTING COLLAR
37	STOPPER BOLT
38	Cotter pin
39	STOPPER PIN
41	MOTER CASE
42	Stator ASS'Y
43	BRAKE COVER

44	BRAKE SPRING
45	Name Plate
46	H/T W/Remch Bolt
47	Packing
50	Bolt w/hex, hole
54	COVER PLUG
71	GEAR CASE

INVERTER TYPE

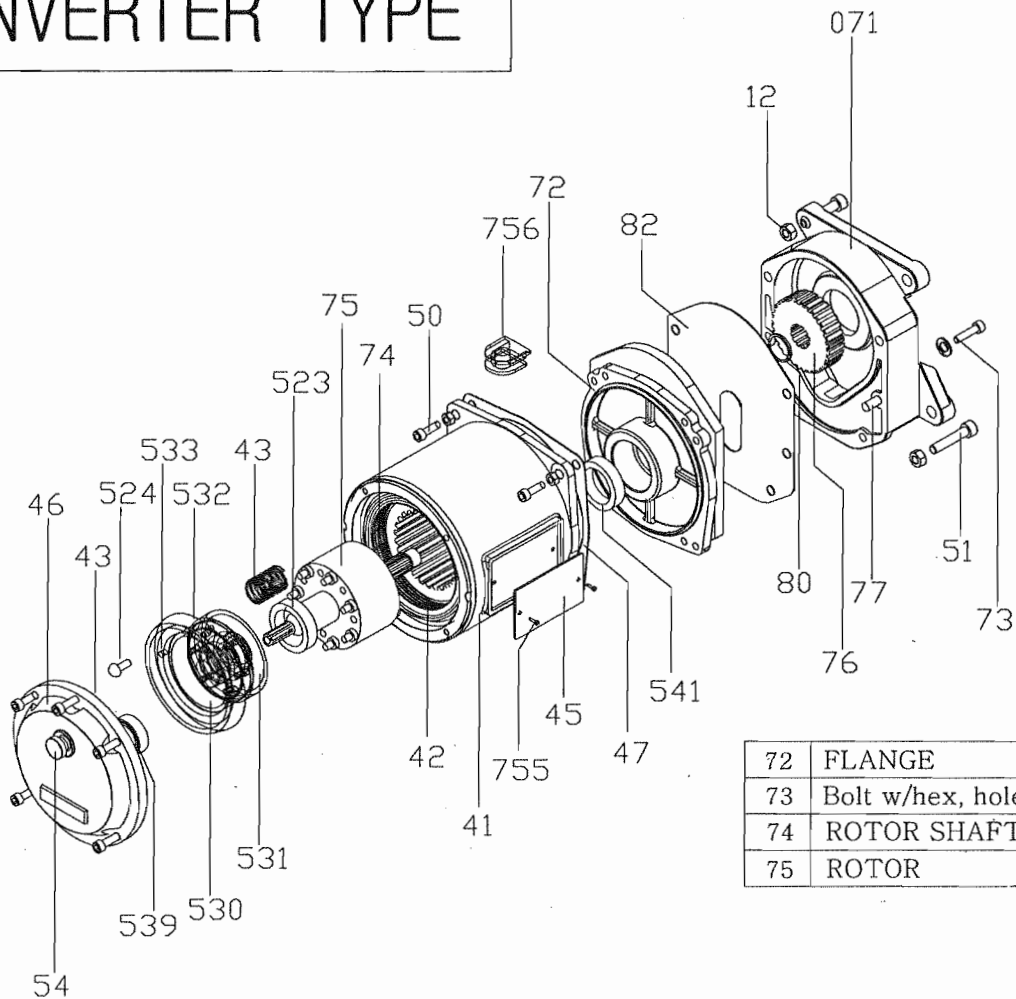

72	FLANGE
73	Bolt w/hex, hole
74	ROTOR SHAFT
75	ROTOR

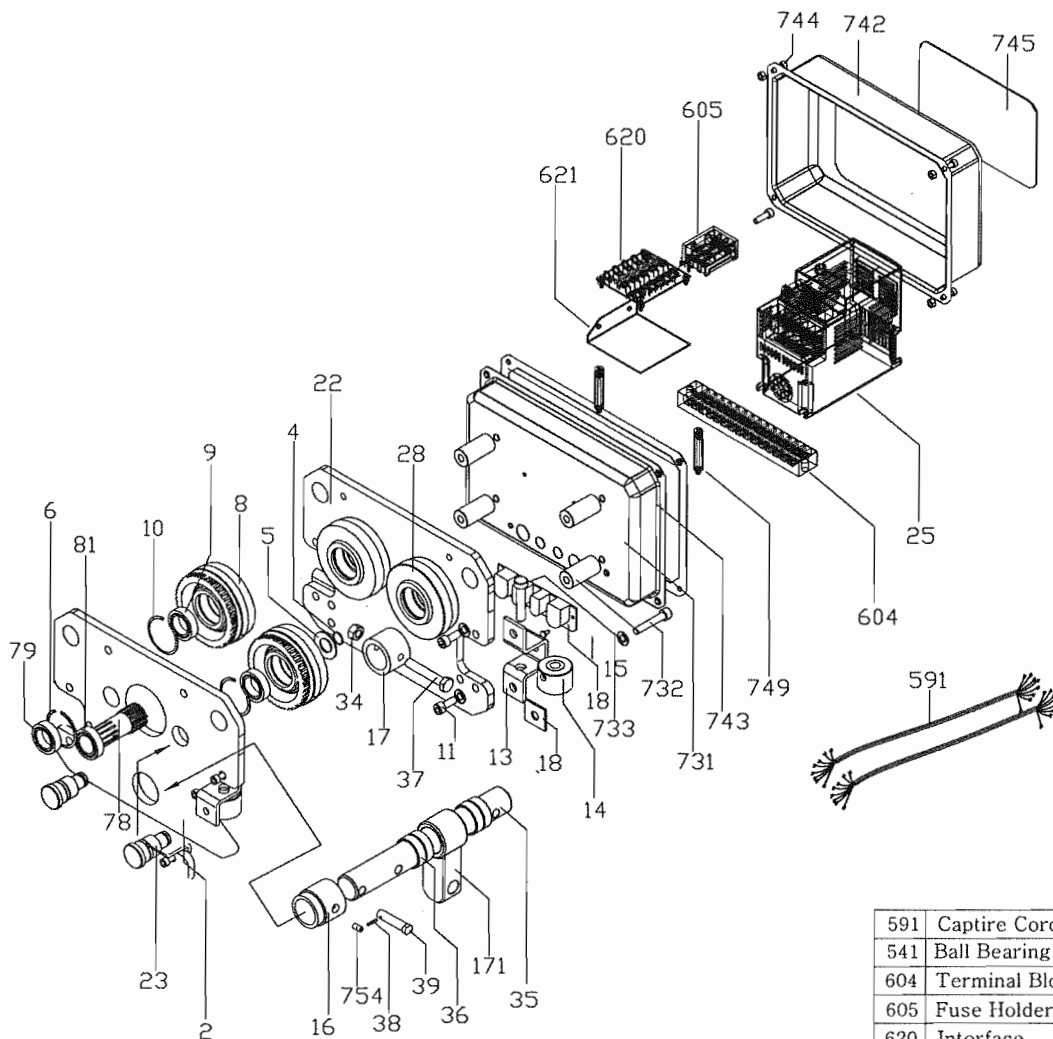

72	FLANGE	76	2'nd gear
73	Bolt w/hex, hole	77	Spring Pin
74	ROTOR SHAFT	78	3rd GEAR
75	ROTOR	79	Ball bearing
		80	Snap Ring
		81	COLLAR FOR 3rd

82	PACKING
171	CONNECTOR
523	BUMPER RUBBEN
524	Rivet
530	BRAKE DISC ASS'Y
531	BRAKE "A"
532	BRAKE LINING
533	SUPPORT PLATE
539	Ball bearing
541	Ball Bearing

591	Captire Cord
541	Ball Bearing
604	Terminal Block
605	Fuse Holder
620	Interface
621	Interface Board
657	Magnet contactor
731	CONTROL BOX
732	Bolt w/hex, hole
733	SUPPORT BAR
742	CONTROL BOX COVER
743	CONTROL BOX PACKING
744	P/H Sems Bolt S/W
745	NAME PLATE
749	Hex Stay Pin
754	Set screw
755	Rivet
756	LEAD PACKING

Except for inverter hoist assembly (no.23), inverter hoist interface (no.620,621), inverter trolley assembly (no.25), inverter interface (no.604,620,621,604), inverter hoist push button (no.19), all other parts are same as illustrated in ACCOLIFT® Electric Chain Hoist Manual 71575-03.

GENERAL CONDITIONS OF WARRANTY

WARRANTIES: The seller warrants to the original using Buyer thereof that the goods sold under this Agreement are free from defects in workmanship and materials for a period of one year from the date of shipment to the original using Buyer. No other express warranties are given and no affirmation of Seller or Seller's agents, by word or action, shall constitute a warranty. No warranty is made for components and accessories made by others when such items are warranted by their respective manufacturers.

Installation or operation of the equipment in any manner other than as recommended by Seller, shall void the warranty.

Any variations in details between the goods furnished herein and those covered in Buyer's specifications are due to standards of manufacture not to be construed as exceptions to the specifications.

DISCLAIMER OF IMPLIED WARRANTIES:

- (a) SELLER MAKES NO WARRANTY OF MERCHANTABILITY IN RESPECT TO THE GOODS SOLD UNDER THIS AGREEMENT.
- (b) This sale is made WITHOUT ANY WARRANTY BY SELLER THAT THE GOODS ARE SUITABLE FOR ANY PARTICULAR PURPOSE.
- (c) Buyer hereby waives all other warranties, guarantees, obligations, liabilities, rights, and remedies arising by law or otherwise including any obligation or liability of the Seller arising from tort, and Buyer shall indemnify Seller from any liability, loss, damage, or claim arising from Buyer's tortious use of the goods sold hereby.

REMEDIES:

- (a) Under no conditions shall any goods be returned to Seller without its prior written consent.
- (b) The Buyer's sole and exclusive remedy for breach of any warranty is limited to Seller furnishing, at its expense, duplicate or repaired parts F.O.B Seller's plant with installation at Buyer's expense if discovery of a claimed defect occurs during the allowable warranty period, and if Seller's inspection determines a defect exists.
- (c) The quantity of material shown by invoice shall in all cases govern settlement for shortages, unless notice of shortage, appropriately documented, is given to the carrier and the Seller upon delivery by the Carrier.
- (d) Claims for errors, deficiencies or imperfections shall be deemed waived by the Buyer unless Seller is notified in writing of the basis of such claims within 10 days after discovery of claimed defect and such discovery occurs within the warranted period.
- (e) Neither Buyer nor User shall be entitled under this Agreement to recover from Seller any incidental or consequential damages of any nature including but not limited to the cost of any labor expended by others in connection with the goods sold hereby by reason of any alleged nonconformity or breach of warranty on the part of the Seller, nor costs of material or account thereof, nor any lost profits whether determinable or speculative.



Acco Material Handling Solutions

76 Acco Drive, Box 792, York, PA 17405-0792
717-741-4863 800-967-7333 Fax 717-741-8572

PART OF THE  FKI GROUP OF COMPANIES

© FKI Industries, Inc.