

ACCOLIFT®

69922

JULY 1994

LEVER HOIST

3/4 - 6 TONS

NOTICE

It is the responsibility of the owner/user to install, inspect, test, maintain, and operate these lever hoists in accordance with ASME B30.21, Safety Standard for Lever Hoists.

These general instructions deal with the normal installation, operation and maintenance situations encountered with the lever hoists described herein. The instructions should not be interpreted to anticipate every possible contingency or to anticipate the final system or configuration that uses these lever hoists. Read and observe the instructions stated in the manual furnished with equipment to be used with these lever hoists.

These instructions include information for a variety of lever hoists. Therefore, all instructions and information may not apply to one specific lever hoist. Disregard those portions of the instructions that do not apply.

If the lever hoist owner/user requires additional information, or if any information in these instructions is not clear, contact Acco Chain & Lifting Products, York, Pennsylvania or the distributor of the lever hoist. Do not install, inspect, test, maintain, or operate this lever hoist unless this information is fully understood.

⚠ WARNING

This lever hoist should not be installed, operated, or maintained by any person who has not read all the contents of these instructions, and ASME B30.21, Safety Standard for Lever Hoists. Failure to read and comply with these instructions or any of the warnings or limitations noted herein can result in serious bodily injury or death, and/or property damage.

Only trained and qualified personnel shall operate and maintain this equipment.

Equipment described herein is not designed for, and should not be used for lifting, supporting, or transporting humans.

User should not use this lever hoist in conjunction with other equipment unless necessary and/or required safety devices applicable to the system are installed by the user.

Modifications to upgrade, rerate or otherwise alter these lever hoists shall be authorized only by the original equipment manufacturer or qualified professional engineer.

PRIOR TO INSTALLATION

Check for damage during shipment. Place claim with carrier if any damage is discovered. DO NOT install or use a damaged lever hoist.

Check and verify that structure or other equipment that will support the lever hoist has a rated load capacity equal to or greater than the rated load capacity of the lever hoist to be used.

⚠ WARNING

SAFETY PRECAUTIONS

1. READ these instructions and ASME B30.21, Safety Standard for Lever Hoists before installing, operating, or maintaining this equipment.
2. DO NOT lift more than rated load.
3. DO NOT operate hoist when it is restricted from forming a straight line with the direction of loading. (Refer to Figure 1)
4. DO NOT operate with twisted, kinked, or damaged chain.
5. DO NOT operate if chain is not seated in sheaves or sprockets.
6. DO NOT wrap chain around load or use chain as a sling.
7. DO NOT operate unless load is properly applied to the saddle or bowl of the hook. (Refer to Figure 1)
8. DO NOT operate if load is applied to the tip of the hook. (Refer to Figure 1)
9. DO NOT operate with damaged or missing hook latches.
10. DO NOT operate hoist when it is in free-wheeling position. (Refer to Figure 2)

11. DO NOT lift people.
12. DO NOT lift or move loads over people.
13. DO NOT operate hoist with lever extensions.
14. DO NOT operate with side-pulling or side-loading of load to hoist.
15. DO NOT operate a damaged or malfunctioning hoist.
16. DO NOT lift or suspend loads with multiple hoists. (Refer to Figure 3)
17. DO NOT remove, deface, or obscure warning label or labels on hoist.
18. DO NOT leave load suspended when hoist is unattended unless specific precautions have been instituted and are in place.
19. WARN personnel of approaching loads.

FIGURE 1

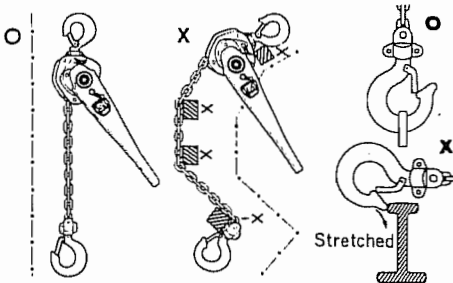

FIGURE 2

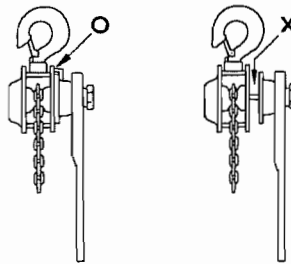
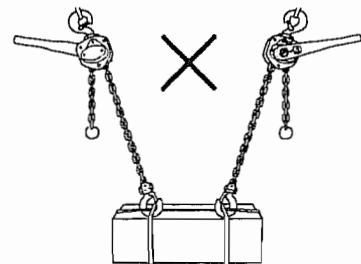

FIGURE 3



OPERATION

To Adjust Chain Length

1. To adjust a short distance, set change lever in central position and turn grip ring by hand. (Refer to Figure 4)
2. For major adjustment:
 - a. Depress retaining pawl with finger and pull grip ring outward. Let pawl return to original position. (Refer to Figure 5)
 - b. Adjust chain freely in either direction. (Refer to Figure 6)
 - c. Terminate free-wheeling as follows:
Set change lever in DOWN position. While depressing retaining pawl as far as it goes, push grip ring gently to let pawl engage outer edge of retaining plate. Grasp ring and handle lever with one hand and push in while rotating handle lever clockwise. Retaining pawl is now in original position and free-wheeling or idling is terminated. (Refer to Figure 7)

FIGURE 4

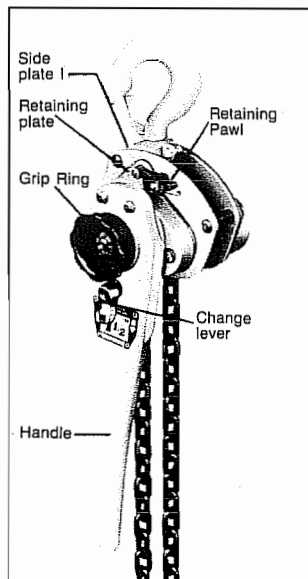

⚠ WARNING

NEVER PUT THE HOIST IN FREE-WHEELING POSITION WHEN A LOAD IS ATTACHED TO THE HOIST; AND NEVER ATTACH A LOAD TO THE HOIST WHEN THE HOIST IS IN FREE-WHEELING POSITION.

FIGURE 5

FIGURE 6

FIGURE 7

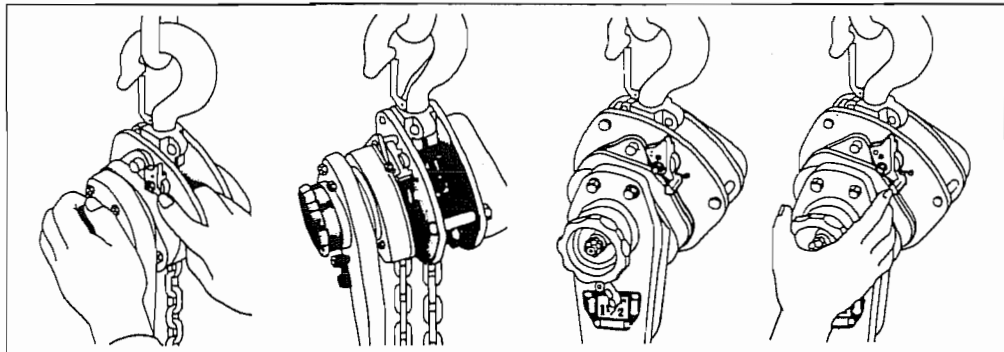

To Operate Lever Hoist

Set change lever in desired direction, UP or DOWN, and operate handle back and forth to move load in desired direction. DO NOT move chain to the extreme end in either direction. Brake is always active, regardless of direction of movement. However, DO NOT attach a load to the hoist when hoist is in free-wheeling mode.

To Test Brake

Lift a light load and set it down a few times to test for brake slippage. If the rotational play of the grip ring is excessive, adjust brake.

DISASSEMBLY, INSPECTION, MAINTENANCE, AND REASSEMBLY

DISASSEMBLY

During disassembly, any parts found to be damaged or having excessive wear must be replaced with new parts during reassembly.

Remove the chain and load block.

1. Disconnect end ring (Item 41) and Warning label (Item 44).
2. Remove chain with hoist in free-wheeling mode.
3. Inspect chain, end ring, warning label, and load hook.

CHAIN

Inspect chain at least once a month. Between regular inspections, check visually daily for nicks, gouges, weld splatter, corrosion, or distorted links. Inspect chain thoroughly if it does not feed smoothly over load sheaves. Inspect as follows:

1. Clean chain with solvent before inspection.
2. Test hoist with load and observe operation of chain over load sheaves.
3. Slacken chain and inspect contact points for excessive wear.
4. Using caliper-type gauge, measure outside length of 11 links under light tension. Replace chain if measurement exceeds maximum allowable gauge length as follows:

CAPACITY TONS	CHAIN WIRE DIAMETER	MAXIMUM ALLOWABLE GAUGE LENGTH
¾	¼ inch	11 links = 8.9 inches
1½	9/32 inch	11 links = 9.8 inches
3	11/32 inch	11 links = 12.6 inches
6	11/32 inch	11 links = 12.6 inches

HOOKS

Refer to ASME B30.10, Safety Standard for Hooks. Inspect hooks and measure hook throat opening at least once a month. Between regular inspections check visually daily for deformation, distortion, twisting, damage, and missing or damaged hook latches. Inspect as follows:

1. Measure hook throat opening from metal to metal of the hook as shown by dimension g in Figure 8. DO NOT measure from latch to metal. Hook must be replaced when throat opening measurement has increased 15% over the original throat opening dimension of a new hook, as follows:

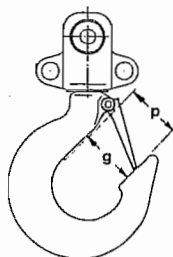

FIGURE 8

CAPACITY TONS	DIMENSION g NEW HOOK	DIMENSION g REPLACE HOOK
¾	1-9/32	1½
1½	1-7/16	1-5/8
3	1-11/16	1-15/16
6	2	2-5/16

2. Measure hook depth at load bearing point (base, bowl, or saddle) of the hook. Hook must be replaced when wear at load bearing point is 10% of the original depth of the hook load bearing point.
3. A bend or twist of the hook exceeding 10° from the plane of the unbent hook requires replacement of the hook.
4. A hook latch, when required, that is missing shall be replaced.
5. A hook latch, when required, that is inoperative shall be repaired or replaced.
6. A hook with a hook latch that does not close the throat opening of the hook shall be removed from service or moused until the latch is replaced or repaired.
7. Hooks having damage from chemicals, corrosion, or deformation shall be repaired or replaced. Damage in the form of cracks, nicks, and gouges may be repaired by a designated person by grinding longitudinally, following the contour of the hook, provided no dimension of the hook is reduced by more than 10% of the original dimension of a new hook. If the repair reduces the dimension of the hook by more than 10% of the original dimension of a new hook, the hook shall be replaced.

NOTICE

ANY HOOK THAT REQUIRES REPLACEMENT BECAUSE OF EXCESSIVE BENDS, TWISTS, OR THROAT OPENING INDICATES ABUSE OR OVERLOADING OF THE HOIST. THEREFORE, OTHER LOAD-SUPPORTING COMPONENTS OF THE HOIST SHOULD BE INSPECTED FOR POSSIBLE DAMAGE WHEN SUCH CONDITIONS ARE FOUND.

CAUTION

NEVER REPAIR HOOKS BY WELDING OR RESHAPING. HEAT APPLIED TO THE HOOK WILL ALTER THE ORIGINAL HEAT TREATMENT OF THE HOOK MATERIAL AND REDUCE THE STRENGTH OF THE HOOK.

NEVER WELD HANDLES OR OTHER ATTACHMENTS TO THE HOOK. HEAT APPLIED TO THE HOOK WILL ALTER THE ORIGINAL HEAT TREATMENT OF THE HOOK MATERIAL AND REDUCE THE STRENGTH OF THE HOOK.

DISASSEMBLY OF HANDLE AND BRAKE

Refer to illustrated parts list, Figure 12. Following the order of parts in the figure, disassemble from right to left.

1. Check handle, grip ring, push pin, brake plate, retaining plate, and hub C-washer for deformation or damage. Replace as required.
2. Check retaining ring and pawl. If pawl is too loose, tighten pawl retaining nut. DO NOT tighten to the point where free movement of the pawl is hindered.

DISASSEMBLY OF GEAR AND BODY

Refer to illustrated parts list, Figure 12. Following the order of parts in the figure, disassemble from left to right. Check gear cover, gears, side plate I, top hook, hook pin, chain guides, chain stripper, load sheave, pinion shaft, and sideplate II for deformation or damage. Replace as required.

REASSEMBLY

Refer to illustrated parts list, Figure 12. Reassemble following the order of parts in the figure.

1. Prior to reassembly, wash or clean all parts as required.
2. Assemble gears. Refer to figures 9 and 10.
 - a. $\frac{3}{4}$ ton: Teeth between two marks on the gear spline (A) must be on horizontal centerline, facing toward center as shown in Figure 9.
 - b. $1\frac{1}{2}$ ton: No precise alignment is required. Gears may be assembled freely.
 - c. 3 and 6 ton: Teeth between two marks on the gear spline (A) must be on horizontal centerline, one facing toward center and one facing outward as shown in Figure 10.
3. DO NOT lubricate the two brake discs (Item 23) or the friction surfaces contacting them.
4. Adjust brake referring to Figure 11.
 - a. Disconnect grip ring.
 - b. With change lever in central position, pull hook end of load chain in the lowering direction. This sets the brake in an engaged position.
 - c. Fit grip ring in such a manner that its projection mark will be aligned with the mark of the change gear.

FIGURE 9

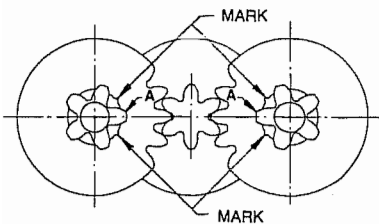

FIGURE 10

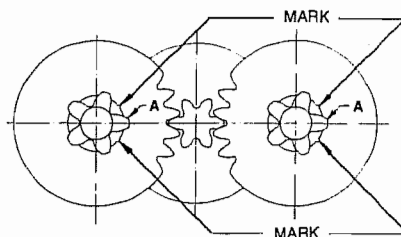
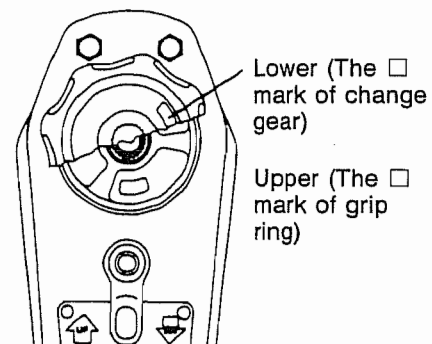

FIGURE 11



LUBRICATION

Apply NLGI No. 2 grease to gears as required.
Lubricate load chain with AGMA No. 2 oil.

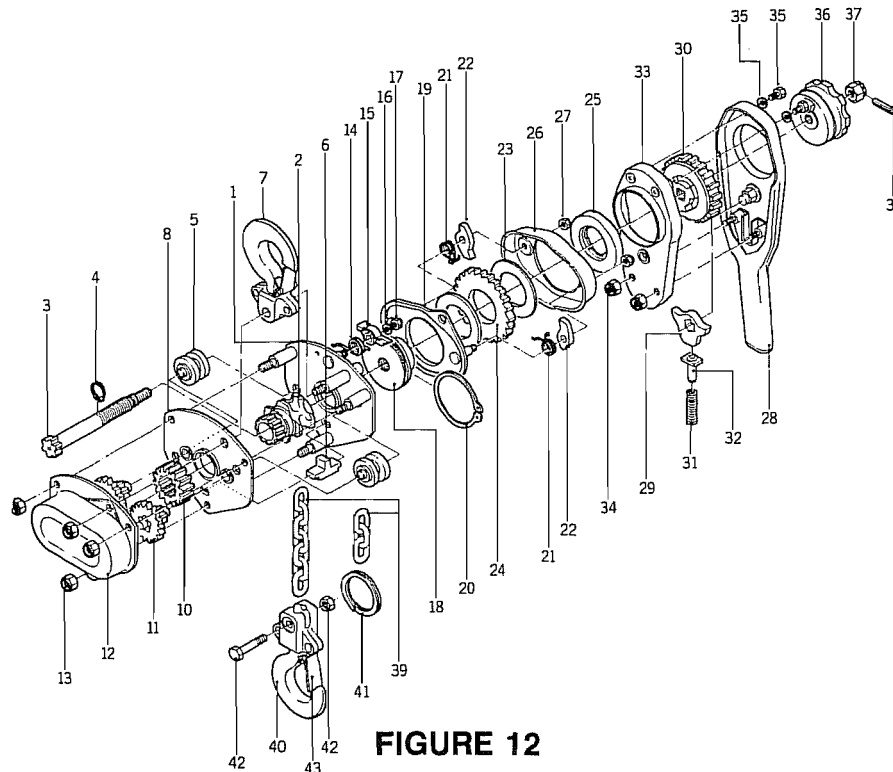

FIGURE 12

ITEM NO.	PART NO.	QUANTITY	PART DESCRIPTION
1	L101S	1	Side Plate I
2	L203	1	Load Sheave
3	L220	1	Pinion Shaft
4	L223	1	C-Washer
5	L109	2	Chain Guide
6	L110	1	Chain Stripper
7	L701S	1	Top Hook Assembly
8	L102S	1	Side Plate II
10	L206	1	1st Gear
11	L207S	2	2nd & 3rd Gear Assembly
12	L108S	1	Gear Cover Assembly
13	L911	4	Gear Cover U-Nut
14	L425	1	Retaining Spring
15	L424	1	Retaining Pawl
16	L423	1	Retaining Pawl Washer
17	L912	1	Retaining Pawl U-Nut
18	L314	1	Hub
19	L422S	1	Retaining Plate Assembly
20	L421	1	Snap Ring
21	L305	2	Brake Spring
22	L304	2	Brake Pawl

ITEM NO.	PART NO.	QUANTITY	PART DESCRIPTION
23	L302	2	Brake Disc
24	L303	1	Ratchet Gear
25	L313	1	Brake Washer
26	L105	1	Brake Cover
27	L912	2	Brake Cover U-Nut
28	L414S	1	Lever Assembly
29	L402	1	Change Pawl
30	L427	1	Change Gear
31	L405	1	Push Spring
32	L404	1	Push Pin
33	L417S	1	Lever Cover
34	L913	2	Lever Cover U-Nut
35	L419	2	Lever Cover Bolt & Washer
36	L428	1	Grip Ring
37	L902	1	Pinion Nut
38	L905	1	Cotter Pin
39	L810	1	Load Chain
40	L709S	1	Load Hook Assembly
41	L756	1	End Ring
42	L705	1	Load Hook Bolt
43	L740	2	Hook Latch
44	68082	1	Warning Label (a)

NOTE:

(a) Not shown. Attached to last chain link on dead side of load chain. Replace if missing or not legible.

NOTICE

TO ORDER PARTS: Provide product name and serial number, lever hoist capacity, part number, part description, and quantity required. Use only Acco® authorized replacement parts in the service and maintenance of this lever hoist.

GENERAL CONDITIONS OF WARRANTY

WARRANTIES: The Seller warrants to the original using Buyer thereof that the goods sold under this Agreement are free from defects in workmanship and materials for a period of one year from the date of shipment to the original using Buyer. No other express warranties are given and no affirmation of Seller or Seller's agents, by word or action, shall constitute a warranty. No warranty is made for components and accessories made by others when such items are warranted by their respective manufacturers.

Installation or operation of the equipment in any manner other than as recommended by Seller, shall void the warranty.

Any variations in details between the goods furnished herein and those covered in Buyer's specifications are due to standards of manufacture not to be construed as exceptions to the specifications.

DISCLAIMER OF IMPLIED WARRANTIES:

- (a) SELLER MAKES NO WARRANTY OF MERCHANTABILITY IN RESPECT TO THE GOODS SOLD UNDER THIS AGREEMENT.
- (b) This sale is made WITHOUT ANY WARRANTY BY SELLER THAT THE GOODS ARE SUITABLE FOR ANY PARTICULAR PURPOSE.
- (c) Buyer hereby waives all other warranties, guarantees, obligations, liabilities, rights, and remedies arising by law or otherwise including any obligation or liability of the Seller arising from tort, and Buyer shall indemnify Seller from any liability, loss, damage, or claim arising from Buyer's tortious use of the goods sold hereby.

REMEDIES:

- (a) Under no conditions shall any goods be returned to Seller without its prior written consent.
- (b) The Buyer's sole and exclusive remedy for breach of any warranty is limited to Seller furnishing, at its expense, duplicate or repaired parts F.O.B. Seller's plant with installation at Buyer's expense if discovery of a claimed defect occurs during the allowable warranty period, and if Seller's inspection determines a defect exists.
- (c) The quantity of material shown by invoice shall in all cases govern settlement for shortages, unless notice of shortage, appropriately documented, is given to the carrier and the Seller upon delivery by the Carrier.
- (d) Claims for errors, deficiencies or imperfections shall be deemed waived by the Buyer unless Seller is notified in writing of the basis of such claims within 10 days after discovery of claimed defect and such discovery occurs within the warranted period.
- (e) Neither Buyer nor User shall be entitled under this Agreement to recover from Seller any incidental or consequential damages of any nature including but not limited to the cost of any labor expended by others in connection with the goods sold hereby by reason of any alleged nonconformity or breach of warranty on the part of the Seller, nor costs of material or account thereof, nor any lost profits whether determinable or speculative.



Acco Chain & Lifting Products Division

76 Acco Drive, Box 792, York, PA 17405-0792
717-741-4863 800-967-7333 Fax 717-741-8572