

Acco[®] WRIGHT[®]

WORK-RATED[®] THE NEW CENTURY SERIES[®]

wire rope electric hoists

product series 34

parts
manual

SERIAL NUMBER

▲ WARNING

This equipment should not be installed, operated or maintained by any person who has not read all the contents of Instruction, Operation, and Maintenance Manual 69833; and Parts Manual 69836. Failure to read and comply with the instructions or any one of the limitations noted in either manual can result in serious bodily injury or death, and/or property damage.

There are no other warranties which extend beyond the description on the Order Acknowledgment and as it may apply to the specifications provided in this publication. THE IMPLIED WARRANTIES OF MERCHANTABILITY AND FITNESS FOR A PARTICULAR PURPOSE ARE EXCLUDED. Acco shall in no event be liable for any special, direct, indirect, incidental or consequential damages to anyone beyond the cost of replacement of the goods sold hereby.

TABLE OF CONTENTS

NOTICE

Parts Manual 69836 covers parts information in reference to Product Series 34 of the WRIGHT® WORK-RATED® THE NEW CENTURY SERIES® wire rope electric hoist line. This manual includes parts information for a variety of hoist types. Therefore, all parts information may not apply to any one type or size of specific hoist. Disregard those portions of the manual that do not apply. Parts Manual 69836 should be used in conjunction with Manual 69833: Installation, Operation, and Maintenance Manual for WRIGHT® WORK-RATED® THE NEW CENTURY SERIES® Wire Rope Electric Hoists. Refer to Manual 69833 for instructions on installation, operation, inspection, testing, adjusting, and maintaining this equipment; and Parts Manual 69836 for parts information and identification. Use of the term MANUAL refers to both Manual 69833 and Parts Manual 69836.

<u>SUBJECT</u>	<u>PAGE</u>
IMPORTANT INFORMATION AND WARNINGS	3
HOIST MOTOR BRAKE ASSEMBLY	5
HOIST GEAR HOUSING ASSEMBLY	6
HOIST MOTOR	8
SUSPENSION - 2PS REEVING	9
SUSPENSION - 4PS REEVING	10
SUSPENSION - 2PD REEVING	11
SUSPENSION - 4PD REEVING	12
LOAD BLOCK - 2PS REEVING	13
LOAD BLOCK - 4PS REEVING	14
LOAD BLOCK - 2PD REEVING	15
LOAD BLOCK - 4PD REEVING	16
GRAVITY LIMIT SWITCH	17
GEARED LIMIT SWITCH	18
HOIST RECTIFIED D.C. BRAKE CONTROL	19
BASIC CONTROL COMPONENTS	20
PENDANT CONTROL STATION	23
2-WHEEL PLAIN TROLLEY - 6 IN. DIA. WHEEL	25
4-WHEEL PLAIN TROLLEY - 6 IN. DIA. WHEEL	26
4-WHEEL GEARED TROLLEY - 6 IN. DIA. WHEEL	27
4-WHEEL GEARED TROLLEY - DUAL DRIVE - 6 IN. DIA. WHEEL	28
LOAD BAR ASSEMBLY FOR RIGID TROLLEYS	29
HAND-GEARED TROLLEY DRIVE	30
MOTORIZED MONORAIL TROLLEY DRIVE	31
MOTORIZED MONORAIL TROLLEY RIGHT-ANGLE REDUCER	32
MOTORIZED TOP-RUNNING TROLLEY DRIVE ASSEMBLY	33
TROLLEY MOTOR BRAKE ASSEMBLY	34
DECK MOUNTED FRAME	35
WINCH UNIT FRAME	35
TOP-RUNNING TROLLEY	36
LOAD BAR ASSEMBLY FOR SWIVELING TROLLEYS	37
OPTIONAL ELECTRICAL CONTROL ENCLOSURE	38

NOTICE

TO ORDER PARTS: Provide part number, part description, quantity required, and Product Number or Serial Number of Hoist.

IMPORTANT INFORMATION AND WARNINGS

CAUTION

These general instructions deal with the normal installation, operation, inspection, and maintenance situations encountered with the equipment described herein. The instructions should not be interpreted to anticipate every possible contingency or to anticipate the final system, crane, or configuration that uses this equipment.

This manual includes instructions and parts information for a variety of hoist types. Therefore, all instructions and parts information may not apply to any one type or size of specific hoist. Disregard those portions of the instructions that do not apply.

Record hoist serial number on the front cover of this manual for identification and future reference to avoid referring to the wrong manual for information or instructions on installation, operation, inspection, maintenance, or parts.

Use only WRIGHT® authorized replacement parts in the service and maintenance of this hoist.

WARNING

Equipment described herein is not designed for and should not be used for lifting, supporting, or transporting humans.

Equipment described herein should not be used in conjunction with other equipment unless necessary and/or required safety devices applicable to the system, crane, or application are installed by the system designer, system manufacturer, crane manufacturer, installer, or user.

Modifications to upgrade, rerate, or otherwise alter this equipment shall be authorized only by the original equipment manufacturer or qualified professional engineer.

Equipment described herein may be used in the design and manufacture of cranes or monorails. Additional equipment or devices may be required for the crane or monorail to comply with applicable crane design and safety standards. The crane designer, crane manufacturer, or user is responsible to furnish these additional items for compliance. Refer to ASME B30.17, Safety Standard for Top-Running Single-Girder Cranes; ASME B30.2 Safety Standard for Top-Running Double-Girder Cranes; and ASME B30.11 Safety Standard for Underhung Cranes and Monorails. If a below-the-hook lifting device or sling is used with a hoist, refer to ASME B30.9, Safety Standard for Slings, or ASME B30.20, Safety Standard for Below-the-Hook Lifting Devices.

Hoists and cranes used to handle hot molten material may require additional equipment or devices. Refer to ANSI Z241.2, Safety Requirements for Melting and Pouring of Metals in the Metalcasting Industry.

Electrical equipment described herein is designed and built in compliance with Acco Chain & Lifting Products interpretation of ANSI/NFPA 70, National Electrical Code. The system designer, system manufacturer, crane designer, crane manufacturer, installer, or user is responsible to assure that the installation and associated wiring of these electrical components is in compliance with ANSI/NFPA 70, and all applicable Federal, State, and Local Codes.

Failure to read and comply with any one of the limitations noted herein can result in serious bodily injury or death, and/or property damage.

DANGER

HAZARDOUS VOLTAGES ARE PRESENT IN THE CONTROL BOX, OTHER ELECTRICAL COMPONENTS, AND CONNECTIONS BETWEEN THESE COMPONENTS.

Before performing ANY mechanical or electrical maintenance on the equipment, de-energize (disconnect) the main switch supplying power to the equipment; and lock and tag the main switch in the de-energized position. Refer to ANSI Z244.1, Personnel Protection – Lockout/Tagout of Energy Sources.

Only trained and competent personnel should inspect and repair this equipment.

IMPORTANT INFORMATION AND WARNINGS

NOTICE

It is the responsibility of the owner/user to install, inspect, test, maintain, and operate a hoist in accordance with ASME B30.16, Safety Standard for Overhead Hoists, OSHA Regulations, and ANSI/NFPA 70, National Electrical Code. If the hoist is installed as part of a total lifting system, such as an overhead crane or monorail, it is also the responsibility of the owner/user to comply with the applicable ASME B30 volume that addresses that type of equipment.

It is the responsibility of the owner/user to have all personnel that will install, inspect, test, maintain, and operate a hoist read the contents of this manual and applicable portions of ASME B30.16, Safety Standard for Overhead Hoists, OSHA Regulations, and ANSI/NFPA 70, National Electrical Code. If the hoist is installed as part of a total lifting system, such as an overhead crane, the applicable ASME B30 volume that addresses that type of equipment must also be read by all personnel.

Any ANSI Standards referenced in this manual may be obtained from the American National Standards Institute, 1430 Broadway, New York, New York 10018.

This manual contains information for safe operation of an overhead hoist. Taking precedence over any specific rule, however, is the most important rule of all - "USE COMMON SENSE." Operation of an overhead hoist involves more than operating the controls. The operator must consider and anticipate the motions and actions that will occur as a result of operating the controls.

If the hoist owner/user requires additional information, or if any information in the manual is not clear, contact Acco Chain & Lifting Products, York, Pennsylvania or the distributor of the hoist. Do not install, inspect, test, maintain, or operate this hoist unless this information is fully understood.

When contacting Acco Chain & Lifting Products or the distributor of the hoist, always make reference to the serial number of the hoist.

A regular schedule of inspection of the hoist in accordance with the requirements of ASME B30.16 should be established and records maintained.

WARNING

Before installing, removing, inspecting, or performing any maintenance on a hoist, the main switch shall be de-energized. Lock and tag the main switch in the de-energized position in accordance with ANSI Z244.1. Follow other maintenance procedures outlined in this manual and applicable ASME B30 volumes.

Additional WARNINGS are listed in various portions of this manual. Personnel shall read and follow these WARNINGS. Failure to read and comply with these WARNINGS as well as other instructions or any limitations noted in this manual and applicable ASME B30 volumes could result in serious bodily injury or death, and/or property damage.

HOIST MOTOR BRAKE ASSEMBLY

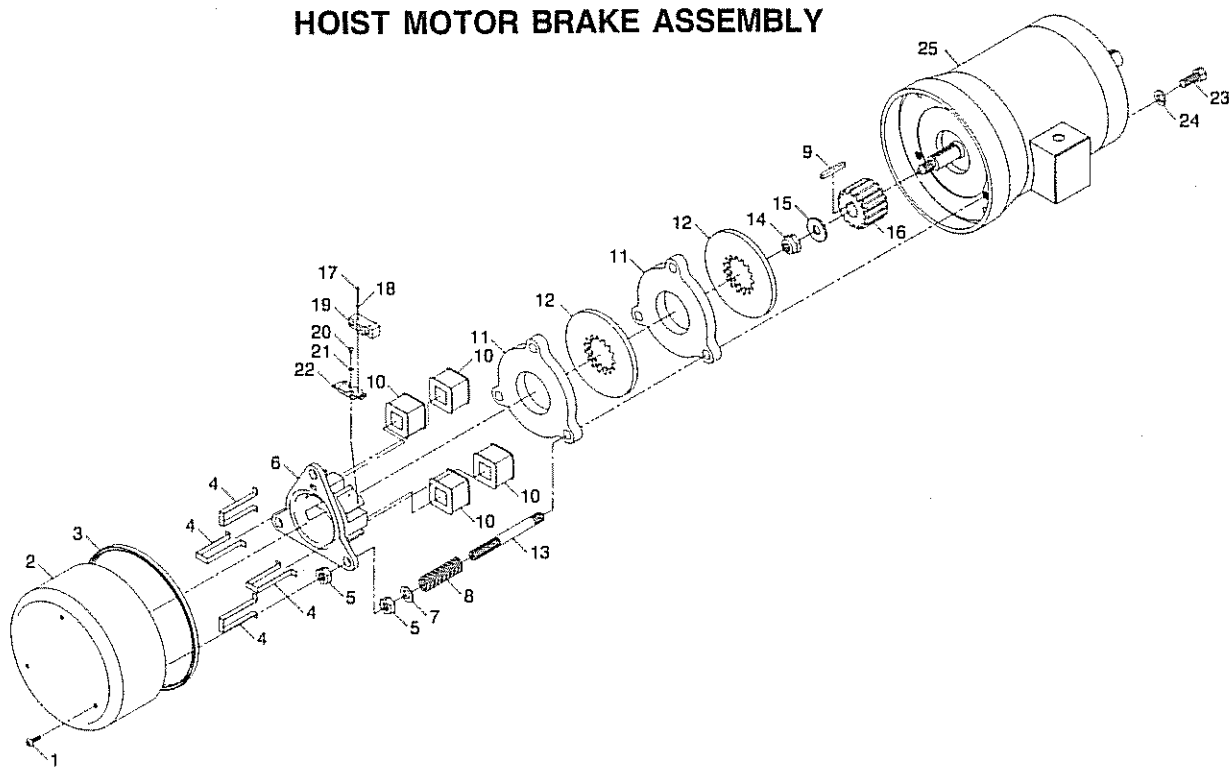

HOIST MOTOR BRAKE PARTS

ITEM NO.	DESCRIPTION	QTY	68 LB FT TORQUE (a)
			69757-21 (b) (c) PART NO.
1	Screw, LOC-WELL (d)	3▲	PA7323
2	Cover	1	69743-03
3	Gasket	3.1ft▲	PA7110
4	Coil Strap	4	51451
5	Nut, Jam	6	24-12C
6	Magnet	1	51447
7	Washer	3	PA5183
8	Spring	3	PA6275 (e)
9	Key	1	(g)
10	Coil	4	51452
11	Armature Plate	2	51443
12	Lining Disc	2▲	51439
13	Stud	3	69991
14	Locknut	1▲	PA2434
15	Washer	1	15-10-0
16	Hub	1	69990
17	Screw	2	3-06-14
18	Lockwasher	2	19-06
19	Switch	1	PA6079
20	Screw	2	3-08-4
21	Lockwasher	2	19-08C
22	Mounting Bracket	1	PA6080
23	Bolt	4	(f)
24	Lockwasher	4	(f)
25	Motor	1	(f)

NOTES:

- (a) On standard hoists, 68 lb. ft. torque brakes are used with single-speed and two-speed 15 HP motors.
- (b) Number in heading of chart is Hoist Motor Brake Assembly number.
- (c) This brake is not used on hoists in Hazardous (Classified) locations as identified by the National Electrical Code.
- (d) Screw with self-locking feature must be utilized. Substitutes are not permissible.
- (e) Springs are color coded. Spring (PA6275) for 68 lb. ft. torque brake is yellow color.
- (f) For part numbers, refer to page 8, Hoist Motor.
- (g) Included with hoist motor.

▲ Recommended Spare Parts

HOIST GEAR HOUSING ASSEMBLY

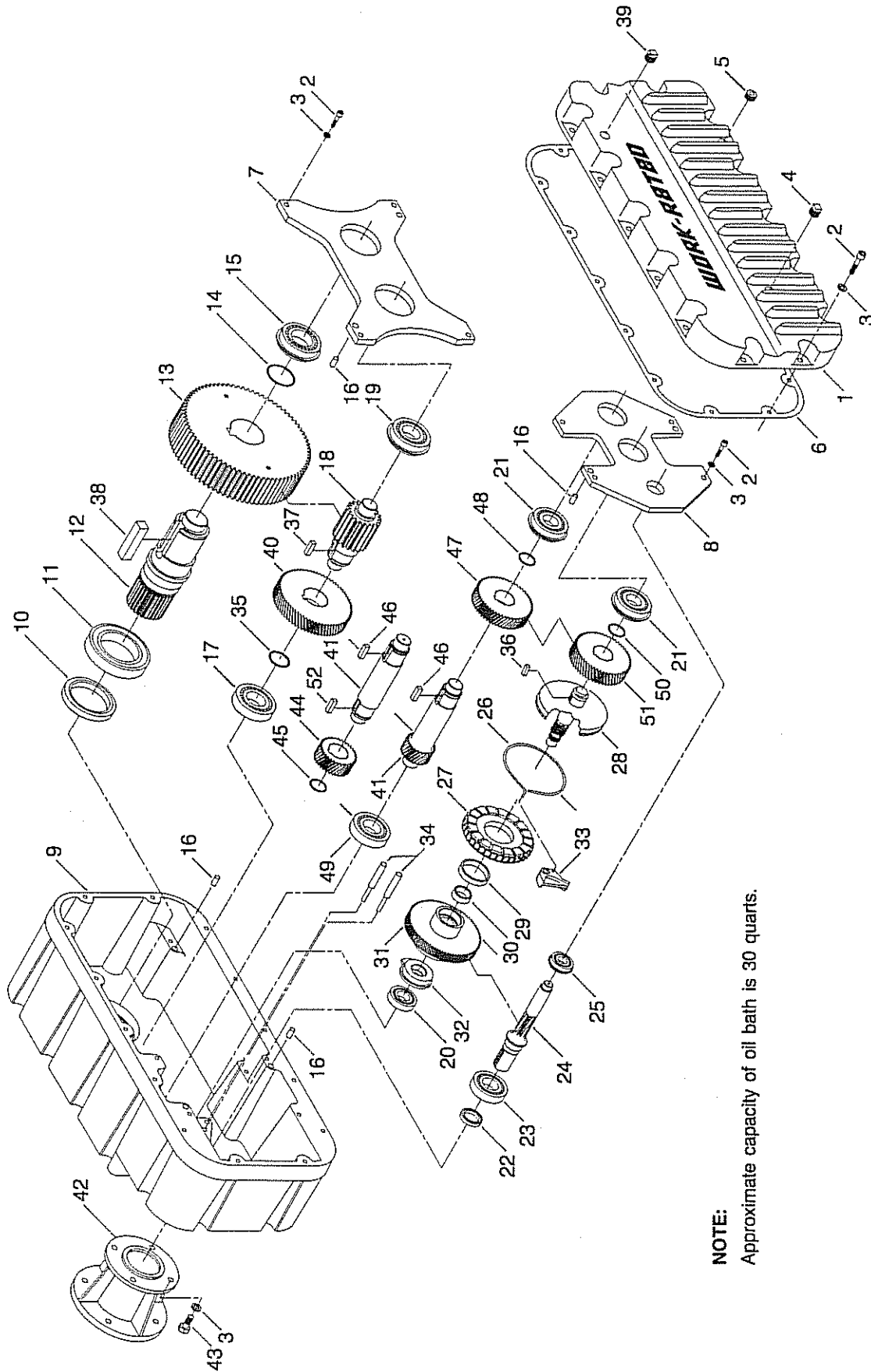

NOTE:
Approximate capacity of oil bath is 30 quarts.

HOIST GEAR HOUSING ASSEMBLY

HOIST GEAR HOUSING PARTS

ITEM NO.	PART NUMBER	DESCRIPTION	QTY/ ASSY
1	70037	Gear Housing Cover	1
2	1-8-24	Bolt, 1/2-13 x 1-1/2	22
3	17-8C	Lockwasher, 1/2	26
4	PA7380	Oil Level Plug	1
5	PA798	Pipe Plug	1
6▲	70039	Gasket	1
7	70041	Output Spider	1
8	70040	Input Spider	1
9	70036	Gear Housing	1
10▲	PA7441	Oil Seal	1
11	PA7439	Bearing	1
12	70045	Drum Shaft	1
13	70047	Drum Gear	1
14	PA7443	Retaining Ring	1
15	PA7440	Bearing	1
16	PA7394	Dowel Pin	4
17	PA7437	Bearing	1
18	70044	Drum Pinion Shaft	1
19	PA7438	Bearing	1
20	PA6563	Bearing	1
21	PA7436	Bearing	2
22▲	PA7442	Oil Seal	1
23	PA7434	Bearing	1
24	70042	Motor Pinion Shaft	1
25	PA7435	Bearing	1
26	54430	Pawl Spring	1

ITEM NO.	PART NUMBER	DESCRIPTION	QTY/ ASSY
27	54343	Ratchet Unit	1
28	55683	Brake Shaft Unit	1
29	PA6289	Needle Bearing, Outer	1
30	PA6290	Needle Bearing, Inner	1
31	55695	Brake Gear	1
32	50564	Check Sleeve	1
33	60799	Pawl	1
34	70131	Pawl Pin	2
35	PA7037	Retaining Ring	1
36	70231	Key	1
37	70057	Key	1
38	70058	Key	1
39	PA7381	Vent Plug	1
40	(a)	Change Gear	(a)
41	(a)	Change Pinion or Shaft	(a)
42	70038	Motor Snout	1
43	35-8-20C	Bolt, 1/2-13 x 1-1/4	4
44	(a)	Change Pinion	(a)
45	(a)	Retaining Ring	(a)
46	70048	Key	1
47	70050	Change Gear	1
48	PA1269	Retaining Ring	1
49	PA6616	Bearing	1
50	PA6144	Retaining Ring	1
51	70049	Change Pinion	1
52	(a)	Key	(a)

NOTE:

(a) Gearing varies with the speed of the hoist. Three gear sets are available, each identified by Gear Housing Assembly No. 70060 with dash number suffix (-01 thru -02). Select proper dash number by counting and comparing number of teeth in gear and pinion.

The parts of this assembly that affect the speed of the hoist are items 40, 41, 44, 45, and 52.

GEAR HOUSING ASSEMBLY			70060-01	70060-02
LIFTING SPEED (2PS/2PD)			30 FPM	44 FPM
LIFTING SPEED (4PS/4PD)			15 FPM	22 FPM
ITEM NO.	PART NO.	DESCRIPTION	QTY.	QTY.
40	70053	Gear, 78 Teeth	1	0
40	70052	Gear, 70 Teeth	0	1
41	70046	Change Pinion, 26 Teeth	1	0
41	70043	Change Shaft	0	1
44	70051	Change Pinion, 34 Teeth	0	1
45	PA1269	Retaining Ring	0	1
52	70056	Key	0	1

▲ Recommended Spare Parts

HOIST MOTOR

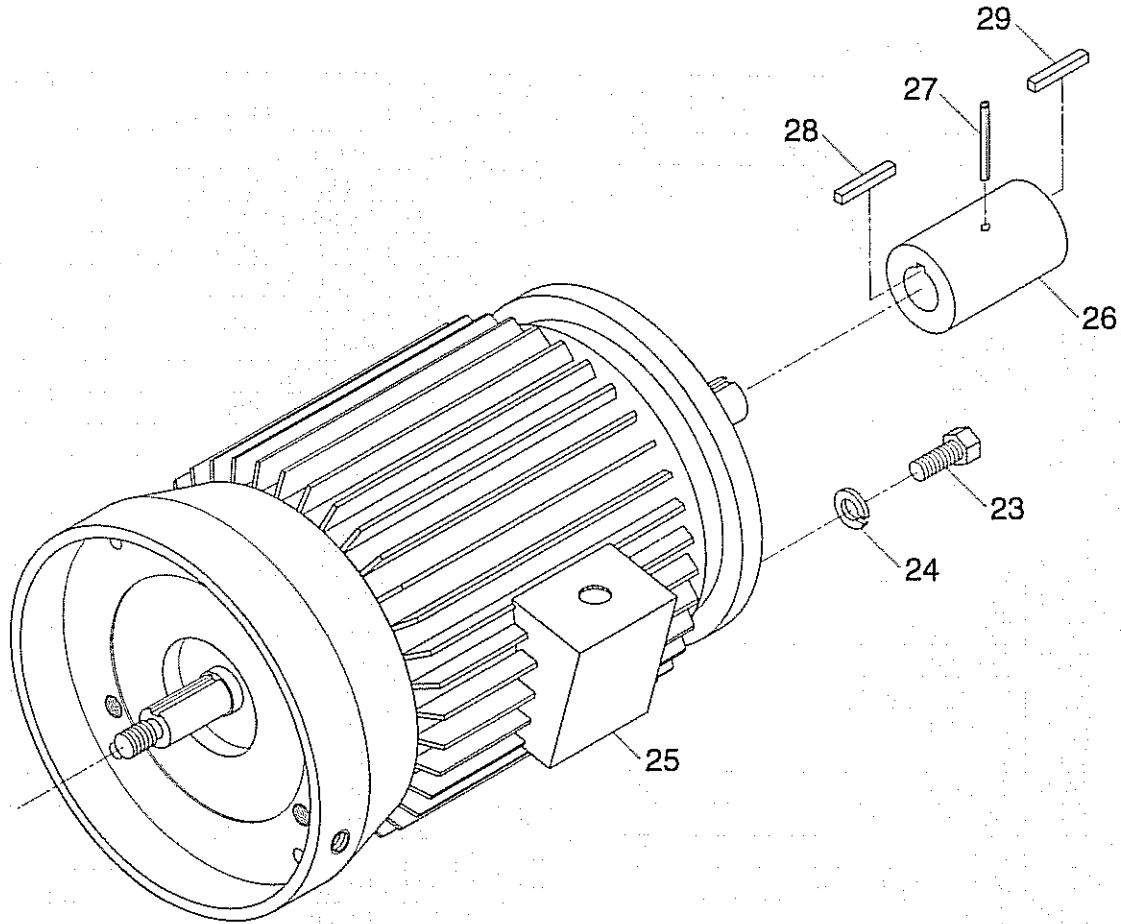

HOIST MOTOR PARTS

ITEM NO.	PART NO.	DESCRIPTION	QTY.
23	35-8-20C	Bolt, Hex Head	4
24	17-8C	Lockwasher	4
25	(b)	Hoist Motor	1
26	70055	Coupling	1
27	PA5366	Roll Pin	1
28	(a)	Key	1
29	70054	Key	1

No Recommended Spare Parts

NOTES:

(a) Included with hoist motor

(b) Select standard hoist motor by part number according to motor specifications as follows:

- Motor part number 69777-13: 15 HP single speed, 1800 rpm, 208 volt, frame 256TC.
 - Motor part number 69777-14: 15 HP single speed, 1800 rpm, 230/460 volt, frame 256TC.
 - Motor part number 69777-15: 15 HP single speed, 1800 rpm, 575 volt, frame 256TC.
 - Motor part number 69778-17: 15/5 HP two speed, 1800/600 rpm, 208 volt, frame 256TC.
 - Motor part number 69778-18: 15/5 HP two speed, 1800/600 rpm, 230 volt, frame 256TC.
 - Motor part number 69778-19: 15/5 HP two speed, 1800/600 rpm, 460 volt, frame 256TC.
 - Motor part number 69778-20: 15/5 HP two speed, 1800/600 rpm, 575 volt, frame 256TC.
- For other specified special motors, refer to additional information pages supplied with manual.

PARTS LIST – PRODUCT SERIES 34

SUSPENSION – 2PS REEVING

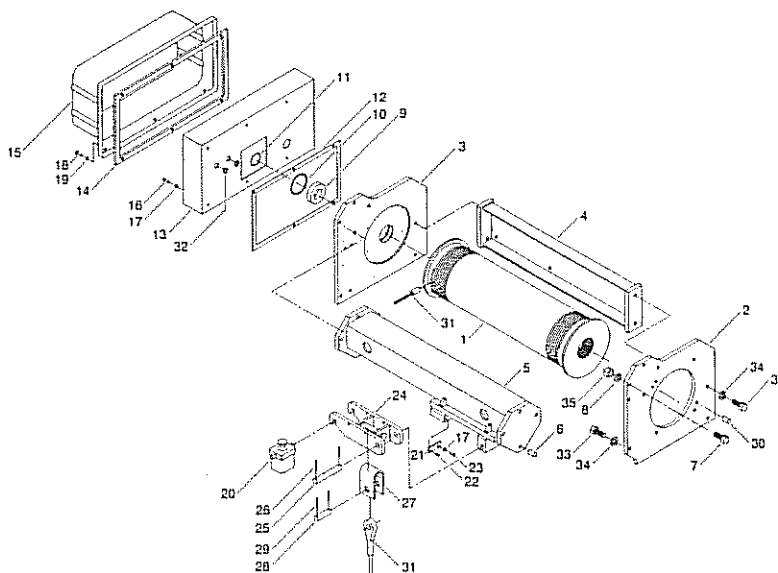

2PS SUSPENSION PARTS

ITEM NO.	DESCRIPTION	QTY.	21 FT. LIFT PART NO.	53 FT. LIFT PART NO.	71 FT. LIFT PART NO.	97 FT. LIFT PART NO.
1	Drum, Single Grooving	1	70144-01	70144-02	70144-03	70144-04
2	End Plate, Gear End	1	70148	70148	70148	70148
3	End Plate, Control End	1	70149	70149	70149	70149
4	Side Frame	1	70172-01	70172-02	70172-03	70172-04
5	Frame Unit	1	70212-01	70212-02	70208-03	70208-04
6	Dowel Pin	4	PA7457	PA7457	PA7457	PA7457
7	Hex Head Bolt	4	35-12-44C	35-12-44C	35-12-44C	35-12-44C
8	Lockwasher	4	17-12C	17-12C	17-12C	17-12C
9	Bearing	1	PA7451	PA7451	PA7451	PA7451
10	Retaining Ring	1	PA7456	PA7456	PA7456	PA7456
11	Retaining Ring	1	PA7455	PA7455	PA7455	PA7455
12	Gasket	1	70139	70139	70139	70139
13	Enclosure	1	70138-01	70138-01	70138-01	70138-01
14	Gasket	1	58531	58531	58531	58531
15	Cover	1	52823	52823	52823	52823
16	Hex Head Bolt	6	35-4-6C	35-4-6C	35-4-6C	35-4-6C
17	Lockwasher	7	17-4C	17-4C	17-4C	17-4C
18	Captive Screw	6	58597	58597	58597	58597
19	Retaining Ring	6	PA6634	PA6634	PA6634	PA6634
20	Overload Cut-off 5 Ton	1	39170-04	39170-04	39170-04	39170-04
20	Overload Cut-off 7½ Ton	1	66291-04	66291-04	66291-04	66291-04
21	Keeper Plate	1	53219	53219	53219	53219
22	Roll Pin	1	PA4607	PA4607	PA4607	PA4607
23	Hex Head Bolt	1	35-4-8C	35-4-8C	35-4-8C	35-4-8C
24	Rope End Mounting Unit	1	69753	69753	69753	69753
25	Pin	1	69717	69717	69717	69717
26	Cotter Pin	2	PA1364	PA1364	PA1364	PA1364
27	Rope Hanger	1	70161	70161	70161	70161
28	Pin	1	70162	70162	70162	70162
29	Cotter Pin	2	PA1771	PA1771	PA1771	PA1771
30	Dowel Pin	2	PA7458	PA7458	PA7458	PA7458
31	Wire Rope Assembly (a)	1 ▲	70146-01	70146-02	70146-03	70146-04
32	Grommet	2	PA7409	PA7409	PA7409	PA7409
33	Hex Head Bolt	10	35-10-28C	35-10-28C	35-10-28C	35-10-28C
34	Lockwasher	10	17-10C	17-10C	17-10C	17-10C
35	Hex Nut	4	22-12C	22-12C	22-12C	22-12C

▲ Recommended Spare Parts

NOTE: (a) Part numbers shown for Item 31, Wire Rope Assembly, are for standard hoists using 5/8 dia. 6x37 XIP wire rope. For special hoists using other size or type wire rope, refer to the wire rope part number listed in additional pages included with this manual; or contact Acco Chain & Lifting Products or the distributor of the hoist.

SUSPENSION – 4PS REEVING

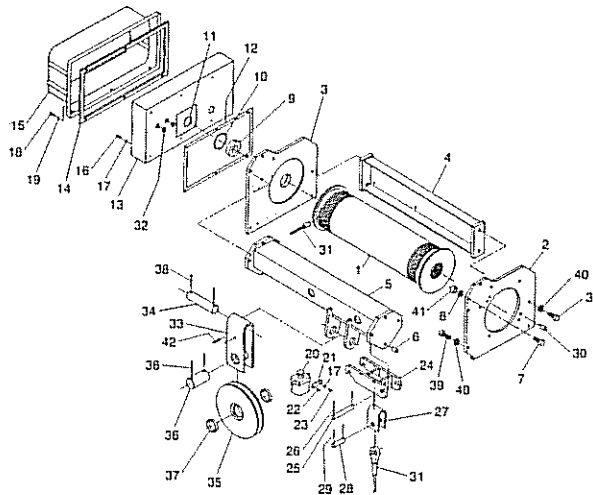

4PS SUSPENSION PARTS

ITEM NO.	DESCRIPTION	QTY.	25 FT. LIFT PART NO.	38 FT. LIFT PART NO.	61 FT. LIFT PART NO.	92 FT. LIFT PART NO.
1	Drum, Single Grooving	1	70144-03	70144-04	70144-05	70144-06
2	End Plate, Gear End	1	70148	70148	70148	70148
3	End Plate, Control End	1	70149	70149	70149	70149
4	Side Frame	1	70172-03	70172-04	70172-05	70172-06
5	Frame Unit	1	70169-03	70169-04	70169-05	70169-06
6	Dowel Pin	4	PA7457	PA7457	PA7457	PA7457
7	Hex Head Bolt	4	35-12-44C	35-12-44C	35-12-44C	35-12-44C
8	Lockwasher	4	17-12C	17-12C	17-12C	17-12C
9	Bearing	1	PA7451	PA7451	PA7451	PA7451
10	Retaining Ring	1	PA7456	PA7456	PA7456	PA7456
11	Retaining Ring	1	PA7455	PA7455	PA7455	PA7455
12	Gasket	1	70139	70139	70139	70139
13	Enclosure	1	70138-01	70138-01	70138-01	70138-01
14	Gasket	1	58531	58531	58531	58531
15	Cover	1	52823	52823	52823	52823
16	Hex Head Bolt	6	35-4-6C	35-4-6C	35-4-6C	35-4-6C
17	Lockwasher	7	17-4C	17-4C	17-4C	17-4C
18	Captive Screw	6	58597	58597	58597	58597
19	Retaining Ring	6	PA6634	PA6634	PA6634	PA6634
20	Overload Cut-off 10 Ton	1	39170-04	39170-04	39170-04	39170-04
20	Overload Cut-off 15 Ton	1	66291-04	66291-04	66291-04	66291-04
21	Keeper Plate	1	53219	53219	53219	53219
22	Roll Pin	1	PA4607	PA4607	PA4607	PA4607
23	Hex Head Bolt	1	35-4-8C	35-4-8C	35-4-8C	35-4-8C
24	Rope End Mounting Unit	1	69753	69753	69753	69753
25	Pin	1	69717	69717	69717	69717
26	Cotter Pin	2	PA1364	PA1364	PA1364	PA1364
27	Rope Hanger	1	70161	70161	70161	70161
28	Pin	1	70162	70162	70162	70162
29	Cotter Pin	2	PA1771	PA1771	PA1771	PA1771
30	Dowel Pin	2	PA7458	PA7458	PA7458	PA7458
31	Wire Rope Assembly (a)	1▲	70146-13	70146-14	70146-15	70146-16
32	Grommet	2	PA7409	PA7409	PA7409	PA7409
33	Sheave Hanger	1	70158	70158	70158	70158
34	Pin	1	70159	70159	70159	70159
35	Polyamide Sheave with Bearing	1	69573	69573	69573	69573
35	Steel Sheave with Bearing	1	69574	69574	69574	69574
36	Pin	1	70160	70160	70160	70160
37	Spacer	2	69575-02	69575-02	69575-02	69575-02
38	Cotter Pin	4	PA1484	PA1484	PA1484	PA1484
39	Hex Head Bolt	10	35-10-28C	35-10-28C	35-10-28C	35-10-28C
40	Lockwasher	10	17-10C	17-10C	17-10C	17-10C
41	Hex Nut	4	22-12C	22-12C	22-12C	22-12C
42	Pin	1	PA3713	PA3713	PA3713	PA3713

▲ Recommended Spare Parts

NOTE: (a) Part numbers shown for Item 31, Wire Rope Assembly, are for standard hoists using 5/8 dia. 6x37 XIP wire rope. For special hoists using other size or type wire rope, refer to the wire rope part number listed in additional pages included with this manual; or contact Acco Chain & Lifting Products or the distributor of the hoist.

PARTS LIST – PRODUCT SERIES 34

SUSPENSION – 2PD REEVING

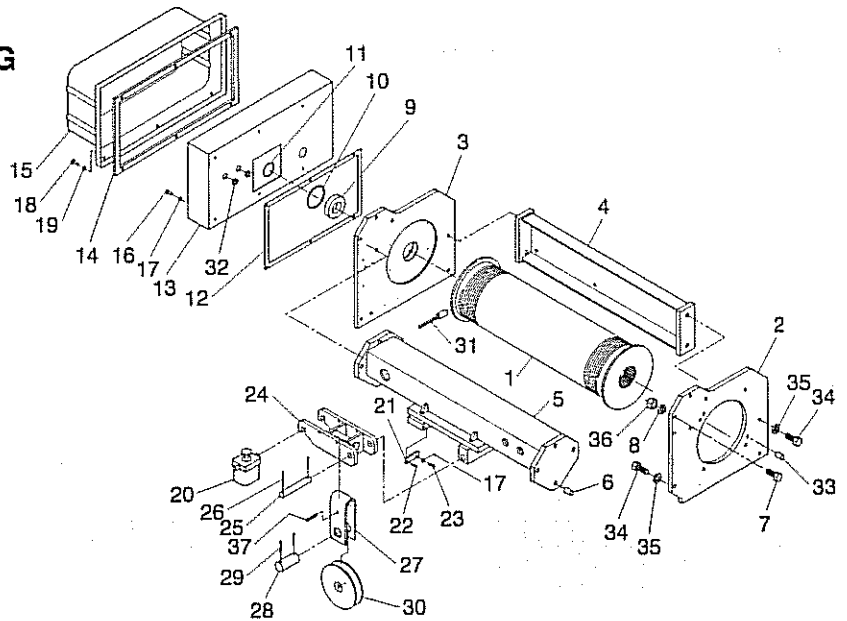

2PD SUSPENSION PARTS

ITEM NO.	DESCRIPTION	QTY.	20 FT. LIFT PART NO.	31 FT. LIFT PART NO.	47 FT. LIFT PART NO.	76 FT. LIFT PART NO.
1	Drum, Double Grooving	1	70145-02	70145-03	70145-04	70145-05
2	End Plate, Gear End	1	70148	70148	70148	70148
3	End Plate, Control End	1	70149	70149	70149	70149
4	Side Frame	1	70172-02	70172-03	70172-04	70152-05
5	Frame Unit	1	70209-02	70209-03	70209-04	70209-05
6	Dowel Pin	4	PA7457	PA7457	PA7457	PA7457
7	Hex Head Bolt	4	35-12-44C	35-12-44C	35-12-44C	35-12-44C
8	Lockwasher	4	17-12C	17-12C	17-12C	17-12C
9	Bearing	1	PA7451	PA7451	PA7451	PA7451
10	Retaining Ring	1	PA7456	PA7456	PA7456	PA7456
11	Retaining Ring	1	PA7455	PA7455	PA7455	PA7455
12	Gasket	1	70139	70139	70139	70139
13	Enclosure	1	70138-01	70138-01	70138-01	70138-01
14	Gasket	1	58531	58531	58531	58531
15	Cover	1	52823	52823	52823	52823
16	Hex Head Bolt	6	35-4-6C	35-4-6C	35-4-6C	35-4-6C
17	Lockwasher	7	17-4C	17-4C	17-4C	17-4C
18	Captive Screw	6	58597	58597	58597	58597
19	Retaining Ring	6	PA6634	PA6634	PA6634	PA6634
20	Overload Cut-off 5 Ton	1	39170-04	39170-04	39170-04	39170-04
20	Overload Cut-off 7½ Ton	1	66291-04	66291-04	66291-04	66291-04
21	Keeper Plate	1	53219	53219	53219	53219
22	Roll Pin	1	PA4607	PA4607	PA4607	PA4607
23	Hex Head Bolt	1	35-4-8C	35-4-8C	35-4-8C	35-4-8C
24	Sheave Mounting Unit	1	69753	69753	69753	69753
25	Pin	1	69717	69717	69717	69717
26	Cotter Pin	2	PA1364	PA1364	PA1364	PA1364
27	Sheave Hanger	1	70059	70059	70059	70059
28	Pin	1	69747	69747	69747	69747
29	Cotter Pin	2	PA1771	PA1771	PA1771	PA1771
30	Polyamide Equalizing Sheave with Bearing	1	70150	70150	70150	70150
30	Steel Equalizing Sheave with Bearing	1	70199	70199	70199	70199
31	Wire Rope Assembly (a)	1▲	70147-02	70147-03	70147-04	70147-05
32	Grommet	2	PA7409	PA7409	PA7409	PA7409
33	Dowel Pin	2	PA7458	PA7458	PA7458	PA7458
34	Hex Head Bolt	10	35-10-28C	35-10-28C	35-10-28C	35-10-28C
35	Lockwasher	10	17-10C	17-10C	17-10C	17-10C
36	Hex Nut	4	22-12C	22-12C	22-12C	22-12C
37	Pin	1	PA5342	PA5342	PA5342	PA5342

▲ Recommended Spare Parts

NOTE: (a) Part numbers shown for Item 31, Wire Rope Assembly, are for standard hoists using 1/2 dia. 6x37 XIP wire rope. For special hoists using other size or type wire rope, refer to the wire rope part number listed in additional pages included with this manual; or contact Acco Chain & Lifting Products or the distributor of the hoist.

PARTS LIST - PRODUCT SERIES 34

SUSPENSION - 4PD REEVING

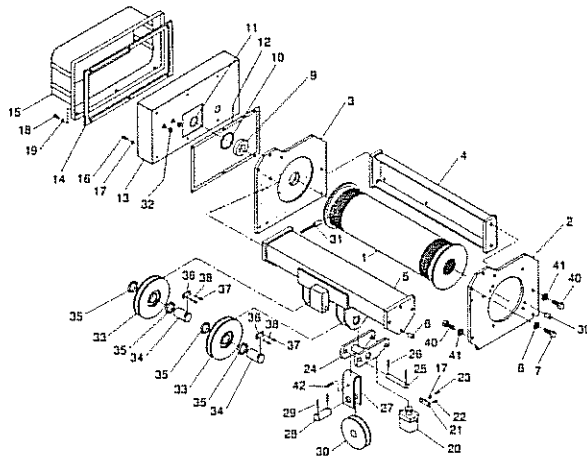

4PD SUSPENSION PARTS

ITEM NO.	DESCRIPTION	QTY.	20 FT. LIFT PART NO.	35 FT. LIFT PART NO.	54 FT. LIFT PART NO.
1	Drum, Double Grooving	1	70145-04	70145-05	70145-06
2	End Plate, Gear End	1	70148	70148	70148
3	End Plate, Control End	1	70149	70149	70149
4	Side Frame	1	70172-04	70172-05	70172-06
5	Frame Unit	1	70194-04	70194-05	70194-06
6	Dowel Pin	4	(b)	(b)	(b)
7	Hex Head Bolt	4	35-12-32C	35-12-32C	35-12-32C
8	Lockwasher	4	17-12C	17-12C	17-12C
9	Bearing	4	PA7451	PA7451	PA7451
10	Retaining Ring	1	PA7456	PA7456	PA7456
11	Retaining Ring	1	PA7455	PA7455	PA7455
12	Gasket	1	70139	70139	70139
13	Enclosure	1	70138-01	70138-01	70138-01
14	Gasket	1	58531	58531	58531
15	Cover	1	52823	52823	52823
16	Hex Head Bolt	6	35-4-6C	35-4-6C	35-4-6C
17	Lockwasher	7	17-4C	17-4C	17-4C
18	Captive Screw	6	58597	58597	58597
19	Retaining Ring	6	PA6634	PA6634	PA6634
20	Overload Cut-off 10 Ton	1	39170-04	39170-04	39170-04
20	Overload Cut-off 15 Ton	1	66291-04	66291-04	66291-04
21	Keeper Plate	1	53219	53219	53219
22	Roll Pin	1	PA4607	PA4607	PA4607
23	Hex Head Bolt	1	35-4-8C	35-4-8C	35-4-8C
24	Sheave Mounting Unit	1	69959	69959	69959
25	Pin	1	69717	69717	69717
26	Cotter Pin	2	PA1364	PA1364	PA1364
27	Sheave Hanger	1	70059	70059	70059
28	Pin	1	69747	69747	69747
29	Cotter Pin	2	PA1771	PA1771	PA1771
30	Polyamide Equalizing Sheave with Bearing	1	70150	70150	70150
30	Steel Equalizing Sheave with Bearing	1	70199	70199	70199
31	Wire Rope Assembly (a)	1▲	70147-14	70147-15	70147-16
32	Grommet	2	PA7409	PA7409	PA7409
33	Polyamide Running Sheave with Bearing	2	69567	69567	69568
33	Steel Running Sheave with Bearing	2	69568	69568	69568
34	Axle	2	69686-02	69686-02	69686-02
35	Spacer	4	69569-02	69569-02	69569-02
36	Keeper Plate	2	50733	50733	50733
37	Screw	4	1-01-8	1-01-8	1-01-8
38	Lockwasher	4	17-010C	17-010C	17-010C
39	Dowel Pin	2	PA7458	PA7458	PA7458
40	Hex Head Bolt	10	35-10-28C	35-10-28C	35-10-28C
41	Lockwasher	10	17-10C	17-10C	17-10C
42	Pin	1	PA5342	PA5342	PA5342

▲ Recommended Spare Parts

NOTES: (a) Part numbers shown for Item 31, Wire Rope Assembly, are for standard hoists using 1/2 dia. 6x37 XIP wire rope. For special hoists using other size or type wire rope, refer to the wire rope part number listed in additional pages included with this manual; or contact Acco Chain & Lifting Products or the distributor of the hoist.

(b) PA7487 except for winch. For winch, use PA7457.

**LOAD BLOCK – 2PS REEVING
5/8" ROPE DIAMETER**

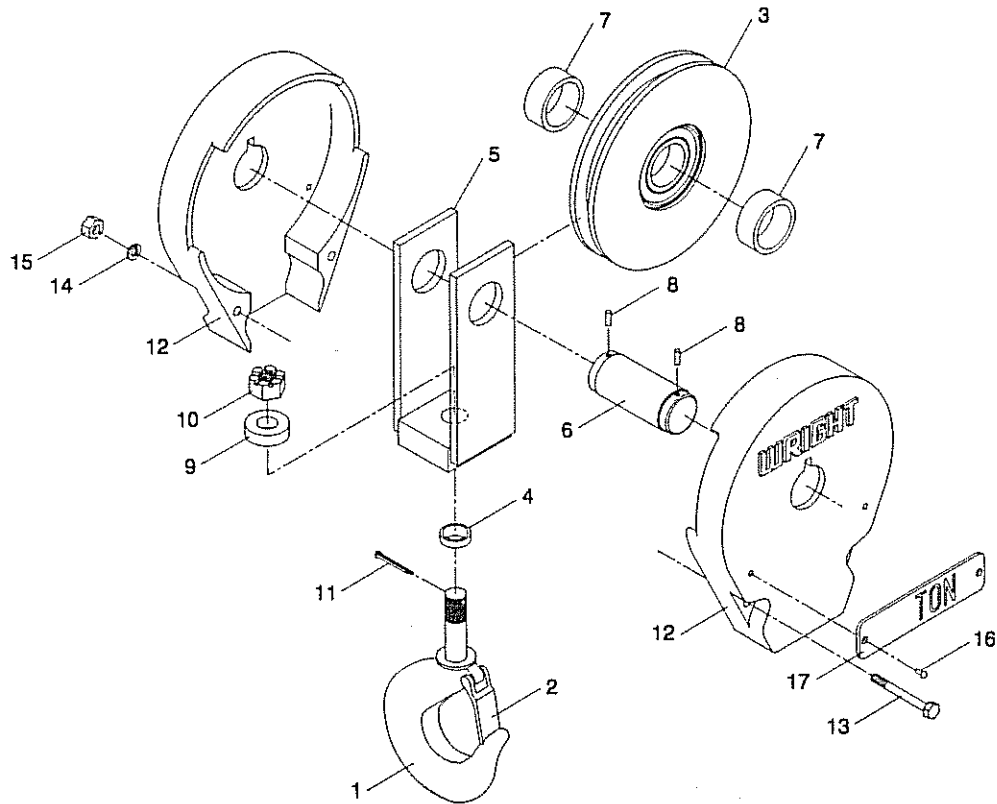

- Load Block Assembly 69552-01 – Acco Spring Latch Type Hook, Polyamide Sheave
- Load Block Assembly 69552-02 – Bullard Swivel Latch Type Hook, Polyamide Sheave
- Load Block Assembly 69552-03 – Bronze Spring Latch Type Hook, Polyamide Sheave
- Load Block Assembly 69552-04 – Acco Spring Latch Type Hook, Steel Sheave
- Load Block Assembly 69552-05 – Bullard Swivel Latch Type Hook, Steel Sheave
- Load Block Assembly 69552-06 – Bronze Spring Latch Type Hook, Steel Sheave

LOAD BLOCK PARTS

ITEM NO.	DESCRIPTION	QUANTITY	PART NO.
1	Hook	1	(a)
2	Latch	1	(b)
3	Sheave	1	(c)
4	Spacer	0	(d)
5	Frame	1	69571
6	Axle	1	69572
7	Spacer	2	69575
8	Roll Pin	2	PA4607
9	Thrust Bearing	1	PA5832
10	Slotted Hex Nut	1	26-24
11	Cotter Pin	1	PA1932
12	Cover	2	58008
13	Hex Head Bolt	2	35-8-52
14	Lockwasher	2	17-8C
15	Hex Nut	2	22-8
16	Drive Screw	4	PA893
17	Capacity Plate	2	(e)

NOTES:

- (a) Hook part numbers:
 Acco Spring Latch Type Hook58012
 Bullard Swivel Latch Type Hook58013
 Bronze Spring Latch Type Hook58014
- (b) Latch part numbers:
 Latch for Acco Spring Latch Type HookPA5327
 No latch required for Bullard Swivel Latch Type Hook
 Latch for Bronze Spring Latch Type Hook ..PA5329
- (c) Sheave part numbers:
 Polyamide sheave with bearing69573
 Steel sheave with bearing.....69574
- (d) Item 4 not required.
- (e) Capacity Plate part numbers:
 5 Ton - 69683-050
 7½ Ton - 69683-075

No Recommended Spare Parts

**LOAD BLOCK – 4PS REEVING
5/8" ROPE DIAMETER**

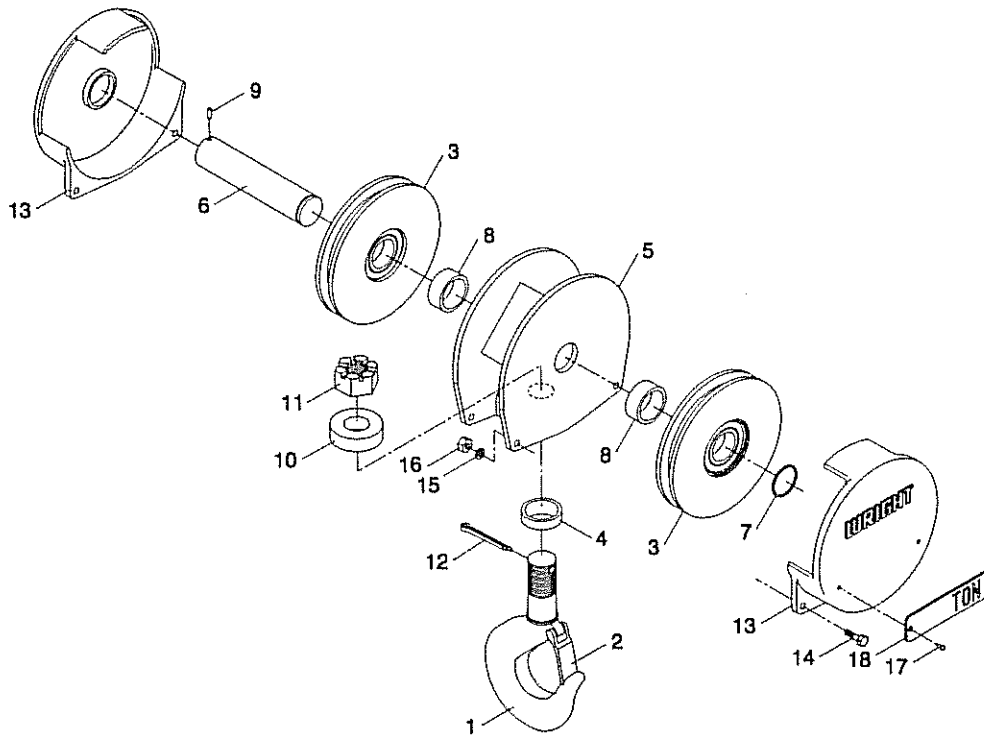

- Load Block Assembly 69556-01 – Acco Spring Latch Type Hook, Polyamide Sheave
- Load Block Assembly 69556-02 – Bullard Swivel Latch Type Hook, Polyamide Sheave
- Load Block Assembly 69556-03 – Acco Spring Latch Type Hook, Steel Sheave
- Load Block Assembly 69556-04 – Bullard Swivel Latch Type Hook, Steel Sheave

LOAD BLOCK PARTS

ITEM NO.	DESCRIPTION	QUANTITY	PART NO.
1	Hook	1	(a)
2	Latch	1	(b)
3	Sheave	2	(c)
4	Spacer	0	(d)
5	Frame	1	69597
6	Axle	1	69598
7	Retaining Ring	1	PA7190
8	Spacer	2	69575
9	Roll Pin	1	PA4607
10	Thrust Bearing	1	PA2138
11	Slotted Hex Nut	1 (f)	26-28
12	Cotter Pin	1	PA2551
13	Cover	2	69600
14	Hex Head Bolt	4	35-8-32
15	Lockwasher	4	17-8C
16	Hex Nut	4	22-8
17	Drive Screw	4	PA893
18	Capacity Plate	2	(e)

NOTES:

- (a) Hook part numbers:
Acco Spring Latch Type Hook43518
Bullard Swivel Latch Type Hook with nut.....59824
- (b) Latch part numbers:
Latch for Acco Spring Latch Type HookPA5327
No latch required for Bullard Swivel Latch Type Hook
- (c) Sheave part numbers:
Polyamide sheave with bearing69573
Steel sheave with bearing.....69574
- (d) Item 4 not required.
- (e) Capacity Plate part numbers:
10 Ton - 69683-100
15 Ton - 69683-150
- (f) Item 11 included with hook for a Bullard Swivel Latch Type Hook.

No Recommended Spare Parts

**LOAD BLOCK – 2PD REEVING
1/2" ROPE DIAMETER**

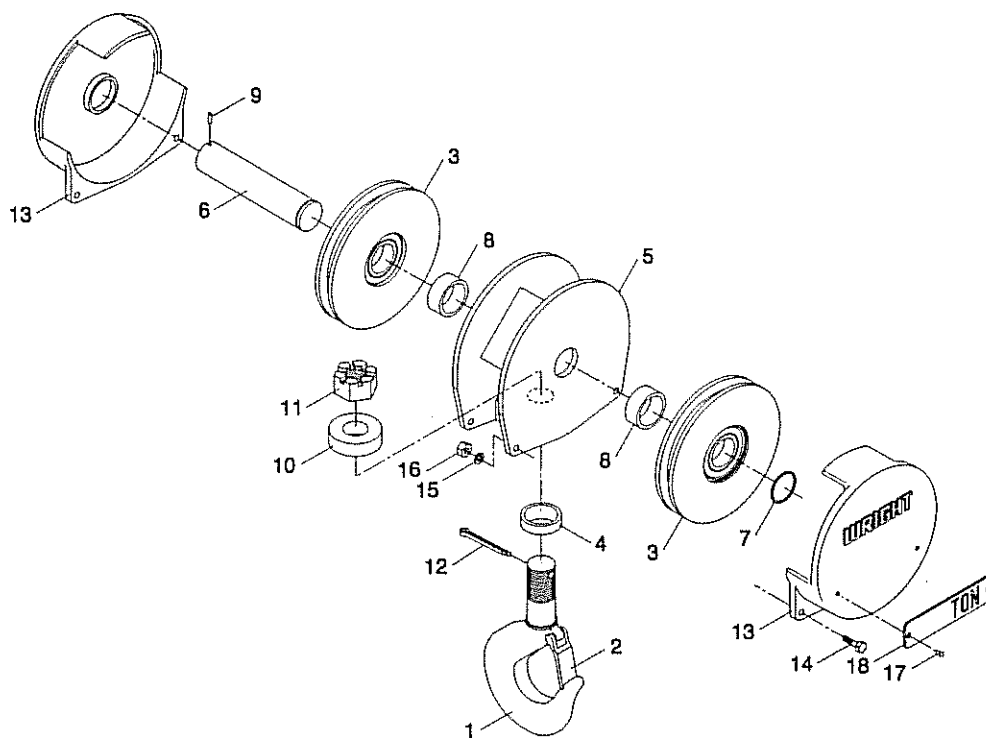

- Load Block Assembly 69555-01 – Acco Spring Latch Type Hook, Polyamide Sheave
- Load Block Assembly 69555-02 – Bullard Swivel Latch Type Hook, Polyamide Sheave
- Load Block Assembly 69555-03 – Bronze Spring Latch Type Hook, Steel Sheave
- Load Block Assembly 69555-04 – Acco Spring Latch Type Hook, Steel Sheave
- Load Block Assembly 69555-05 – Bullard Swivel Latch Type Hook, Steel Sheave
- Load Block Assembly 69555-06 – Bronze Spring Latch Type Hook, Steel Sheave

LOAD BLOCK PARTS

ITEM NO.	DESCRIPTION	QUANTITY	PART NO.
1	Hook	1	(a)
2	Latch	1	(b)
3	Sheave	2	(c)
4	Spacer	0	(d)
5	Frame	1	69591
6	Axle	1	69592
7	Retaining Ring	1	PA6941
8	Spacer	2	69569
9	Roll Pin	1	PA4607
10	Thrust Bearing	1	PA5832
11	Slotted Hex Nut	1	26-24
12	Cotter Pin	1	PA1932
13	Cover	2	69594
14	Hex Head Bolt	4	35-6-32
15	Lockwasher	4	17-6C
16	Hex Nut	4	22-6
17	Drive Screw	4	PA893
18	Capacity Plate	2	(e)

NOTES:

- (a) Hook part numbers:
 Acco Spring Latch Type Hook58012
 Bullard Swivel Latch Type Hook with nut.....58013
 Bronze Spring Latch Type Hook58014
- (b) Latch part numbers:
 Latch for Acco Spring Latch Type HookPA5327
 No latch required for Bullard Swivel Latch Type Hook
 Latch for Bronze Spring Latch Type Hook ..PA5329
- (c) Sheave part numbers:
 Polyamide sheave with bearing69567
 Steel sheave with bearing.....69568
- (d) Item 4 not required.
- (e) Capacity Plate part numbers:
 5 Ton - 69683-050
 7½ Ton - 69683-075

No Recommended Spare Parts

**LOAD BLOCK – 4PD REEVING
1/2" ROPE DIAMETER**

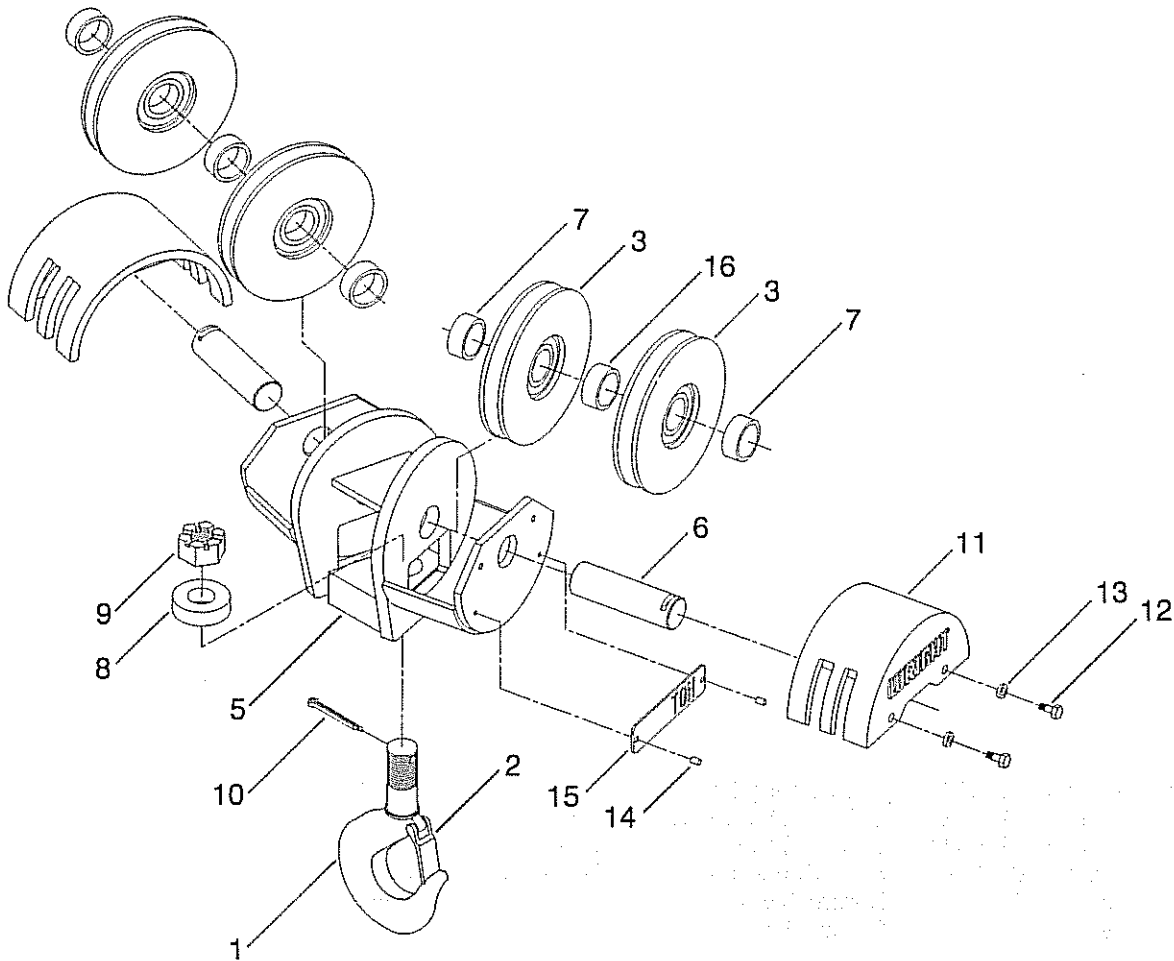

Load Block Assembly 69559-01 – Acco Spring Latch Type Hook, Polyamide Sheave
 Load Block Assembly 69559-02 – Acco Spring Latch Type Hook, Steel Sheave

LOAD BLOCK PARTS

ITEM NO.	DESCRIPTION	QUANTITY	PART NO
1	Hook	1	43577
2	Latch	1	PA5329
3	Sheave	4	(a)
4	Spacer	0	(b)
5	Frame	1	69677
6	Axle	2	69686
7	Spacer	4	69569-04
8	Thrust Bearing	1	PA1248
9	Slotted Hex Nut	1	26-32
10	Cotter Pin	1	PA3796
11	Cover	2	69673
12	Hex Head Bolt	4	35-6-12C
13	Lockwasher	4	17-6C
14	Drive Screw	4	PA893
15	Capacity Plate	2	(c)
16	Spacer	2	69569-03

NOTES:

- (a) Sheave part numbers:
 Polyamide sheave with bearing69567
 Steel sheave with bearing.....69568
- (b) Item 4 not required and not shown.
- (c) Capacity Plate part numbers:
 10 Ton - 69683-100
 15 Ton - 69683-150

No Recommended Spare Parts

GRAVITY LIMIT SWITCH

Gravity Limit Switch Assembly 70265-01 — Used on Series 32 and Series 33 2PS, 2PD, and 4PD hoists.

Gravity Limit Switch Assembly 70265-02 — Used on Series 33 4PS, Series 34, and Series 35 hoists.

GRAVITY LIMIT SWITCH PARTS

ITEM NO.	PART NO.	DESCRIPTION	QTY. 70265-01	QTY. 70265-02
1	70262	Enclosure	1	1
2	PA3598	Bushing	(a)	(a)
3	69793	Arm	1	1
4	3-08-4C	Screw	1	1
5	70264	Cam	1	1
6	3-05-14C	Screw	2	2
7	PA7400	Spring	1	1
8	3-05-2C	Screw	3	3
9	3-010-6C	Screw	1	1
10	61717	Switch Unit	1	1
11	70263	Shaft	1	1
12	64104	Insulator	1	1
13	PA3810	Spring Pin	1	1
14	PA5155	Self-tapping Screw	2	2
15	69804	Cover	1	1
16	69805	Gasket	1	1
17	PA2242	Oval Cable Sleeve	2	2
18	PA3113	Wire Rope	A.R.	A.R.
19	69827	Weight Half	2	0
20	35-4-16C	Bolt	2	0
21	22-4C	Hex Nut	2	2
22	17-4C	Lockwasher	2	2
23	19-08C	Lockwasher, Int. Tooth	1	1
24	3-010-6C	Screw	0	1
25	3-01C	Hex Nut	0	1
26	35-4-24C	Bolt	0	2
27	A2007LI	Weight Half, Left	0	1
28	A2007RI	Weight Half, Right	0	1

No Recommended Spare Parts

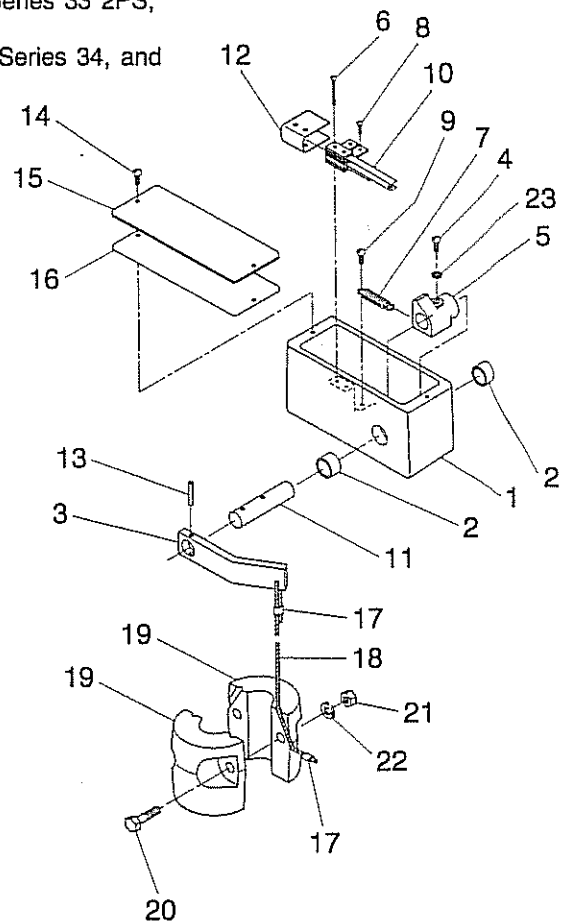

ASSEMBLY-01

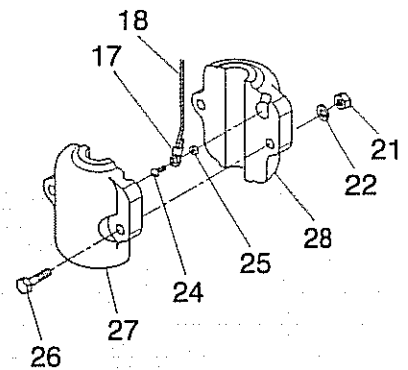

ASSEMBLY-02

NOTES:

(a) Included with Item 1.

(b) Gravity limit switch attached to hoist frame with two (2) Round Head Screws, Part No. 3-010-14C, and two (2) Locknuts, Part No. PA2423.

GEARED LIMIT SWITCH

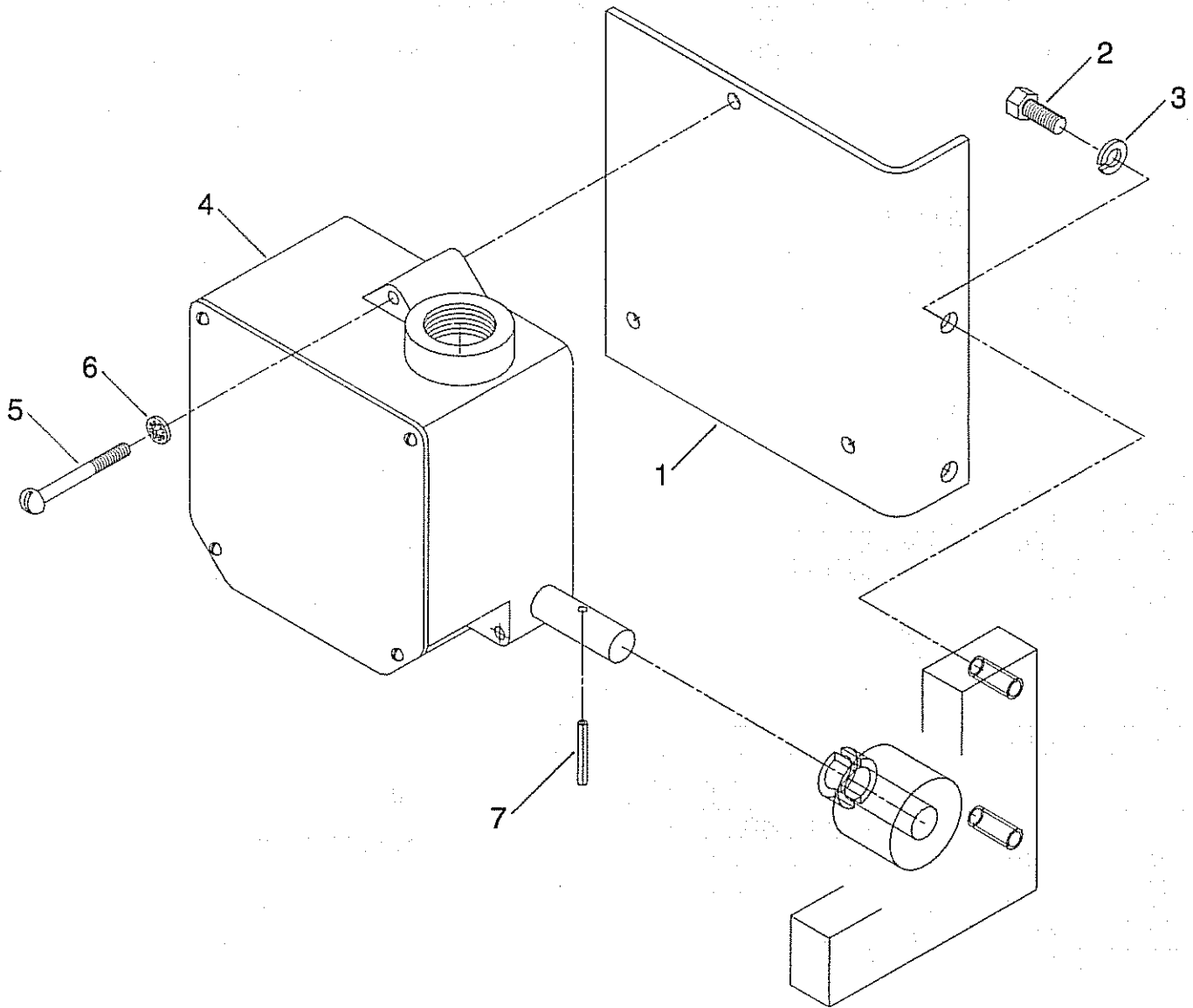

GEARED LIMIT SWITCH PARTS

ITEM NO.	PART NO.	DESCRIPTION	QTY.
1	70173	Mounting Plate	1
2	35-4-8C	Hex Head Bolt	2
3	17-4C	Lockwasher	2
4	61649-01	Geared Limit Switch 2 Circuit - 111:1 Ratio	1
4	61649-03	Geared Limit Switch 4 Circuit - 111:1 Ratio	1
4	61649-02	Geared Limit Switch 2 Circuit - 320:1 Ratio	1
4	61649-04	Geared Limit Switch 4 Circuit - 320:1 Ratio	1
5	3-010-24C	Round Head Screw	3
6	19-010C	Lockwasher	3
7	PA3810	Drive Pin	1

No Recommended Spare Parts

HOIST RECTIFIED D.C. BRAKE CONTROL

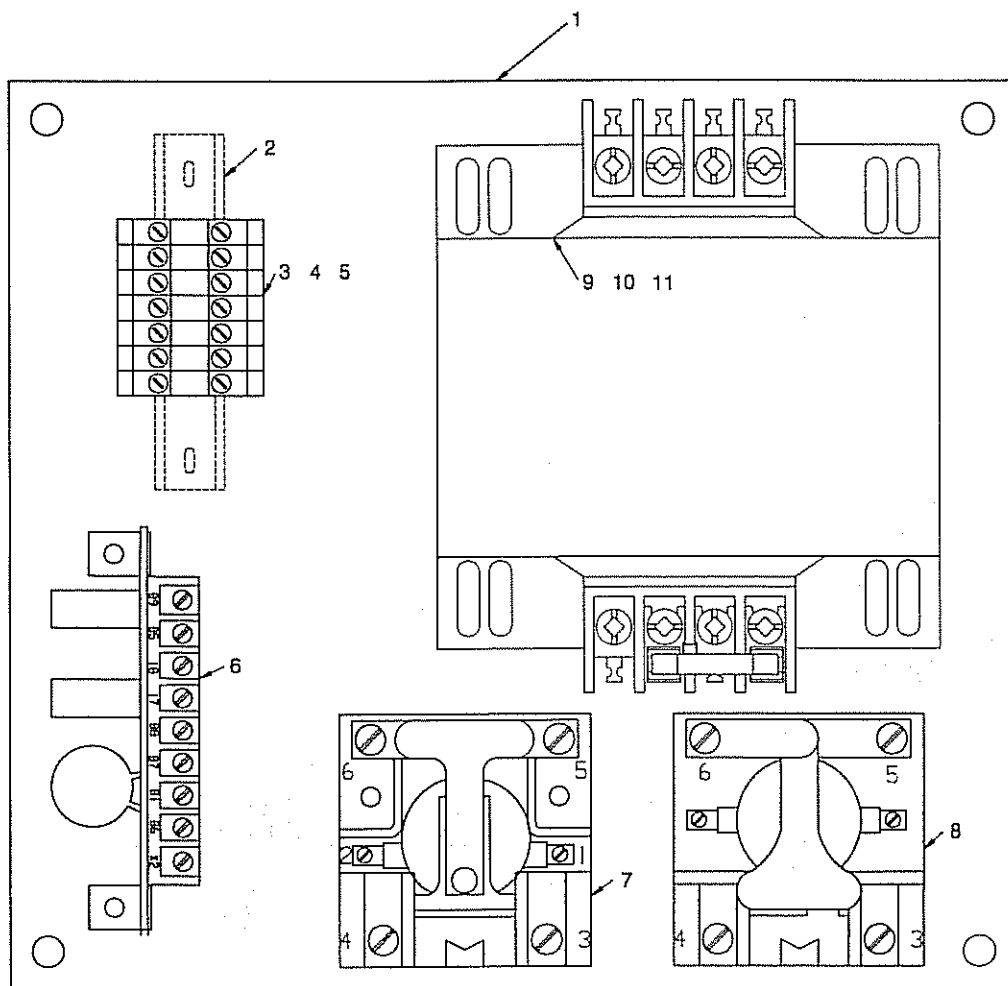

REPLACEMENT PARTS

ITEM NO.	PART NUMBER	DESCRIPTION
1	86828	Panel, Drilled
2	86714-12	Din Rail, Pre-cut, 3-1/2" L.
3	86710-05	Terminal, End Anchor
4	86710-07	Terminal, End Barrier
5	86710-01	Terminal, Control
6▲	86712	Brake Circuit Control Board
7▲	PA6496	Relay, Brake Ctrl. (BC) for 115V. Control
	PA6373	Relay, Brake Ctrl. (BC) for 24V. Control

ITEM NO.	PART NUMBER	DESCRIPTION
8▲	PA6254	Relay, Brake (BR) for 115V. Control
	PA6255	Relay, Brake (BR) for 24V. Control
9	52429-80	Transformer Fuse Holder
10▲	PA6334	Transformer Fuse (350VA)
	PA6335	Transformer Fuse (500VA)
11	52429-09	Transformer, 350VA, 200-115
	52429-21	Transformer, 350VA, 230/460-115
	52429-44	Transformer, 350VA, 575-115
	52429-10	Transformer, 500VA, 200-115
	52429-22	Transformer, 500VA, 230/460-115
	52429-45	Transformer, 500VA, 575-115

▲ Recommended Spare Parts

BASIC CONTROL COMPONENTS

SINGLE OR TWO SPEED HOIST, LUG MTD., PLAIN OR GEARED TROLLEY OR SINGLE SPEED HOIST SINGLE SPEED TROLLEY COMBINATION

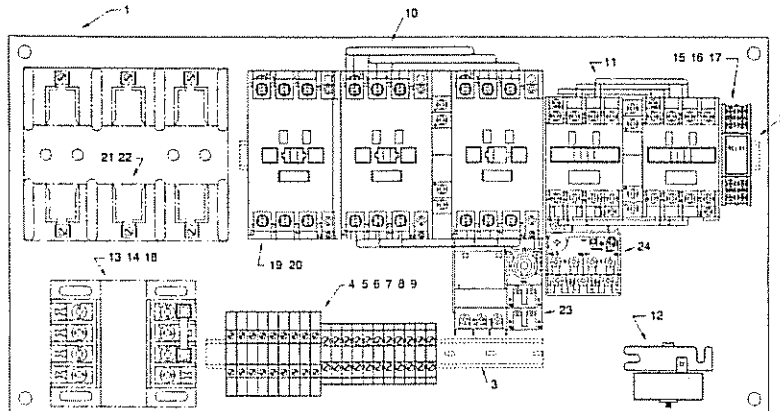

REPLACEMENT PARTS

ITEM NO.	PART NUMBER	DESCRIPTION
1	86822	Panel, Drilled
2	86714-06	DIN Rail, Pre-cut, 12"
3	86714-02	DIN Rail, Pre-cut, 8"
4	86710-04	Terminal, Grounding
5	86710-05	Terminal, End Anchor
6	86710-06	Terminal, End Barrier, Power
7	86710-07	Terminal, End Barrier, Control
8	86710-01	Terminal, Control
9	86710-02	Terminal, Power
10▲	86702-01	Contact, Reversing, (or Two Speed) 115 V (Hoist) Size C, For Two Speed Contactor remove load side jumper wires (black wires)
	86702-02	Contact, Reversing, (or Two Speed) 24 V (Hoist) Size C, For Two Speed Contactor remove load side jumper wires (black wires)
	86703-01	Contact, Reversing (or Two Speed) 115 V (Hoist) Size D, For Two Speed Contactor remove load side jumper wires (black wires)
	86703-02	Contact, Reversing (or Two Speed) 24 V (Hoist) Size D, For Two Speed Contactor remove load side jumper wires (black wires)
11▲	86701-01	Contact, Reversing (or Two Speed) 115 V (Trolley) Size B, For Two Speed Contactor remove load side jumper wires (black wires)
	86701-02	Contact, Reversing (or Two Speed) 115 V (Trolley) Size B, For Two Speed Contactor remove load side jumper wires (black wires)
12	PA7103	Time Capsule, 115 V (Two Speed Only)
	PA7104	Time Capsule, 24 V (Two Speed Only)

ITEM NO.	PART NUMBER	DESCRIPTION
13	52429-80	Transformer Fuse Clip (24 V controls only)
14▲	PA7330	Transformer Fuse (24 V controls only) 50 VA
	PA6334	Transformer Fuse (24 V controls only) 75 VA
15▲	PA7382	Relay, Control, 115 V (Two Speed Only)
	PA7383	Relay, Control, 24 V (Two Speed Only)
16	PA7384	Relay, Socket
17	PA7385	Relay, Retainer Clip
18	52429-XX	Transformer (24 V controls only) -52 for 200 V; -26 for 230/460 V; -64 for 575 V Supply (50 VA)
	52429-XX	Transformer (24 V controls only) -53 for 200 V; -27 for 230/460 V; -65 for 575 V Supply (75 VA)
19	86704-01	Mainline Contactor, 115 V Size C (Optional)
	86704-02	Mainline Contactor, 24 V Size C (Optional)
	86705-01	Mainline Contractor, 115 V Size D (Optional)
	86705-02	Mainline Contactor, 24 V Size D (Optional)
20	86708-02	Contact Block, Aux. (used with Mainline Contactor)
21	PA7341	Fuse Block, Mtr. Ckt. 30A. (Optional)
	PA7342	Fuse Block, Mtr. Ckt. 60A. (Optional)
22▲	86709-XX	Fuse, Mtr. Ckt. (Optional) see note below
23	86706-XX	Overload Relay, Hoist (Optional) see note below
24	86706-XX	Overload Relay, Trolley (Optional) see note below
Not Shown	69505-02	Danger Label, Electrical

▲ Recommended Spare Parts

NOTE:

When ordering Motor Circuit Fuses or Overload Relays, provide as much information about the hoist as possible. Hoist serial number, motor H.P's., full load currents, supply voltage, etc.

BASIC CONTROL COMPONENTS

SINGLE OR TWO SPEED HOIST AND TROLLEY CONTROL WITH ACM & SIZE "C" HOIST CONTACTOR

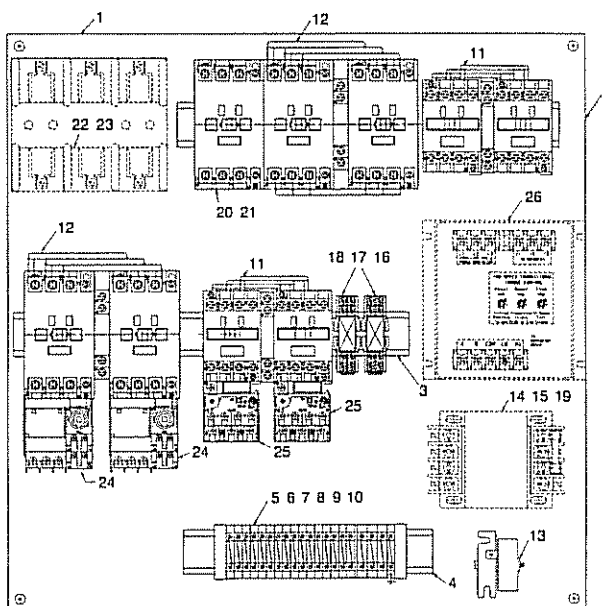

REPLACEMENT PARTS

ITEM NO.	PART NUMBER	DESCRIPTION
1	86824	Panel, Drilled
2	86714-11	DIN Rail, Pre-cut, 13" L.
3	86714-10	DIN Rail, Pre-cut, 12.5" L.
4	86714-02	DIN Rail, Pre-Cut, 8" L.
5	86710-04	Terminal, Grounding
6	86710-05	Terminal, End Anchor
7	86710-06	Terminal, End Barrier, Power
8	86710-07	Terminal, End Barrier, Control
9	86710-01	Terminal, Control
10	86710-02	Terminal, Power
11▲	86701-01	Contact, Reversing, (or Two Speed) 115 V (Trolley) Size B, For Two Speed Contacter remove load side jumper wires (black wires)
	86701-02	Contact, Reversing, (or Two Speed) 24 V (Trolley) Size B, For Two Speed Contacter remove load side jumper wires (black wires)
12▲	86702-01	Contact, Reversing, (or Two Speed) 115 V (Hoist) Size C, For Two Speed Contacter remove load side jumper wires (black wires)
	86702-02	Contact, Reversing, (or Two Speed) 24 V (Hoist) Size C, For Two Speed Contacter remove load side jumper wires (black wires)
13	PA7103	Time Capsule, 115 V (Two Speed Only)
	PA7104	Time Capsule, 24 V (Two Speed Only)
14	52429-80	Transformer Fuse Clip (24 V Models Only)
15▲	PA7330	Transformer Fuse (24 V Models Only)

ITEM NO.	PART NUMBER	DESCRIPTION
16	PA7382	Relay, Control, 115 V (Two Speed Only)
	PA7383	Relay, Control, 24 V (Two Speed Only)
17	PA7384	Relay, Socket (Two Speed Only)
18	PA7385	Relay, Hold Down Clip
19	52429-XX	Transformer (24 V controls only) -52 for 200 V; -26 for 230/460 V; -64 for 575 V Supply (50 VA)
20	86704-01	Mainline Contactor, 115 V Size C (Optional)
	86704-02	Mainline Contactor, 24 V Size C (Optional)
21	86708-02	Contact Block, Aux. (used with Mainline Contactor)
22	PA7341	Fuse Block, Motor Ckt. 30A. (Optional)
	PA7342	Fuse Block, Motor Ckt. 60A. (Optional)
23▲	86709-XX	Fuse, Motor Circuit (Optional) see note below
24	86706-XX	Overload Relay, Hoist (Optional) see note below
25	86706-XX	Overload Relay, Trolley (Optional) see note below
26	86715-017	ACM, S.S. 1 H.P. 200-230 V 2 H.P. Max. 460 V
	86715-019	ACM, S.S. 2.5 H.P. 200-230 V 5 H.P. Max. 460 V
	86715-018	ACM, 2S. 1 H.P. 200-230 V 2 H.P. Max. 460 V
	86715-020	ACM, 2S. 2.5 H.P. 200-230 V 5 H.P. Max. 460 V
	86715-002	ACM, S.S. 2 H.P. Max. 575 V
	86715-004	ACM, S.S. 5 H.P. Max. 575 V
	86715-006	ACM, 2S. 2 H.P. Max. 575 V
86715-008	ACM, 2S. 5 H.P. Max. 575 V	
Not Shown	69505-02	Danger Label, Electrical

▲ Recommended Spare Parts

NOTE:

When ordering Motor Circuit Fuses or Overload Relays, provide as much information about the hoist as possible. Hoist serial number, motor H.P.'s., full load currents, supply voltage, etc. ACM's listed are for 115 V control only. For 24 V control, order by description.

BASIC CONTROL COMPONENTS

SINGLE OR TWO SPEED HOIST AND TROLLEY CONTROL WITH SIZE "D" HOIST CONTACTOR

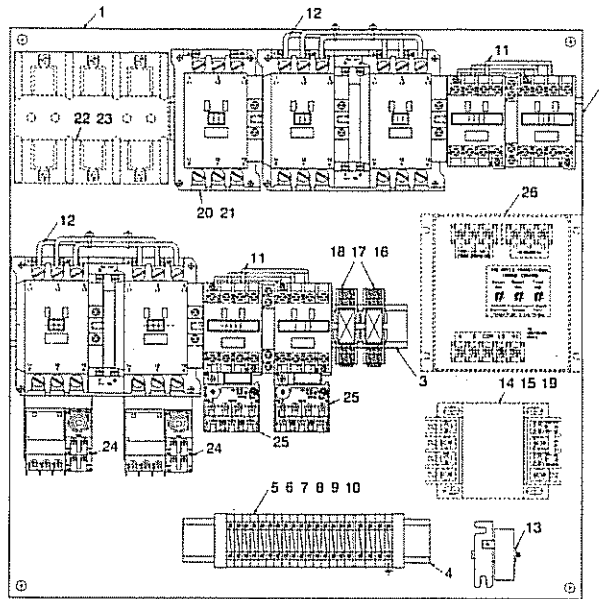

REPLACEMENT PARTS

ITEM NO.	PART NUMBER	DESCRIPTION
1	86824	Panel, Drilled
2	86714-11	DIN Rail, Pre-cut, 13" L.
3	86714-10	DIN Rail, Pre-cut, 12.5" L.
4	86714-02	DIN Rail, Pre-Cut, 8" L.
5	86710-04	Terminal, Grounding
6	86710-05	Terminal, End Anchor
7	86710-06	Terminal, End Barrier, Power
8	86710-07	Terminal, End Barrier, Control
9	86710-01	Terminal, Control
10	86710-02	Terminal, Power
11▲	86701-01	Contactor, Reversing, (or Two Speed) 115 V (Trolley) Size B, For Two Speed Contactor remove load side jumper wires (black wires)
	86701-02	Contactor, Reversing, (or Two Speed) 24 V (Trolley) Size B, For Two Speed Contactor remove load side jumper wires (black wires)
12▲	86703-01	Contactor, Reversing, (or Two Speed) 115 V (Hoist) Size D, For Two Speed Contactor remove load side jumper wires (black wires)
	86703-02	Contactor, Reversing, (or Two Speed) 24 V (Hoist) Size D, For Two Speed Contactor remove load side jumper wires (black wires)
13	PA7103	Time Capsule, 115 V (Two Speed Only)
	PA7104	Time Capsule, 24 V (Two Speed Only)
14	52429-80	Transformer Fuse Clip (24 V Models Only)
15▲	PA6335	Transformer Fuse (24 V Models Only)

ITEM NO.	PART NUMBER	DESCRIPTION
16	PA7382	Relay, Control, 115 V (Two Speed Only)
	PA7383	Relay, Control, 24 V (Two Speed Only)
17	PA7384	Relay, Socket (Two Speed Only)
18	PA7385	Relay, Hold Down Clip
19	52429-XX	Transformer (24 V controls only) -54 for 200 V; -28 for 230/460 V; -66 for 575 Supply (100 VA)
20	86705-01	Mainline Contactor, 115 V Size D (Optional)
	86705-02	Mainline Contactor, 24 V Size D (Optional)
21	86708-02	Contact Block, Aux. (used with Mainline Contactor)
22	PA7341	Fuse Block, Motor Ckt., 30A. (Optional)
	PA7342	Fuse, Motor Ckt., 60A. (Optional)
23▲	86709-XX	Fuse, Motor Circuit (Optional) see note below
24	86706-XX	Overload Relay, Hoist (Optional) see note below
25	86706-XX	Overload Relay, Trolley (Optional) see not below
26	86715-017	ACM, S.S. 1 H.P. 200-230 V 2 H.P. 460 V
	86715-019	ACM, S.S. 2.5 H.P. 200-230 V 5 H.P. 460 V
	86715-018	ACM, 2S. 1 H.P. 200-230 V 2 H.P. 460 V
	86715-020	ACM, 2S. 2.5 H.P. 200-230 V 5 H.P. 460 V
	86715-002	ACM, S.S. 2 H.P. 575 V
	86715-004	ACM, S.S. 5 H.P. 575 V
	86715-006	ACM, 2S. 2 H.P. 575 V
86715-008	ACM, 2S. 5 H.P. 575 V	
Not Shown	69505-02	Danger Label, Electrical

▲ Recommended Spare Parts

NOTE:

When ordering Motor Circuit Fuses or Overload Relays, provide as much information about the hoist as possible. Hoist serial number, motor H.P.'s., full load currents, supply voltage, etc. ACM's listed are for 115 V cntrl. only, for 24 V order by description.

PENDANT CONTROL STATION

PENDANT CONTROL STATION PARTS LIST

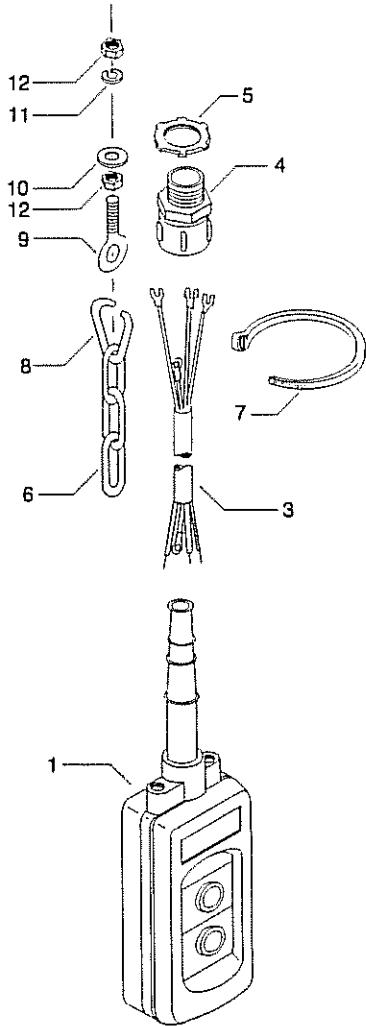

PUSHBUTTON STATION

ITEM NO.	PART NUMBER	DESCRIPTION
1	68898-01	2-Button, Single Speed Pushbutton Station Assembly
	68898-02	2-Button, Two Speed Pushbutton Station Assembly
	86718-02	4-Button, Pushbutton Station, Enclosure only
	86718-03	6-Button, Pushbutton Station Enclosure only
	86718-04	8-Button, Pushbutton Station Enclosure only
2	86718-16	Single Speed Contact Block (not shown)
	86718-19	Two Speed Contact Block (not shown)
	86718-05	Operator Button (Black)
	86718-06	Operator Button (Green)
	86718-07	Operator Button (Red)
3	62046	Cable, 16 Awg., 4 Cond.
	PA2513	Cable, 16 Awg., 8 Cond.
	PA2514	Cable, 16 Awg., 14 Cond.
4	PA2427	Cable Grip, 4 Cond. Cable
	PA2145	Cable Grip, 8 Cond. Cable
	PA2517	Cable Grip, 14 Cond. Cable
5	PA1827	Locknut for PA2427 & PA2145
	PA2036	Locknut for PA2517
6	PA2034	Strain Relief Chain
7	PA6750	Self Locking Tie
8	PA2035	Chain Repair Link
9	PA5037	Eye Bolt
10	15-4-2C	Washer
11	17-4C	Lockwasher
12	22-4C	Nut
13	63178-01	Warning Label

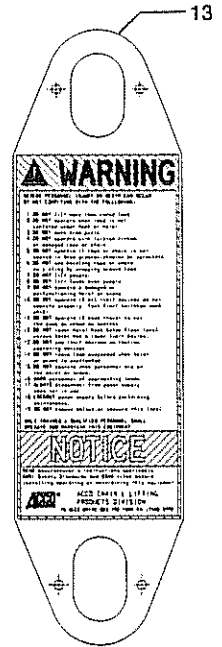

WARNING LABEL
63178-01
Replace Label
If Lost or Illegible

NOTE:

When ordering pushbutton control cable or strain relief chain, specify length in feet. When specifying length of control cable, allow sufficient length to make connections inside of pushbutton station and control enclosure.

PENDANT CONTROL STATION

PENDANT CONTROL STATION PARTS LIST

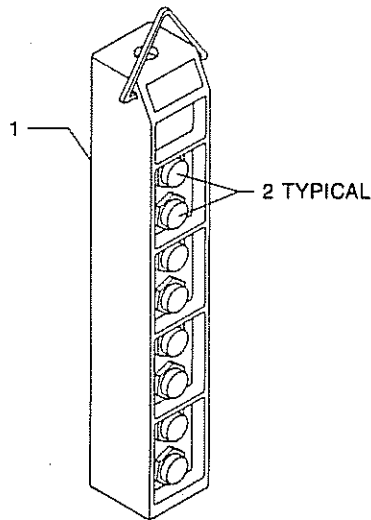
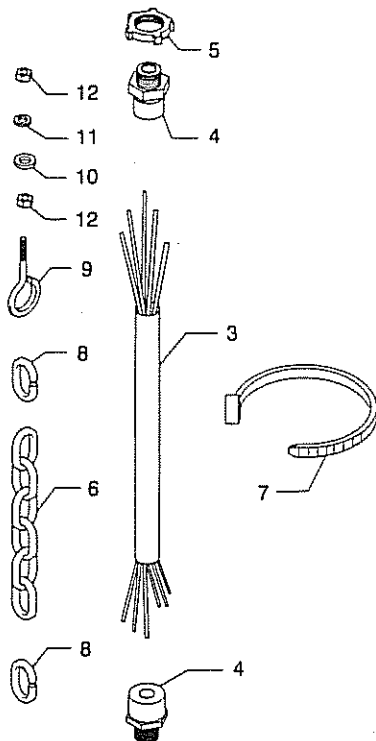

PUSHBUTTON STATION

ITEM NO.	PART NUMBER	DESCRIPTION
1	86716-01	2-Button Enclosure
	86716-02	4-Button Enclosure
	86716-03	6-Button Enclosure
	86716-04	8-Button Enclosure
	86716-05	10-Button Enclosure
2	86716-06	Single Speed Button Assy.
	86716-07	Two Speed Button Assy.
	86716-08	Three Speed Button Assy.
	86716-09	Five Speed Button Assy.
	86716-10	On Button (Green)
	86716-11	Off Button (Red)
	86716-12	Pilot Light (Red)
	86716-13	Two Position Maint. Selector Switch
	86716-14	Three Position Maint. Selector Switch
	86716-15	Push - Pull Operator (Maint.)
	86716-16	Red Mushroom Head Operator (Momentary)
86716-17	Two Position Keylock Selector (Maint.)	
86716-18	2-Button Maint. Operator (Interlocked)	
86716-19	Contact Block (1 N.O. & 1 N.C.)	
86716-20	Closing Button (For Unused Holes)	
86716-21	P.B. Operator (Black, 1 N.O. & 1 N.C.)	
3	62046	Cable, 16 AWG., 4 Cond.
	PA2513	Cable, 16 AWG. 8 Cond.
	PA2514	Cable, 16 AWG., 14 Cond.
	PA6706	Cable, 16 AWG., 24 Cond.
4	PA2427	Cable Grip, 4 Cond. Cable
	PA6652	Cable Grip, 8 Cond. Cable
	PA2517	Cable Grip, 14 Cond. Cable
	PA6705	Cable Grip, 24 Cond. Cable
5	PA1827	Locknut for PA2427 & PA6652
	PA2036	Locknut for PA2517
	PA1828	Locknut for PA6705
6	PA2034	Strain Relief Chain
7	PA6750	Self Locking Tie
8	PA2035	Chain Repair Link
9	PA5037	Eye Bolt
10	15-4-2C	Washer
11	17-4C	Lockwasher
12	22-4C	Nut
13	63178-01	Warning Label

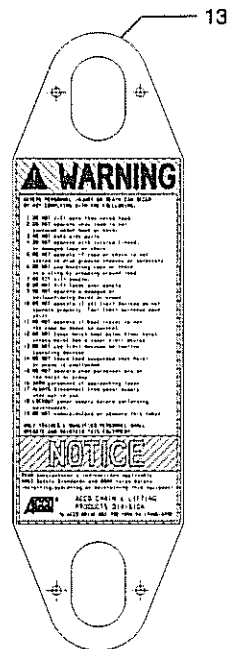

WARNING LABEL
63178-01
Replace Label
If Lost or Illegible

NOTE: When ordering pushbutton control cable or strain relief chain, specify length in feet. When specifying length of control cable, allow sufficient length to make connections inside of pushbutton station and control enclosure.

**2-WHEEL PLAIN TROLLEY ASSEMBLY
6 IN. DIAMETER WHEEL
NON-SWIVELING – TWO MOUNTING STUDS**

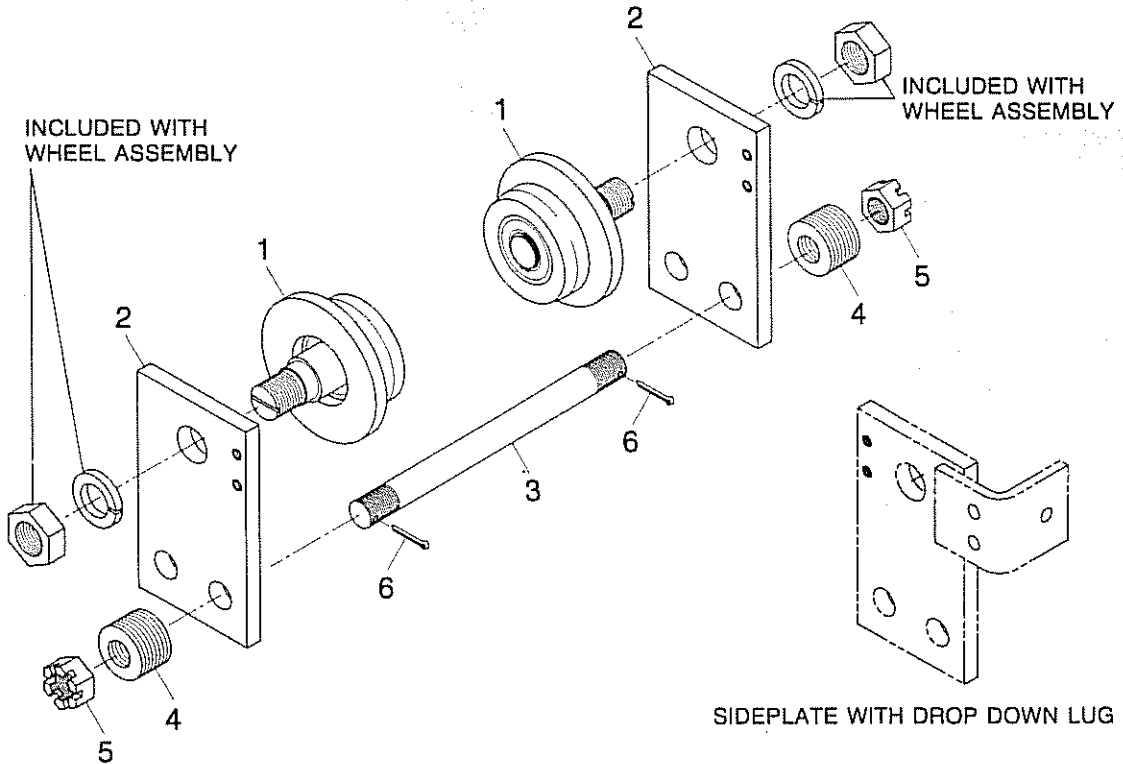

TROLLEY PARTS – 6" DIAMETER WHEELS

TROLLEY ASSEMBLY	BEAM FLANGE WIDTH (Inches)	DROP DOWN LUGS	WHEEL ASSEMBLY		SIDEPLATE	SIDEPLATE	STUD	WASHER		NUT	COTTER PIN
			2 PER TROLLEY		1 PER TROLLEY	1 PER TROLLEY	2 PER TROLLEY			4 PER TROLLEY	4 PER TROLLEY
			MATL.	ITEM 1	ITEM 2	ITEM 2	ITEM 3	QTY/TRLY	ITEM 4	ITEM 5	ITEM 6
69988-01	4-1/2 to 5	No	Steel Dual Tread	69974-01	69986-01	69986-01	69766-04	36	A210-03	26-20	PA1355
69988-02	5-1/8 to 8				69986-01	69986-01	69766-05	76			
69988-03	8-1/8 to 10-1/2				69987-01	69987-01	69766-06	40			
69988-04	4-1/2 to 5		Bronze Dual Tread	69974-02	69986-01	69986-01	69766-04	36			
69988-05	5-1/8 to 8				69986-01	69986-01	69766-05	76			
69988-06	8-1/8 to 10-1/2				69987-01	69987-01	69766-06	40			
69988-07	4-1/2 to 5	Yes	Steel Dual Tread	69974-01	69986-02	69986-03	69766-04	36			
69988-08	5-1/8 to 8				69986-02	69986-03	69766-05	76			
69988-09	8-1/8 to 10-1/2				69987-02	69987-03	69766-06	40			
69988-10	4-1/2 to 5		Bronze Dual Tread	69974-02	69986-02	69986-03	69766-04	36			
69988-11	5-1/8 to 8				69986-02	69986-03	69766-05	76			
69988-12	8-1/8 to 10-1/2				69987-02	69987-03	69766-06	40			
69988-13	3-1/4 to 5 (a)	No	Steel Flat	69976-01	69986-01	69986-01	69766-04	36			
69988-14	3-1/4 to 5 (a)		Bronze Flat	69976-02							
69988-15	3-1/4 to 5 (a)	Yes	Steel Flat	69976-01	69986-02	69986-03					
69988-16	3-1/4 to 5 (a)		Bronze Flat	69976-02							

No Recommended Spare Parts

NOTE:

(a) For operation on patented monorail track.

**4-WHEEL PLAIN TROLLEY ASSEMBLY
6 IN. DIAMETER WHEEL
NON-SWIVELING – ONE MOUNTING STUD**

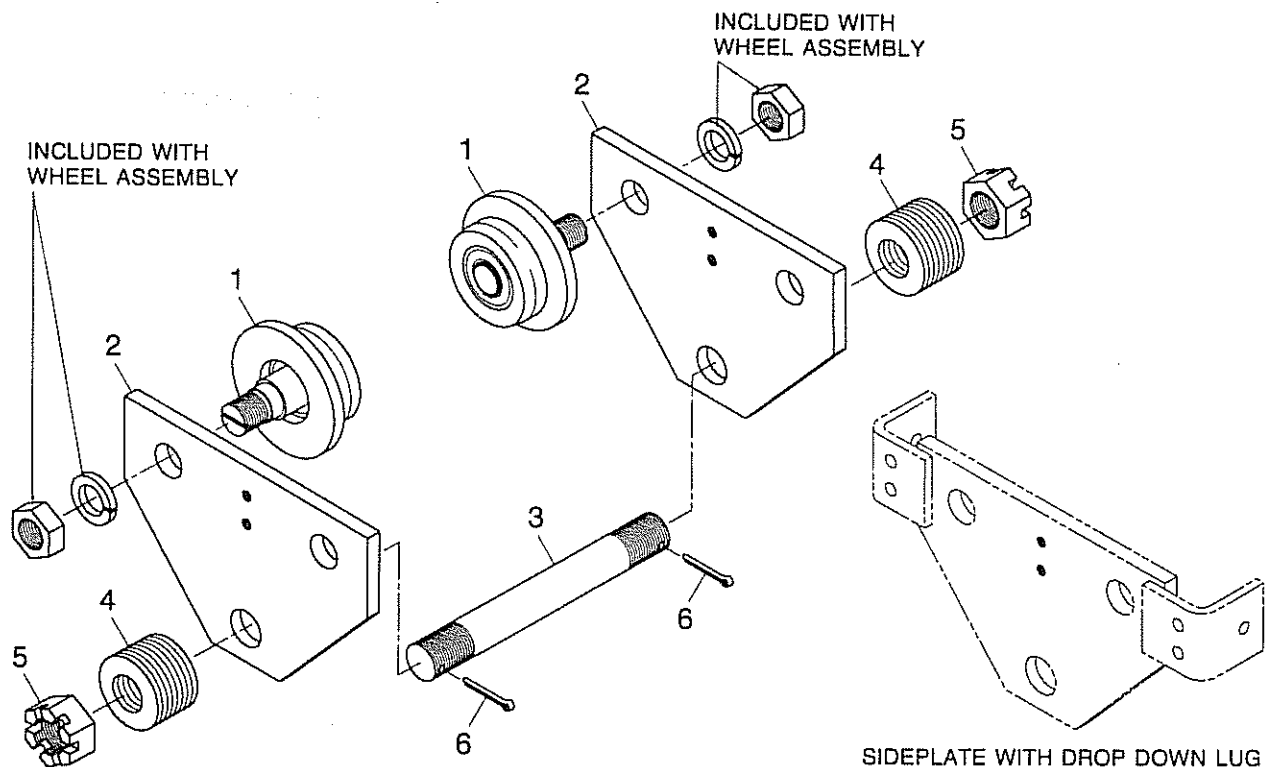

TROLLEY PARTS – 6" DIAMETER WHEELS

TROLLEY ASSEMBLY	BEAM FLANGE WIDTH (Inches)	DROP DOWN LUGS	WHEEL ASSEMBLY		SIDEPLATE	STUD	WASHER		NUT	COTTER PIN		
			4 PER TROLLEY		2 PER TROLLEY	1 PER TROLLEY			2 PER TROLLEY	2 PER TROLLEY		
			MATL.	ITEM 1	ITEM 2	ITEM 3	QTY/TRLY	ITEM 4	ITEM 5	ITEM 6		
69993-01	4-1/2 to 5	No	Steel Dual Tread	69974-01	69979-01	69768-04	PA5167	26-32	PA3796			
69993-02	5-1/8 to 8				69980-01	69768-05				18		
69993-03	8-1/8 to 10-1/2				69981-01	69768-06				20		
69993-04	4-1/2 to 5		Bronze Dual Tread	69974-02	69979-01	69768-04				16		
69993-05	5-1/8 to 8				69980-01	69768-05				18		
69993-06	8-1/8 to 10-1/2				69981-01	69768-06				20		
69993-07	4-1/2 to 5	Yes	Steel Dual Tread	69974-01	69979-02	69768-04	PA5167	26-32	PA3796			
69993-08	5-1/8 to 8				69980-02	69768-05				18		
69993-09	8-1/8 to 10-1/2				69981-02	69768-06				20		
69993-10	4-1/2 to 5		Bronze Dual Tread	69974-02	69979-02	69768-04				16		
69993-11	5-1/8 to 8				69980-02	69768-05				18		
69993-12	8-1/8 to 10-1/2				69981-02	69768-06				20		
69993-13	3-1/4 to 5 (a)	No	Steel Flat	69976-01	69979-01	69768-04	16					
69993-14	3-1/4 to 5 (a)		Bronze Flat	69976-02								
69993-15	3-1/4 to 5 (a)	Yes	Steel Flat	69976-01	69979-02					16		
69993-16	3-1/4 to 5 (a)		Bronze Flat	69976-02								

No Recommended Spare Parts

NOTE:

(a) For operation on patented monorail track.

**4-WHEEL GEARED TROLLEY ASSEMBLY
6 IN. DIAMETER WHEEL
NON-SWIVELING – ONE MOUNTING STUD**

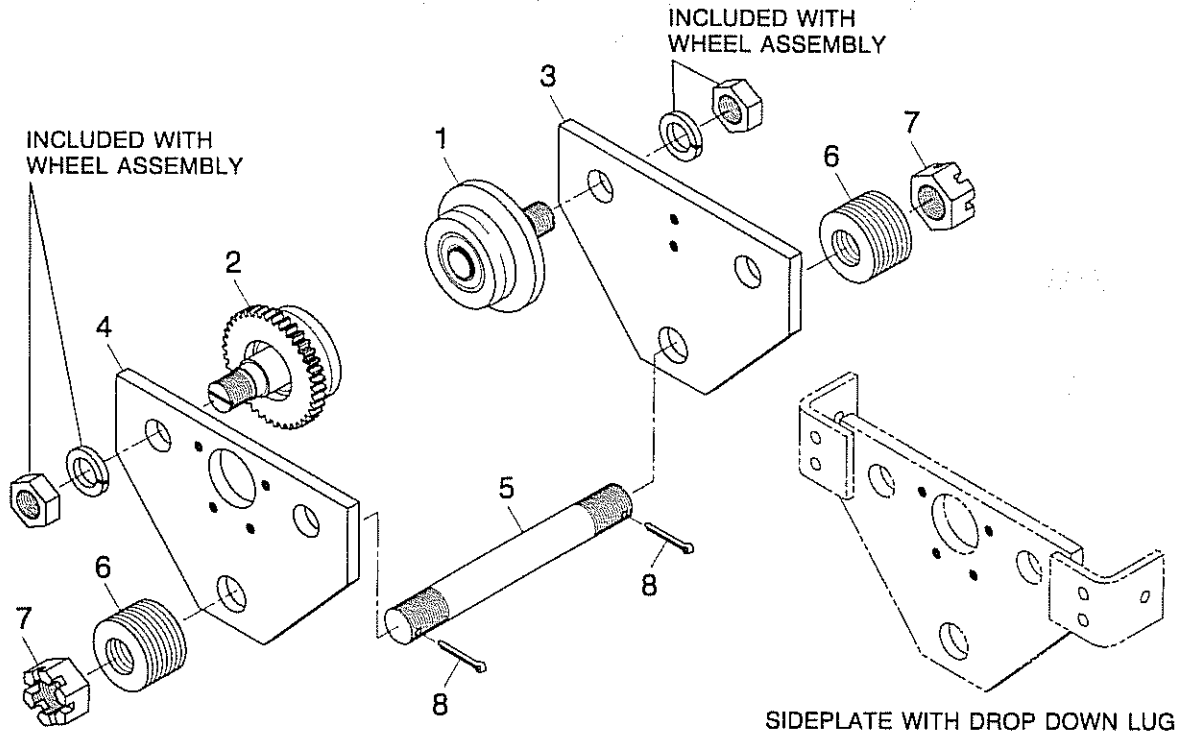

TROLLEY PARTS – 6" DIAMETER WHEELS

TROLLEY ASSEMBLY	BEAM FLANGE WIDTH (Inches)	DROP DOWN LUGS	WHEEL ASSEMBLY			SIDEPLATE	SIDEPLATE	STUD	WASHER		NUT	COTTER PIN
			2 EACH PER TROLLEY			1 PER TROLLEY	1 PER TROLLEY	1 PER TROLLEY			2 PER TROLLEY	2 PER TROLLEY
			MATL.	PLAIN ITEM 1	GEARED ITEM 2	ITEM 3	ITEM 4	ITEM 5	QTY/ TRLY	ITEM 6	ITEM 7	ITEM 8
69994-01	4-1/2 to 5	No	Steel Dual Tread	69974-01	69975-01	69979-01	69982-01	69768-04	16	PA5167	26-32	PA3796
69994-02	5-1/8 to 8					69980-01	69983-01	69768-05	18			
69994-03	8-1/8 to 10-1/2					69981-01	69984-01	69768-06	20			
69994-04	4-1/2 to 5		Bronze Dual Tread	69974-02	69975-02	69979-01	69982-01	69768-04	16			
69994-05	5-1/8 to 8					69980-01	69983-01	69768-05	18			
69994-06	8-1/8 to 10-1/2					69981-01	69984-01	69768-06	20			
69994-07	4-1/2 to 5	Yes	Steel Dual Tread	69974-01	69975-01	69979-02	69982-02	69768-04	16			
69994-08	5-1/8 to 8					69980-02	69983-02	69768-05	18			
69994-09	8-1/8 to 10-1/2					69981-02	69984-02	69768-06	20			
69994-10	4-1/2 to 5		Bronze Dual Tread	69974-02	69975-02	69979-02	69982-02	69768-04	16			
69994-11	5-1/8 to 8					69980-02	69983-02	69768-05	18			
69994-12	8-1/8 to 10-1/2					69981-02	69984-02	69768-06	20			
69994-13	3-1/4 to 5 (a)	No	Steel Flat	69976-01	69977-01	69979-01	69982-01	69768-04	16			
69994-14	3-1/4 to 5 (a)		Bronze Flat	69976-02	69977-02							
69994-15	3-1/4 to 5 (a)	Yes	Steel Flat	69976-01	69977-01	69979-02	69982-02	69768-04	16			
69994-16	3-1/4 to 5 (a)		Bronze Flat	69976-02	69977-02							

No Recommended Spare Parts

NOTE:

(a) For operation on patented monorail track.

**4-WHEEL GEARED TROLLEY ASSEMBLY
DUAL DRIVE
6 IN. DIAMETER WHEEL
NON-SWIVELING – ONE MOUNTING STUD**

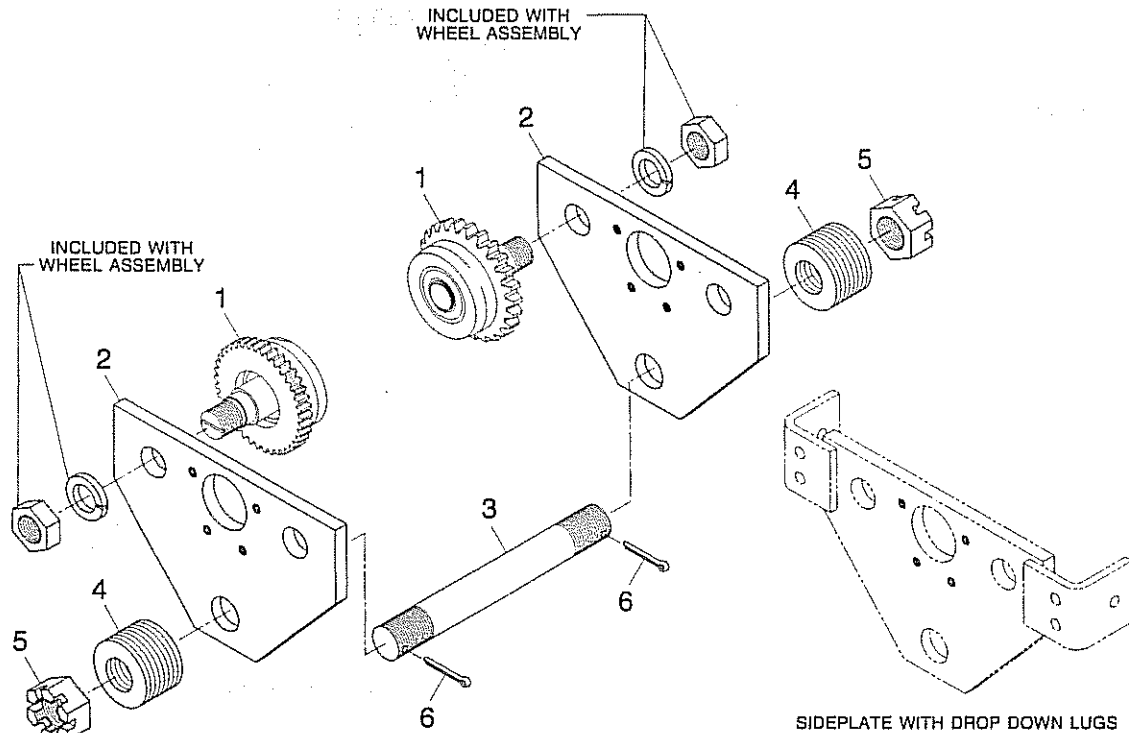

TROLLEY PARTS – 6" DIAMETER WHEELS

TROLLEY ASSEMBLY	BEAM FLANGE WIDTH (Inches)	DROP DOWN LUGS	WHEEL ASSEMBLY		SIDEPLATE	STUD	WASHER		NUT	COTTER PIN
			4 PER TROLLEY		2 PER TROLLEY	1 PER TROLLEY			2 PER TROLLEY	2 PER TROLLEY
			MATL.	ITEM 1	ITEM 2	ITEM 3	QTY/TRLY	ITEM 4	ITEM 5	ITEM 6
69997-01	4-1/2 to 5	No	Steel Dual Tread	69975-01	69982-01	69768-04	16	PA5167	26-32	PA3796
69997-02	5-1/8 to 8				69983-01	69768-05	18			
69997-03	8-1/8 to 10-1/2				69984-01	69768-06	20			
69997-04	4-1/2 to 5		Bronze Dual Tread	69975-02	69982-01	69768-04	16			
69997-05	5-1/8 to 8				69983-01	69768-05	18			
69997-06	8-1/8 to 10-1/2				69984-01	69768-06	20			
69997-07	4-1/2 to 5	Yes	Steel Dual Tread	69975-01	69982-02	69768-04	16			
69997-08	5-1/8 to 8				69983-02	69768-05	18			
69997-09	8-1/8 to 10-1/2				69984-02	69768-06	20			
69997-10	4-1/2 to 5		Bronze Dual Tread	69975-02	69982-01	69768-04	16			
69997-11	5-1/8 to 8				69983-02	69768-05	18			
69997-12	8-1/8 to 10-1/2				69984-02	69768-06	20			
69997-13	3-1/4 to 5 (a)	No	Steel Flat	69977-01	69982-01	69768-04	16			
69997-14	3-1/4 to 5 (a)		Bronze Flat	69977-02						
69997-15	3-1/4 to 5 (a)	Yes	Steel Flat	69977-01	69982-02					
69997-16	3-1/4 to 5 (a)		Bronze Flat	69977-02						

No Recommended Spare Parts

NOTE:

(a) For operation on patented monorail track.

LOADBAR ASSEMBLY — FOR RIGID TROLLEYS

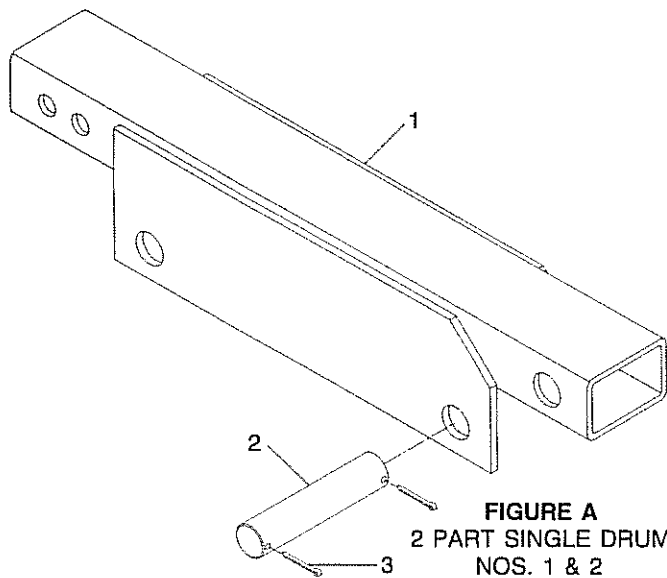

FIGURE A
2 PART SINGLE DRUM
NOS. 1 & 2

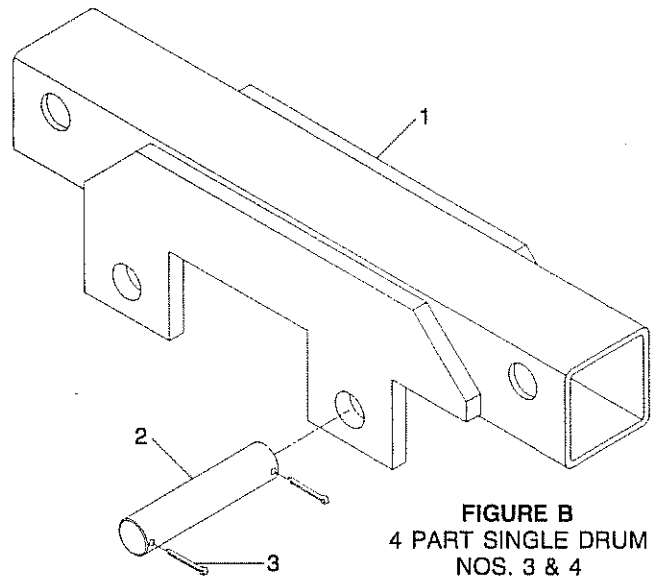

FIGURE B
4 PART SINGLE DRUM
NOS. 3 & 4

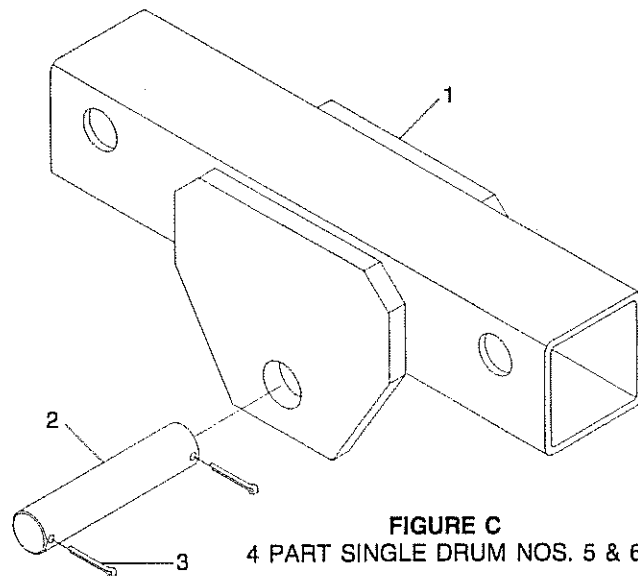

FIGURE C
4 PART SINGLE DRUM NOS. 5 & 6

LOADBAR PARTS

ITEM NO.	PART NO.	DESCRIPTION	QTY.
1	70219-01	Loadbar, 2PS, Drum No. 1	1
	70219-02	Loadbar, 2PS, Drum No. 2	
	70168-03	Loadbar, 4PS, Drum No. 3	
	70168-04	Loadbar, 4PS, Drum No. 4	
	70166	Loadbar, 4PS, Drum No. 5	
	70166	Loadbar, 4PS, Drum No. 6	
2	70185	Pin, 2PS, Drum Nos. 1 & 2	2
		Pin, 4PS, Drum Nos. 3 & 4	
2	70164	Pin, 4PS, Drum Nos. 5 & 6	1
3	PA3796	Cotter Pin	(a)

No Recommended Spare Parts

NOTE:

(a) Quantity of 4 required when 2 pins are used, and quantity of 2 required when 1 pin is used.

HAND-GEARED TROLLEY DRIVE

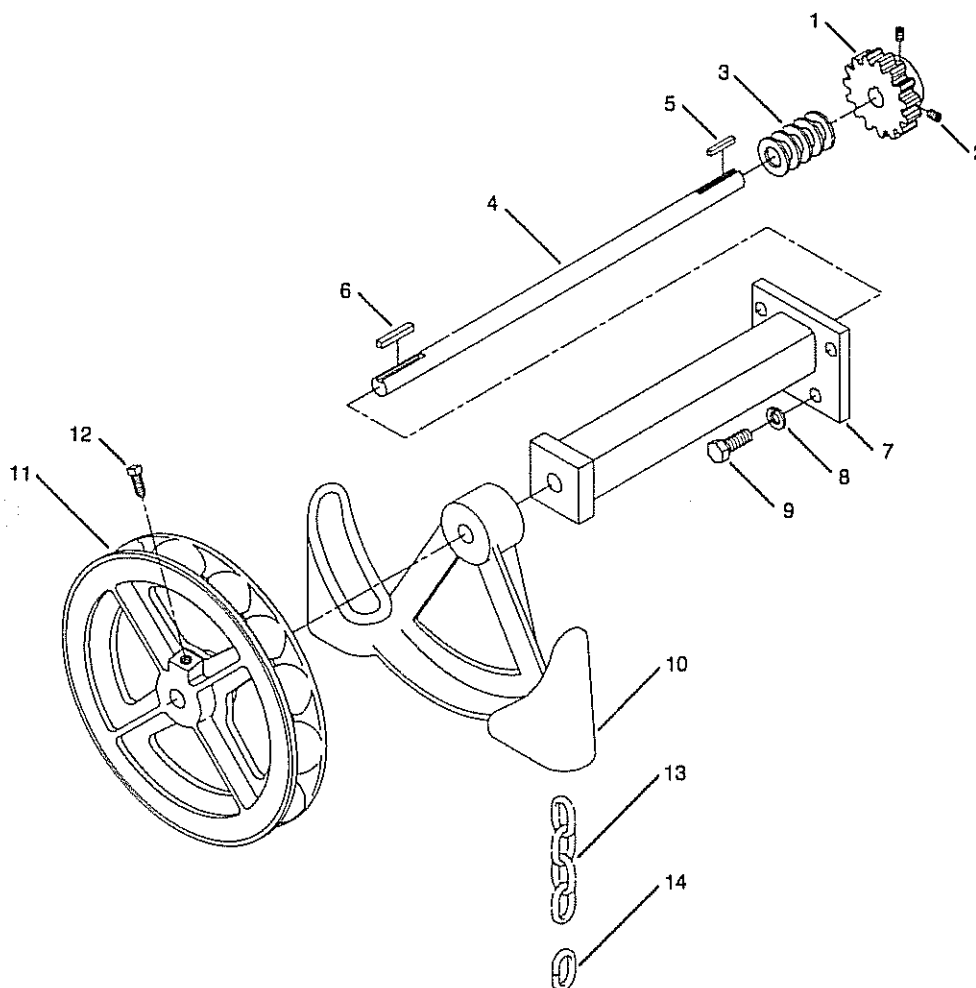

HAND-GEARED TROLLEY DRIVE PARTS

ITEM NO.	PART NUMBER	DESCRIPTION	QTY
1	69788	Pinion 15T	1
2	12-5-4	Set Screw 5/16-18x1/4	2
3	15-12-1C	Washer	5
4	69798-02	Shaft	1
5	52674	Key 3/16 Sq. x 1-1/4	1
6	PA6956	Key 1/4 Sq. x 1-5/8	1
7	69803-02	Bearing	1

ITEM NO.	PART NUMBER	DESCRIPTION	QTY
8	17-8C	Lockwasher 1/2	4
9	35-8-20C	Bolt 1/2-13x1-1/4	4
10	B2143-1	Handchain Guide	1
11	B464-4	Handwheel	1
12	14-6-16	Set Screw	1
13	(a)	Handchain	1
14	(a)	Open Link	1

No Recommended Spare Parts

NOTES:

- (a) When ordering handchain, order Part Number (see below) and specify length.
- (b) Federal Specification QQ-Z-325, Type I, Class 3.
- (c) Federal Specification QQ-Z-325, Type I, Class 2.

TYPE OF TROLLEY	CHAIN MATERIAL	HANDCHAIN	OPEN LINK
Steel Wheels	Steel, Zinc Electro Plated (Acco Std) (b)	48158-1	60252-01
Steel Wheels	Steel, Zinc Electro Plated (c)	48158-11	60252-11
Bronze Wheels	Aluminum	48159-1	PA3985

MOTORIZED MONORAIL TROLLEY DRIVE

MOTORIZED MONORAIL TROLLEY DRIVE PARTS

ITEM NO.	PART NO.	DESCRIPTION	QTY.
1	69788	Pinion (15 teeth)	1
2	12-5-4	Set Screw	2
3	17-8C	Lockwasher	4
4	35-8-20C	Hex Head Bolt	4
5	(a)	Right-Angle Gear Reducer	1
6	(b)	Motor	1
Not Shown	69807	EP Moly D Grease	(c)

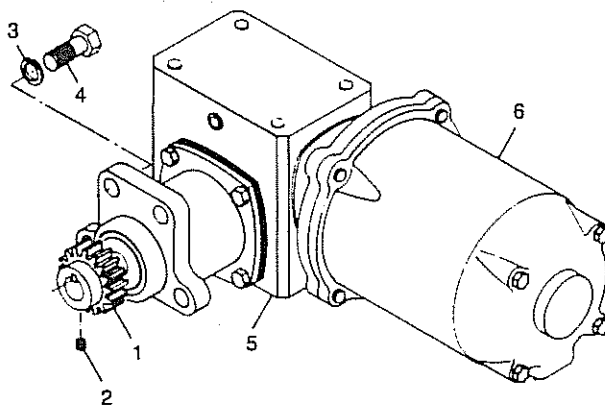

No Recommended Spare Parts

NOTES:

(a) Select right-angle gear reducer as specified from the following:

- 50 FPM, Part No. 60823-42, 20:1 Reduction, (standard speed).
- 100 FPM, Part No. 60823-52, 10:1 Reduction, (standard speed).
- 33 FPM, Part No. 60823-72, 30:1 Reduction, (non-standard speed).
- 65 FPM, Part No. 60823-82, 15:1 Reduction, (non-standard speed).
- 125 FPM, Part No. 60823-92, 7.5:1 Reduction, (non-standard speed).

(b) Trolley motor brake is optional on motorized right-angle gear reducer monorail trolley drive. Motors for trolley drive without motor brake have one shaft extension. Motors for trolley drive with motor brake have two shaft extensions. Select motor as specified from the following:

Motors for standard drive without motor brake.

- Part No. 61010-01, Single speed, 1/2 hp, 1800 rpm, frame 56C, 200 volt.
- Part No. 61010-02, Single speed, 1/2 hp, 1800 rpm, frame 56C, 208/230/460 volt.
- Part No. 61010-03, Single speed, 1/2 hp, 1800 rpm, frame 56C, 575 volt.
- Part No. 61010-04, Single speed, 1 hp, 1800 rpm, frame 56C, 200 volt.
- Part No. 61010-05, Single speed, 1 hp, 1800 rpm, frame 56C, 208/230/460 volt.
- Part No. 61010-06, Single speed, 1 hp, 1800 rpm, frame 56C, 575 volt.
- Part No. 61012-01, Two speed, 1/2 hp, 1800/600 rpm, frame 56C, 200 volt.
- Part No. 61012-02, Two speed, 1/2 hp, 1800/600 rpm, frame 56C, 230 volt.
- Part No. 61012-03, Two speed, 1/2 hp, 1800/600 rpm, frame 56C, 460 volt.
- Part No. 61012-04, Two speed, 1/2 hp, 1800/600 rpm, frame 56C, 575 volt.
- Part No. 61012-05, Two speed, 1 hp, 1800/600 rpm, frame 56C, 200 volt.
- Part No. 61012-06, Two speed, 1 hp, 1800/600 rpm, frame 56C, 230 volt.
- Part No. 61012-07, Two speed, 1 hp, 1800/600 rpm, frame 56C, 460 volt.
- Part No. 61012-08, Two speed, 1 hp, 1800/600 rpm, frame 56C, 575 volt.

Motors for drive with optional motor brake.

- Part No. 65818-04, Single speed, 1/2 hp, 1800 rpm, frame 56C, 200 volt.
 - Part No. 65818-05, Single speed, 1/2 hp, 1800 rpm, frame 56C, 208/230/460 volt.
 - Part No. 65818-06, Single speed, 1/2 hp, 1800 rpm, frame 56C, 575 volt.
 - Part No. 65818-10, Single speed, 1 hp, 1800 rpm, frame 56C, 200 volt.
 - Part No. 65818-11, Single speed, 1 hp, 1800 rpm, frame 56C, 208/230/460 volt.
 - Part No. 65818-12, Single speed, 1 hp, 1800 rpm, frame 56C, 575 volt.
 - Part No. 65819-01, Two speed, 1/2 hp, 1800/600 rpm, frame 56C, 200 volt.
 - Part No. 65819-02, Two speed, 1/2 hp, 1800/600 rpm, frame 56C, 230 volt.
 - Part No. 65819-03, Two speed, 1/2 hp, 1800/600 rpm, frame 56C, 460 volt.
 - Part No. 65819-04, Two speed, 1/2 hp, 1800/600 rpm, frame 56C, 575 volt.
 - Part No. 65819-09, Two speed, 1 hp, 1800/600 rpm, frame 56C, 200 volt.
 - Part No. 65819-10, Two speed, 1 hp, 1800/600 rpm, frame 56C, 230 volt.
 - Part No. 65819-11, Two speed, 1 hp, 1800/600 rpm, frame 56C, 460 volt.
 - Part No. 65819-12, Two speed, 1 hp, 1800/600 rpm, frame 56C, 575 volt.
- For other specified special motors, refer to additional information pages supplied with manual.

(c) Exposed gears and pinions on trolleys are shipped from the factory without lubricant. Lyondell® EP Moly D Grease, packaged in a 4-ounce squeeze bottle container, is furnished with all hoists that have trolleys specified. Refer to LUBRICATION section of Manual 69833: Installation, Operation, and Maintenance Manual for WRIGHT® WORK-RATED® Wire Rope Electric Hoists. Additional containers of Lyondell® EP Moly D Grease, packaged in a 4-ounce squeeze bottle, can be obtained by ordering Acco® part no. 69807.

MOTORIZED MONORAIL TROLLEY
RIGHT-ANGLE GEAR REDUCER

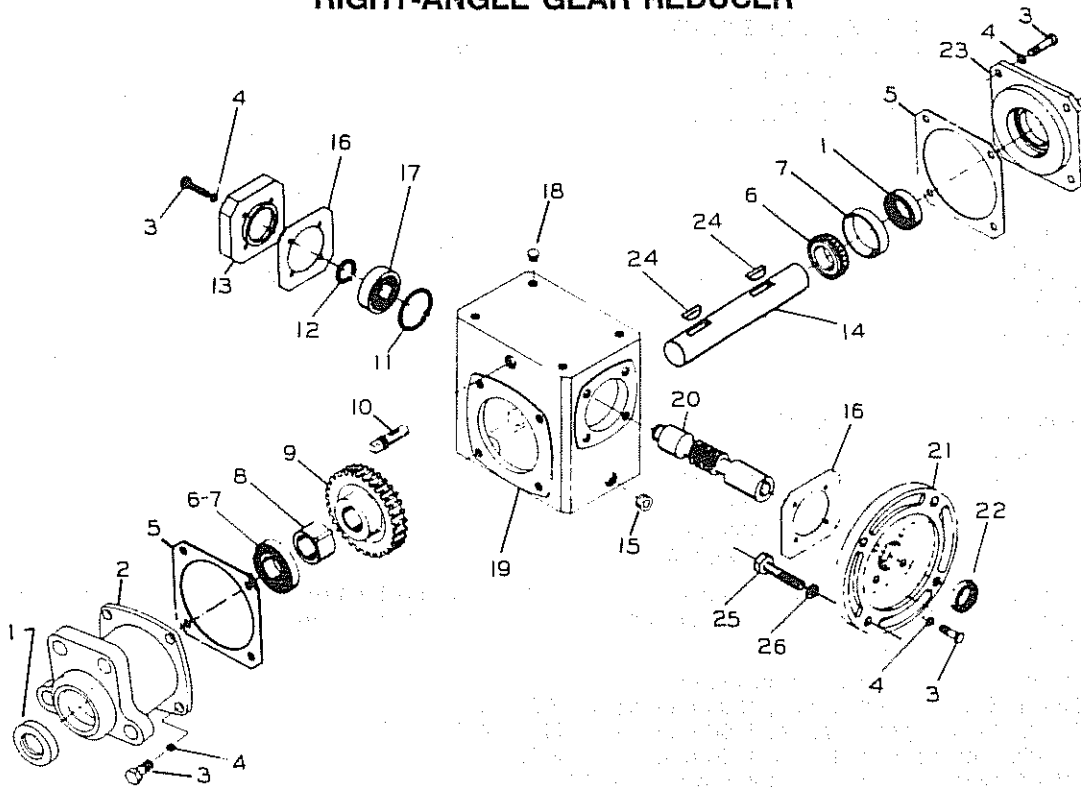

RIGHT-ANGLE GEAR REDUCER PARTS

ITEM NO.	PART NUMBER	DESCRIPTION	QTY/ ASSY
1	V93005	Oil Seal	2▲
2	V28256C	Adapter	1
3	35-4-14	Hex Head Cap Screw, 1/4-20x7/8	16
4	17-4C	Lock Washer, 1/4	16
	V49020A	Output Cover Gasket	2
5	V49021A	Gasket Cover .010 Vellumoid	AR
	V49022A	Gasket Cover .015 Vellumoid	AR
6	V40831	Output Bearing (Cone)	2
7	V40832	Output Bearing (Cup)	2
8	V41526A	Gear Spacer	1
9	V25014B	Worm Gear 5:1	1
	V25015B	10:1	1
	V25017B	20:1	1
10	V41752	Vent Plug	1
11	V40260	Retaining Ring (Housing) Internal	1
12	V41050	Retaining Ring (Shaft) External	1

ITEM NO.	PART NUMBER	DESCRIPTION	QTY/ ASSY
13	V48002B	Input Cover (Bearing)	1
14	V36732B	Output Shaft	1
15	V40411	Pipe Plug	6
16	V49017A	Input Cover Gasket	2
	V49018A	Gasket Cover .010 Vellumoid	AR
	V49019A	Gasket Cover .015 Vellumoid	AR
17	V40257	Input Bearing	1
18	V40813	Protective Plug	8
19	V29000D	Gear Housing	1
NS	V95102A	Splash Guard	1
20	V12034B	Quill Input Shaft 5:1	1
	V12035B	10:1	1
	V12037B	20:1	1
21	V28046D	Quill Motor Flange	1
22	V40770	Oil Seal	1▲
23	V48049B	Output Cover (Bearing)	1
24	PA1357	Woodruff Key	2
25	35-6-16	Hex Head Cap Screw, 3/8-16x1	4
26	17-6C	Lock Washer, 3/8	4

▲ Recommended Spare Parts

NOTE:

For worm gear (Item No. 9) and quill input shaft (Item No. 20) for 7.5:1, 15:1 and 30:1 ratios, contact Acco Chain & Lifting Products or the distributor of the hoist.

MOTORIZED TOP-RUNNING TROLLEY DRIVE ASSEMBLY

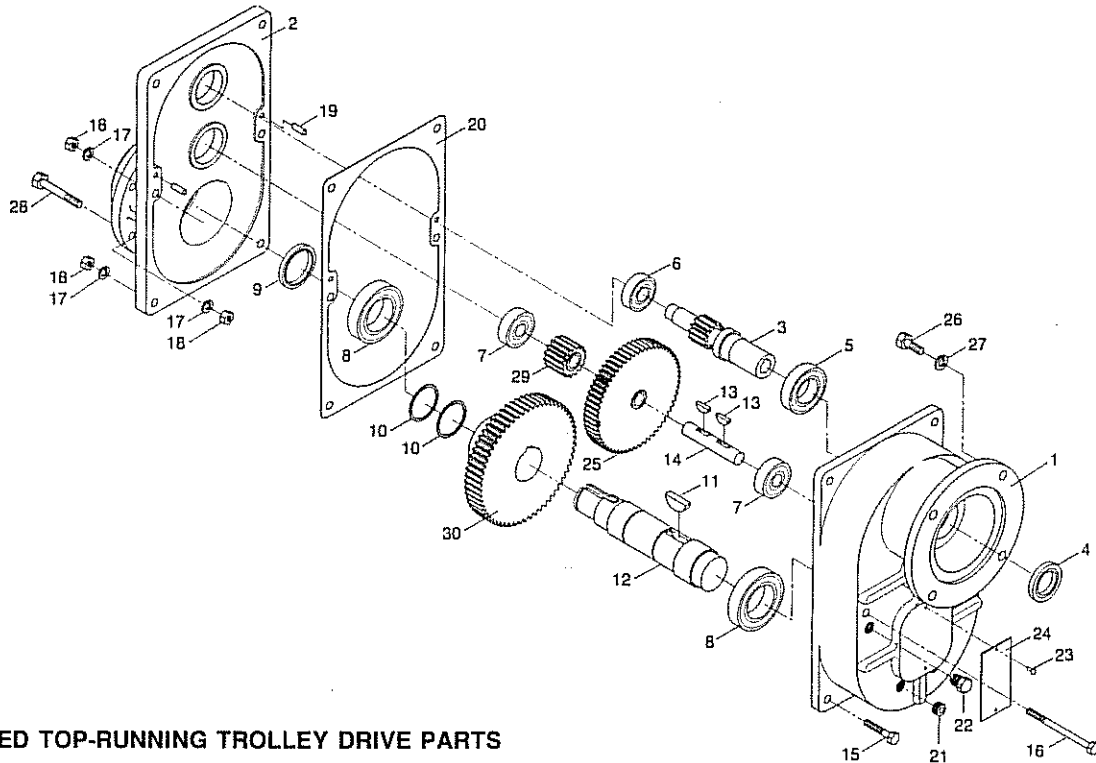

MOTORIZED TOP-RUNNING TROLLEY DRIVE PARTS

ITEM NO.	PART NUMBER	DESCRIPTION	QTY/ ASSY
1	69407	Input Reducer Housing	1
2	69409	Output Reducer Housing	1
3	69415	Motor Pinion Shaft	1
4▲	PA6662	Oil Seal	1
5	PA6655	Bearing	1
6	PA2464	Bearing	1
7	PA1129	Bearing	2
8	PA1569	Bearing	2
9▲	PA1993	Oil Seal	1
10	PA7349	Retaining Ring	2
11	PA1416	Woodruff Key	1
12	69417	Output Shaft	1
13	PA1175	Woodruff Key	2
14	69416	Intermediate Shaft	1
15	35-5-24	Bolt 5/16-18 x 1-1/2	4
16	35-5-60	Bolt 5/16-18 x 3-3/4	2
17	17-5C	Lockwasher 5/16	10

ITEM NO.	PART NUMBER	DESCRIPTION	QTY/ ASSY
18	22-5C	Hex Nut 5/16-18	10
19	PA5439	Dowel Pin	2
20▲	69405	Gasket	1
21	PA786	Hex Socket Pipe Plug	3
22	PA7350	Breather Plug	1
23	PA897	Drive Pin	2
24	69106	Serial Plate	1
25	69414	Intermediate Gear	1
26	35-6-16	Motor Mounting Bolt 3/8-16 x 1	4
27	17-6C	Lockwasher 3/8	4
28	35-5-24	Reducer Mtg. Bolt 5/16-18 x 1-1/2	4
	35-5-36	Reducer Mtg. Bolt 5/16-18 x 2-1/4	

TROLLEY SPEED	40-50 FPM	65-75 FPM	95-110 FPM
GEAR BOX RATIO	23:1	15:1	10:1
ITEM 29 PART NO.	69411	69412	69413
ITEM 30 PART NO.	B4073	B4074	B4075

▲ Recommended Spare Parts

NOTES:

- (a) Pinion assembled on top-running trolley drive output shaft that meshes with top-running trolley geared wheel is not shown. Parts required are one each of: 51291, Pinion; 68290, key, and PA3269, Retaining Ring.
- (b) Trolley motor brake is standard on motorized top-running trolley drive. Motors for trolley drive with motor brake have two shaft extensions. Select motor with two shaft extensions as specified on page 31.
- (c) Exposed gears and pinions on trolleys are shipped from the factory without lubricant. Lyondell® EP Moly D Grease, packaged in a 4-ounce squeeze bottle container, is furnished with all hoists that have trolleys specified. Refer to LUBRICATION section of Manual 69833: Installation, Operation, and Maintenance Manual for WRIGHT® WORK-RATED® THE NEW CENTURY SERIES™ Wire Rope Electric Hoists. Additional containers of Lyondell® EP Moly D Grease, packaged in a 4-ounce squeeze bottle, can be obtained by ordering Acco® part no. 69807.

TROLLEY MOTOR BRAKE ASSEMBLY

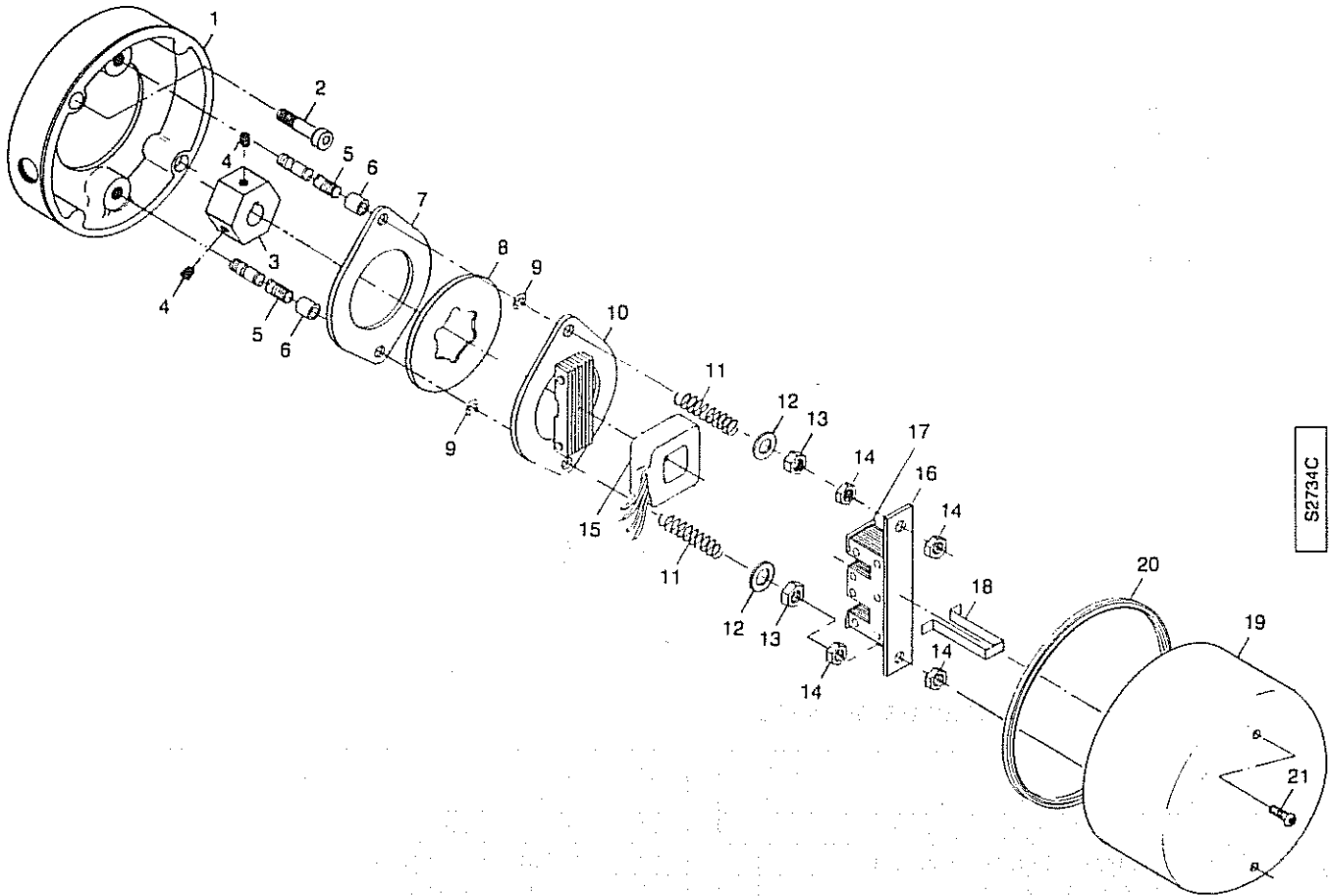

S2734C

TROLLEY MOTOR BRAKE PARTS

ITEM NO.	PART NUMBER	DESCRIPTION	QTY/ ASSY
1	65653	Adapter	1
2	1-6-24	Bolt, 3/8-16 x 1-1/2 lg	2
3	65654	Hub	1
4	12-4-6	Set Screw	2
5	65655	Stud	2
6	61459	Spacer	2
7	39794	Brake Plate	1
8▲	39649	Brake Lining	1
9	PA5623	Retaining Ring	2
10	39781	Pressure Unit	1
11	PA5823	Spring	2
12	15-6-1	Flat Washer	2

ITEM NO.	PART NUMBER	DESCRIPTION	QTY/ ASSY
13	PA2377	Locknut	2
14	24-6	Jam Nut, 3/8	4
15▲		Coil	1
	39783-2	575 VAC	
	39783-3	230/460 VAC	
	39783-6	208 VAC	
16	39780	Magnet Unit	1
17	39784	Shading Coil (a)	2
18	39877	Coil Strap	1
19	69161	Brake Cover	1
20	PA7110	Gasket	1.77 ft
21▲	PA7323	Screw, LOC-WEL, #10-24 (b)	2

▲ Recommended Spare Parts

(a) Shading Coil is furnished with Magnet Unit, but also available as a spare.

(b) Screw with self-locking feature must be utilized. Substitutes are not permissible.

DECK MOUNTED FRAME

DECK MOUNTED FRAME PARTS

ITEM NO.	DESCRIPTION	QUANTITY	PART NO.
1	End Plate, Deck Mounted Gear End	1	70224
2	End Plate, Deck Mounted Control End	1	70225
3	Frame, 2-Part Single, Drum 1	1	70212-01
	Frame, 2-Part Single, Drum 2		70212-02
	Frame, 2-Part Single, Drum 3		70253-03
	Frame, 2-Part Single, Drum 4		70253-04
	Frame, 2-Part Single, Drum 5		70253-05
	Frame, 2-Part Single, Drum 6		70253-06
3	Frame, 2-Part Double, Drum 2	1	70209-02
	Frame, 2-Part Double, Drum 3		70209-03
	Frame, 2-Part Double, Drum 4		70209-04
	Frame, 2-Part Double, Drum 5		70209-05
	Frame, 2-Part Double, Drum 6		70255-06
3	Frame, 4-Part Single, Drum 3	1	70169-03
	Frame, 4-Part Single, Drum 4		70169-04
	Frame, 4-Part Single, Drum 5		70254-05
	Frame, 4-Part Single, Drum 6		70254-06
3	Frame, 4-Part Double, Drum 4	1	70256-04
	Frame, 4-Part Double, Drum 5		70256-05
	Frame, 4-Part Double, Drum 6		70267-06

Note:

For part numbers of other parts shown, refer to page 9 for 2PS reeving, page 10 for 4PS reeving, page 11 for 2PD reeving, or page 12 for 4PD reeving.

No Recommended Spare Parts

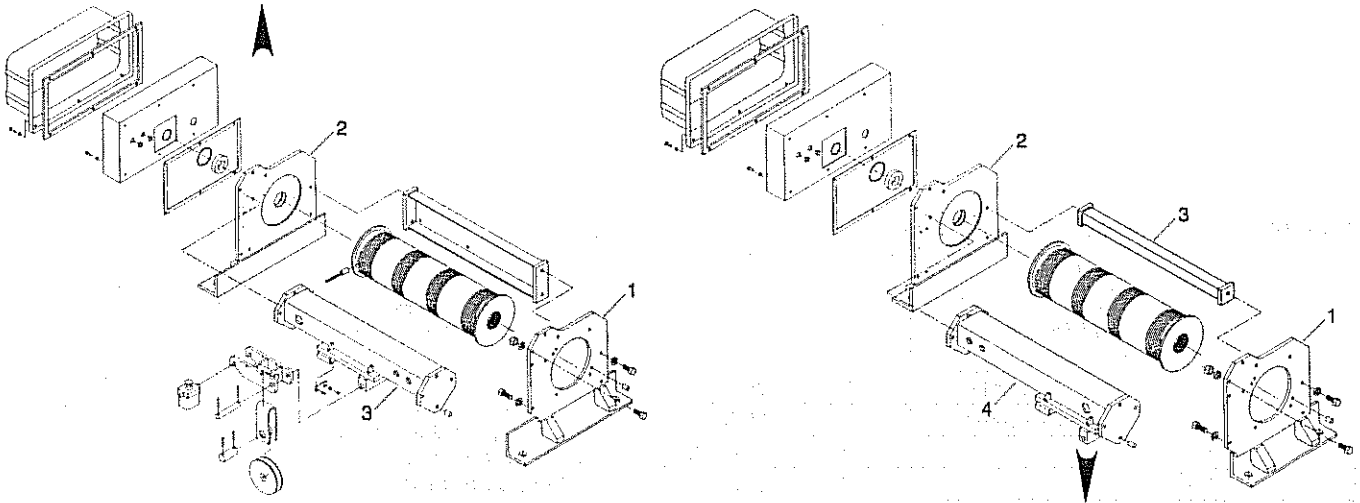

WINCH UNIT FRAME

WINCH UNIT FRAME PARTS

ITEM NO.	DESCRIPTION	QUANTITY	PART NO.
1	End Plate, Winch Gear End	1	70226
2	End Plate, Winch Control End	1	70227
3	Side Frame, Winch	1	(a)
4	Frame, Winch	1	(a)

No Recommended Spare Parts

Note:

For part numbers of other parts shown, refer to page 9 for 2PS reeving, page 10 for 4PS reeving, page 11 for 2PD reeving, or page 12 for 4PD reeving.

(a) Winch side frame part number 70210-XX and winch frame part number 70260-XX are available in various lengths. Contact Acco Chain & Lifting Products or the distributor of the hoist with hoist product number and/or hoist serial number.

TOP-RUNNING TROLLEY

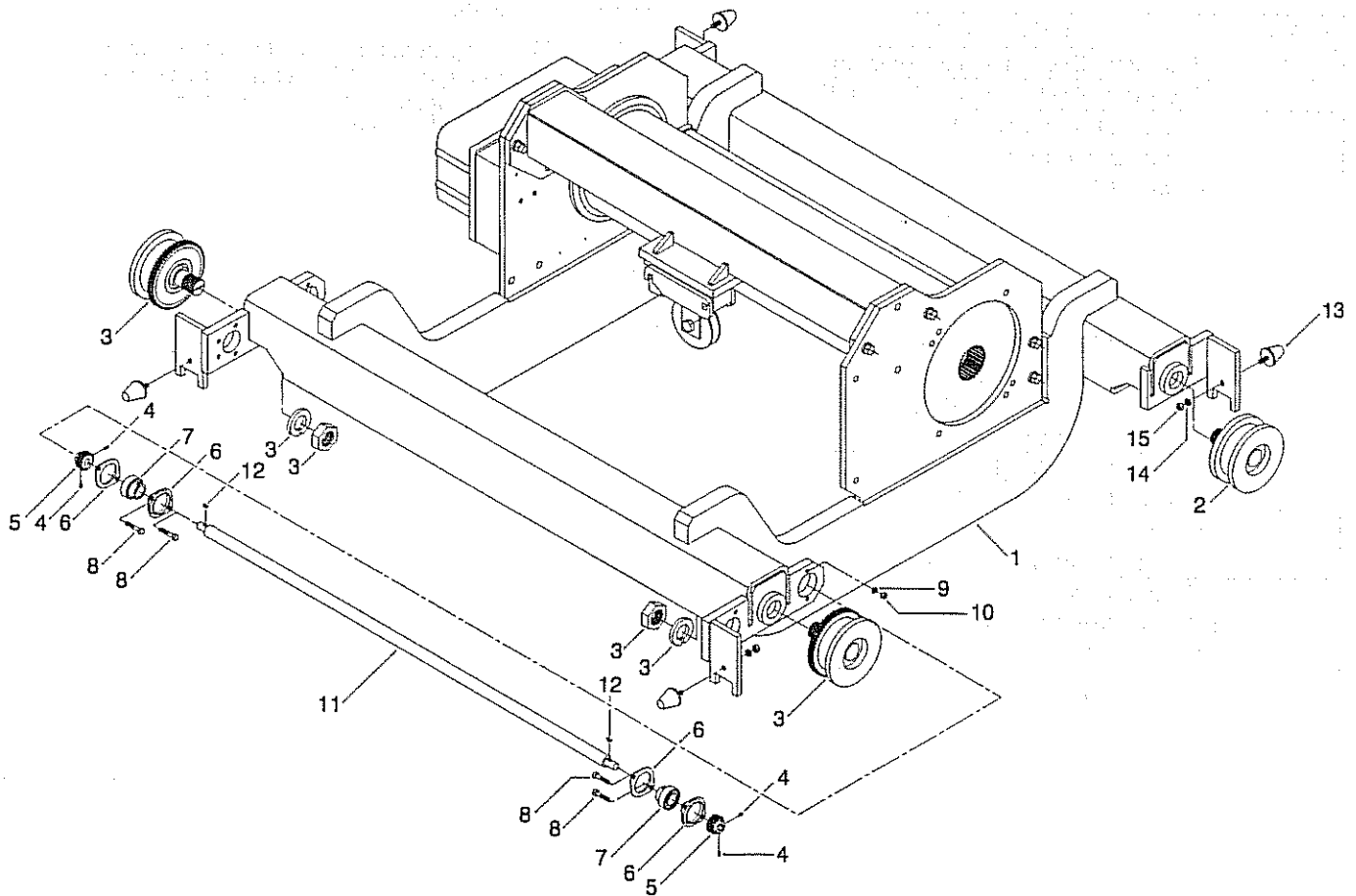

TOP-RUNNING TROLLEY FRAME PARTS

ITEM NO.	DESCRIPTION	QUANTITY	PART NO.
1	Trolley Frame, Trolley End Beams, End Plates, Gear End and Control End	1	(a)
2	Plain Wheel Assembly	2	70237-02
3	Geared Wheel Assembly	2	70237-01
4	Set Screw	4	12-4-4C
5	Pinion	2	62214
6	Bearing Flange	4	PA6154
7	Bearing	2	PA6153
8	Hex Head Bolt	4	35-6-28
9	Lockwasher	4	17-6C
10	Nut	4	22-6
11	Shaft, Wheel Gage 60"	1	69335-03
11	Shaft, Wheel Gage 78"	1	69335-04
11	Shaft, Wheel Gage 96"	1	69335-05
12	Woodruff Key	2	PA1357
13	Bumper (Optional)	4	65226
14	Lockwasher (Optional)	4	17-7
15	Nut (Optional)	4	22-7

Notes:

For part numbers of other suspension frame parts, refer to page 10 for 4PS reeving, page 11 for 2PD reeving, or page 12 for 4PD reeving.

(a) Trolley side frame, trolley end beams, and hoist end plates are a single welded unit. Contact Acco Chain & Lifting Products or the distributor of the hoist with hoist product number and/or hoist serial number; and wheel gage of trolley.

(b) When dual motorized trolley drives are used, item numbers 4, 5, 6, 7, 8, 9, 10, 11 and 12 are not used.

No Recommended Spare Parts

LOADBAR ASSEMBLY – FOR SWIVELING TROLLEYS

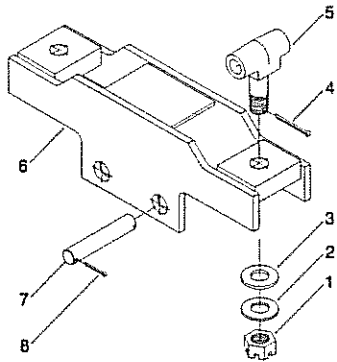

FIGURE A

2 PART SINGLE DRUM NO. 1

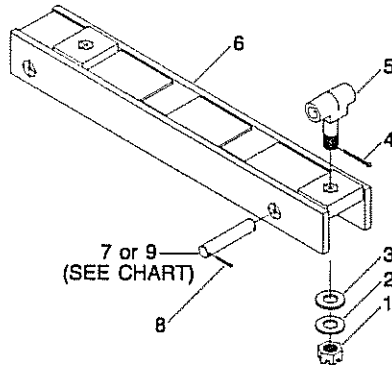

FIGURE B

2 PART SINGLE DRUM NOS. 2, 3, 4, 5, 6

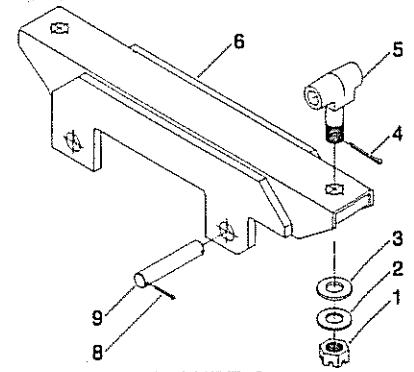

FIGURE C

4 PART SINGLE DRUM NOS. 3, 4

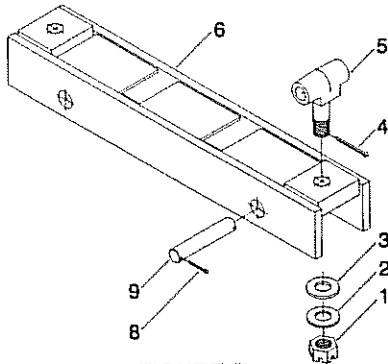

FIGURE D

4 PART DOUBLE DRUM NOS. 4, 5, 6

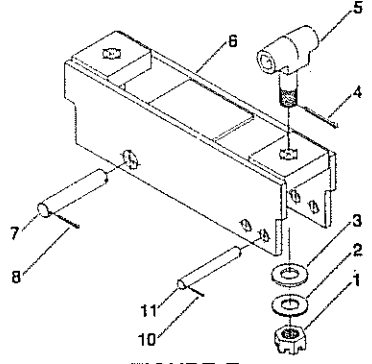

FIGURE E

2 PART DOUBLE DRUM NO. 2

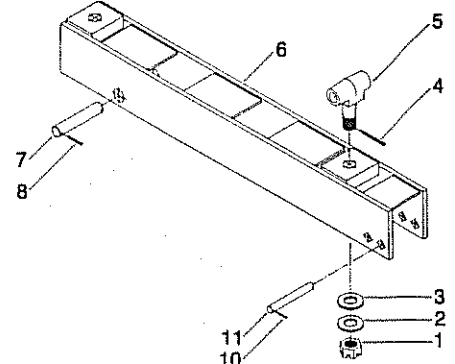

FIGURE F

2 PART DOUBLE DRUM NOS. 3, 4, 5, 6

LOADBAR PARTS

REFER TO FIGURE		A, B (DRUM 2)		B (DRUMS 3, 4, 5, 6), C, D		E, F	
ITEM. NO.	DESCRIPTION	PART NUMBER	QTY	PART NUMBER	QTY	PART NUMBER	QTY
1	Hex Slotted Nut	26-28	2	26-28	2	26-28	2
2	Thrust Washer	A4421	2	A4421	2	A4421	2
3	Thrust Bearing	A4420	2	A4420	2	A4420	2
4	Cotter Pin	PA1484	2	PA1484	2	PA1484	2
5	Suspension Stud	63161	2	63161	2	63161	2
6	Loadbar	(a) (b)	1	(a) (b)	1	(a) (b)	1
7	Pin	63029-05	2	—	—	63029-05	1
8	Cotter Pin	PA1484	4	PA1484	4	PA1484	2
9	Pin	—	—	63029-01	2	—	—
10	Cotter Pin	—	—	—	—	PA1771	4
11	Pin	—	—	—	—	63295-03	2

No Recommended Spare Parts

NOTES:

For trolley parts, refer to pages 26, 27, and 28.

(a) Loadbar part numbers for:

FIGURE A	FIGURE B	FIGURE C	FIGURE D	FIGURE E	FIGURE F
70272-01	70273-02	70282-03	70280-04	70288-02	70286-03
	70267-03	70282-04	70280-05		70286-04
	70267-04		70280-06		70286-05
	70267-05				70286-06
	70267-06				

(b) Dash number (-03, -04, etc.) indicates corresponding hoist drum length.

Example: 70282-03 for Drum No. 3, 70282-04 for Drum No. 4, etc.

OPTIONAL ELECTRICAL CONTROL ENCLOSURE

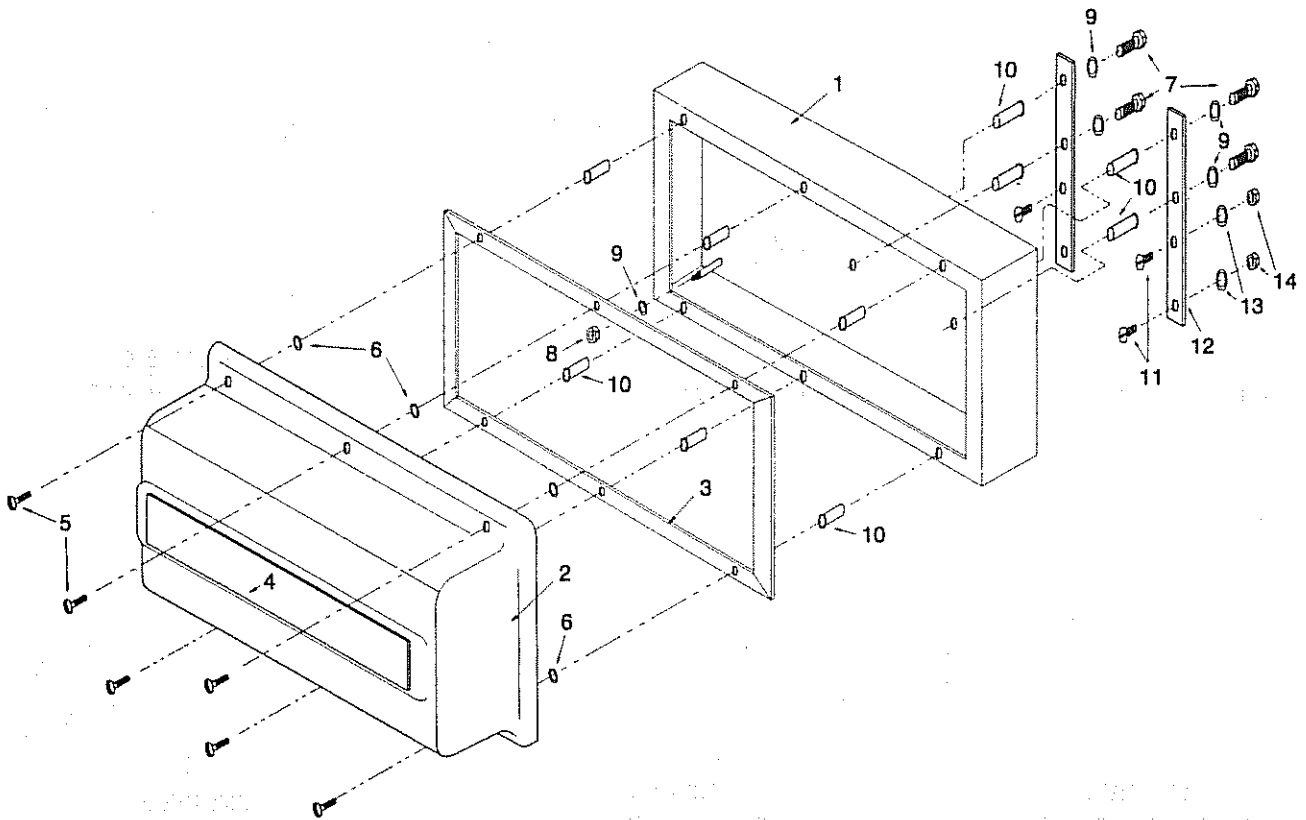

REPLACEMENT PARTS

ITEM NO.	PART NO.	DESCRIPTION	QUANTITY BY ENCLOSURE SIZE		
			11" x 21"	15" x 21"	21" x 21"
1	69829-1	Enclosure, 11 x 21	1	N/A	N/A
	69828-1	Enclosure, 15 x 21	N/A	1	N/A
	69875-1	Enclosure, 21 x 21	N/A	N/A	1
2	52823	Cover, 11 x 21	1	N/A	N/A
	52826	Cover, 15 x 21	N/A	1	N/A
	54268	Cover, 21 x 21	N/A	N/A	1
3	58531	Gasket, 11 x 21	1	N/A	N/A
	55204	Gasket, 15 x 21	N/A	1	N/A
	55206	Gasket, 21 x 21	N/A	N/A	1
4	55224-2	Label	1	1	1
5	58597	Screw, Captive	6	6	8
6	PA6634	Ring, Retaining	6	6	8
7	35-4-12	Hex Head Bolt	4	4	4
8	22-4C	Hex Nut	4	4	4
9	17-4C	Lockwasher	8	8	8
10	PA7343	Nut Insert, Closed End	10	10	12
11	5-6-20	Flathead Screw	4	4	4
12	69808	Enclosure Mounting Strap	2	2	2
13	17-6C	Lockwasher	4	4	4
14	22-6	Hex Nut	4	4	4

GENERAL CONDITIONS OF WARRANTY

WARRANTIES: The Seller warrants to the original using Buyer thereof that the goods sold under this Agreement are free from defects in workmanship and materials for a period of one year from the date of shipment to the original using Buyer. No other express warranties are given and no affirmation of Seller or Seller's agents, by word or action, shall constitute a warranty. No warranty is made for components and accessories made by others when such items are warranted by their respective manufacturers.

Installation or operation of the equipment in any manner other than as recommended by Seller, shall void the warranty.

Any variations in details between the goods furnished herein and those covered in Buyer's specifications are due to standards of manufacture not to be construed as exceptions to the specifications.

DISCLAIMER OF IMPLIED WARRANTIES:

- (a) SELLER MAKES NO WARRANTY OF MERCHANTABILITY IN RESPECT TO THE GOODS SOLD UNDER THIS AGREEMENT.
- (b) This sale is made WITHOUT ANY WARRANTY BY SELLER THAT THE GOODS ARE SUITABLE FOR ANY PARTICULAR PURPOSE.
- (c) Buyer hereby waives all other warranties, guarantees, obligations, liabilities, rights, and remedies arising by law or otherwise including any obligation or liability of the Seller arising from tort, and Buyer shall indemnify Seller from any liability, loss, damage, or claim arising from Buyer's tortious use of the goods sold hereby.

REMEDIES:

- (a) Under no conditions shall any goods be returned to Seller without its prior written consent.
- (b) The Buyer's sole and exclusive remedy for breach of any warranty is limited to Seller furnishing, at its expense, duplicate or repaired parts F.O.B. Seller's plant with installation at Buyer's expense if discovery of a claimed defect occurs during the allowable warranty period, and if Seller's inspection determines a defect exists.
- (c) The quantity of material shown by invoice shall in all cases govern settlement for shortages, unless notice of shortage, appropriately documented, is given to the carrier and the Seller upon delivery by the Carrier.
- (d) Claims for errors, deficiencies or imperfections shall be deemed waived by the Buyer unless Seller is notified in writing of the basis of such claims within 10 days after discovery of claimed defect and such discovery occurs within the warranted period.
- (e) Neither Buyer nor User shall be entitled under this Agreement to recover from Seller any incidental or consequential damages of any nature including but not limited to the cost of any labor expended by others in connection with the goods sold hereby by reason of any alleged nonconformity or breach of warranty on the part of the Seller, nor costs of material or account thereof, nor any lost profits whether determinable or speculative.



Acco Chain & Lifting Products Division

76 Acco Drive, Box 792, York, PA 17405-0792
717-741-4863 800-967-7333 Fax 717-741-8572