

Saf-T-Bar Conductor Bar H Series

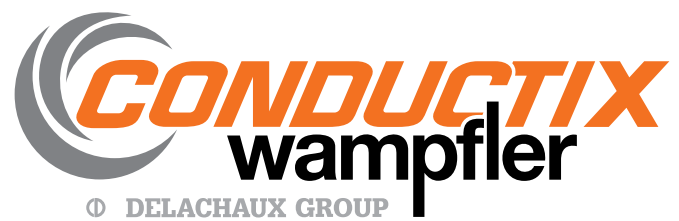

The technical data and images which appear in this manual are for informational purposes only. **NO WARRANTIES, EXPRESS OR IMPLIED, INCLUDING WARRANTIES OF MERCHANTABILITY OR FITNESS FOR A PARTICULAR PURPOSE, ARE CREATED BY THE DESCRIPTIONS AND DEPICTIONS OF THE PRODUCTS SHOWN IN THIS MANUAL.** Conductix makes no warranty (and assumes no liability) as to function of equipment or operation of systems built according to customer design or of the ability of any of its products to interface, operate or function with any portions of customer systems not provided by Conductix.

Seller agrees to repair or exchange the goods sold hereunder necessitated by reason of defective workmanship and material discovered and reported to Seller within one year after shipment of such goods to Buyer.

Except where the nature of the defect is such that it is appropriate, in Seller's judgment, to effect repairs on site, Seller's obligation hereunder to remedy defects shall be limited to repairing or replacing (at Seller's option) FOB point of original shipment by Seller, any part returned to Seller at the risk and cost of Buyer. Defective parts replaced by Seller shall become the property of Seller.

Seller shall only be obligated to make such repair or replacement if the goods have been used by Buyer only in service recommended by Seller and altered only as authorized by Seller. Seller is not responsible for defects which arise from improper installation, neglect, or improper use or from normal wear and tear.

Additionally, Seller's obligation shall be limited by the manufacturer's warranty (and is not further warranted by Seller) for all parts procured from others according to published data, specifications or performance information not designed by or for Seller.

Seller further agrees to replace or at Seller's option to provide a refund of the sales price of any goods that do not conform to applicable specifications or which differ from that agreed to be supplied which non-conformity is discovered and forthwith reported to Seller within thirty (30) days after shipment to the Buyer. Seller's obligation to replace or refund the purchase price for non-conforming goods shall arise once Buyer returns such goods FOB point of original shipment by Seller at the risk and cost of Buyer. Goods replaced by Seller shall become the property of Seller.

There is no guarantee or warranty as to anything made or sold by Seller, or any services performed, except as to title and freedom from encumbrances and, except as herein expressly stated and particularly, and without limiting the foregoing, **there is no guarantee or warranty, express or implied, of merchantability or of fitness for any particular purpose or against claim of infringement or the like.**

Seller makes no warranty (and assumes no liability) as to function of equipment or operation of systems built to Buyer's design or of the ability of any goods to interface, operate or function with any portions of Buyer's system not provided by Seller.

Seller's liability on any claim, whether in contract, tort (including negligence), or otherwise, for any loss or damage arising out of, connected with, or resulting from the manufacture, sale, delivery, resale, repair, replacement or use of any products or services shall in no case exceed the price paid for the product or services or any part thereof which give rise to the claim. In no event shall Seller be liable for consequential, special, incidental or other damages, nor shall Seller be liable in respect of personal injury or damage to property not the subject matter hereof unless attributable to gross misconduct of Seller, which shall mean an act or omission by Seller demonstrating reckless disregard of the foreseeable consequences thereof.

Seller is not responsible for incorrect choice of models or where products are used in excess of their rated and recommended capacities and design functions or under abnormal conditions. Seller assumes no liability for loss of time, damage or injuries to property or persons resulting from the use of Seller's products. Buyer shall hold Seller harmless from all liability, claims, suits and expenses in connection with loss or damage resulting from operation of products or utilization of services, respectively, of Seller and shall defend any suit or action which might arise there from in Buyer's name - provided that Seller shall have the right to elect to defend any such suit or action for the account of Buyer. The foregoing shall be the exclusive remedies of the Buyer and all persons and entitles claiming through the Buyer.

Overview - 4, 5

Voltage Drop Calculation - 4
Determining Amperage - 5

Mounting - 5

Plastic Hangers - 5
Anchor Clamp Kit - 5

Joining - 6

Power Feeds - 7

End Cap - 7
Cutting - 7
Transfer End Caps - 7

Expansion Gaps - 7

Expansion Gap Assemblies - 7
Isolation Joints - 7

Collectors - 8 thru 10

Parts List - 10

Overview

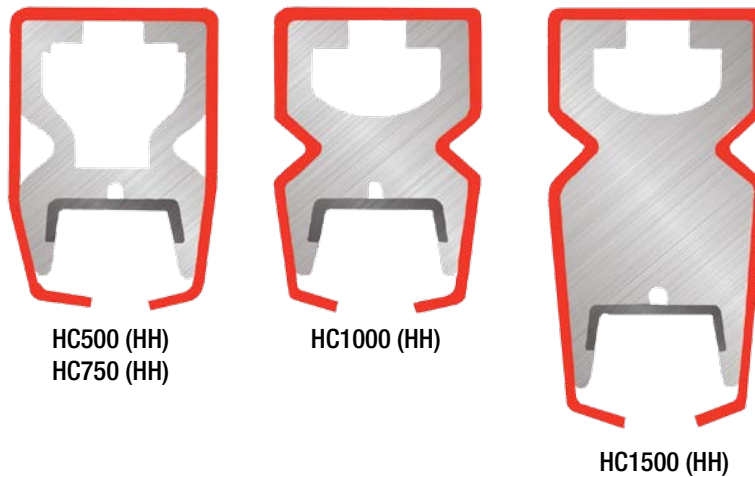

Conductor Cat No.	Amperage	Splice Joint	Power Feed	Hanger Assemblies for all Conductors	Expansion Gap Kit	End Cap
HC500X20	500	HA500J	HA500F	Standard Insulator Plastic	HA500XG-8"	HA1000N
HC750X20	750	HA750J	HA750F		HA1000H	HA1000N
HC1000X20	1000	HA1000J	HA1000F		HA1000K	HA1000N
HC1500X20	1500	HA1500J	HA1500F		HA1000P	HA1500N

Standard spool-type hanger assembly. 2-13/16" creep and 2-1/2" height.

Note: Refer to parts list for catalog variations.

- A** Standard rigid vinyl cover (prefix)
- H** Medium heat cover (plastic) (suffix)
- FI** High Heat Fiber Glass Cover (suffix)

For cranes and hoists
to 260° F, for cranes and hoists
to 375° F, for cranes and hoists

Hanger

As above
As above
Consult Factory

Conductor Rail				
Characteristics	HC500 (HH)	HC750 (HH)	HC1000 (HH)	HC1500 (HH)
Combined weight per foot	1.39	1.39	1.62	3.14
Weight of Aluminum per foot	0.90	0.90	1.12	2.60
Weight of Stainless Steel per foot	0.26	0.26	0.26	0.26
Weight of Vinyl per foot	0.23	0.23	0.23	0.28
"R" Resistance ohms/ft at 20°C	0.0000194	0.0000194	0.0000155	0.0000067
"Z" Impedance ohms/ft 3-1/2" c/c	0.0000301	0.0000301	0.0000279	0.0000389
"Z" Impedance ohms/ft 5.0" c/c	0.0000363	0.0000363	0.0000355	0.0000385
"AC" Resistance ohms/ft at 40°C	0.000021	0.000021	0.0000169	0.0000081

Voltage Drop Calculation

3 phase AC Volts lost = 1.73 x Z x Length in ft from feed x Amp load.
1 phase AV Volts lost = 2 x Z x Length in ft from feed x Amp load.
DC Volts lost = 2 x R x Length in ft. from feed x Amp load.

As most motors are designed to operate with a 5% voltage drop, divide volts lost by line voltage x 100 to determine if a larger conductor or additional feed points are required. *See tables for values of Z and R.*

Overview

Determining Amperage - The national electric code suggests the following when determining motor amperage loads:

- For one motor, use 100% of motor name-plate full load ampere rating.
- For multiple motors on a single crane or hoist, the minimum circuit ampacity of the power supply conductors on a crane or hoist shall be the nameplate full load ampere rating of the largest motor or group of motors for any single crane motion, plus 50% of the name plate full load ampere rating of the largest motor group of motors.
- For multiple cranes and/or hoists supplied by a common conductor system, compute the motor minimum capacity for each crane as in step (2), add them together and multiply the sum by the demand factor from the following table:

Number of cranes	2	3	4	5	6	7
Demand Factor	.95	.91	.87	.84	.81	.78

- For constant loads such as magnets, lights, and air conditioners, etc., plus high duty cycles, use full load amperage in selecting conductor size.

Mounting

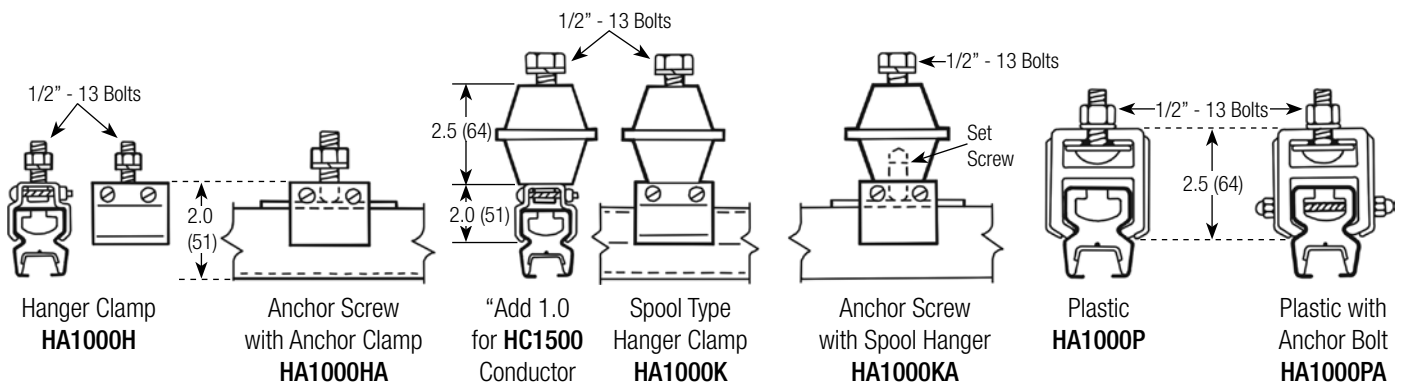

Mounting - It is suggested that the hanger clamp bracket be attached to the runway beam by welding or bolting. Conductors should be spaced 5 inches apart; however a minimum of 3.0 inches is acceptable. Hanger clamp brackets will require 9/16 inch holes for hanger clamp bolts of 1/2 inches. Conductor hanger clamps should be slid onto the rail and positioned relative to the approximate hanger clamp bracket so that when the rail is raised into place, the hanger clamps may be bolted to their respective bracket. Hanger clamp cross bolts should be tightened so that the rail will slide easily, but will be securely supported. To properly support the conductor and to keep standard rail overhang to 24 inches, space the first two brackets on 6 ft centers, all other brackets on 10 ft centers.

Anchor Clamp Kit for use with "H" and "K" hangers is an insulated keeper straddling each side of the standard hanger clamp. The hanger clamp mounting bolt is replaced by a cup point set screw that is tightened against the keeper plate at the desired hanger bracket location. On standard non-spool hangers, the set screw becomes the mounting bolt. On spool type hangers, the set screw is threaded into the base of the insulator spool.

An anchor hanger clamp comprises the selected systems hanger plus an anchor clamp kit or modification. They are designed with suffix "A", ie: **HA1000HA**.

Plastic Hangers are a slide-on insulating hanger for use on insulated series "H" conductors. They can be used in place of the coated or coated-plus insulator series hangers. Anchor type plastic hangers come with a drilled hole in the vertical stiffener on each side of the hangers. When the anchor and conductor are positioned as required, a drill is run through the conductor bar so that a threaded rod can be installed through the assembly, with each end protected by an insulating acorn nut.

Joining

Conductors are joined by a bolted splice assembly, comprised of two stacked spring plates located inside the hollow portion of the conductor so that as the assembly bolts are tightened, the stress goes to the outside of the concave strips and the strip edges align the adjacent conductor sections. The assembly, comprising the aluminum splice bars mounted on the outside top of the conductor, is torqued down by the steel bolts to 100 inch lbs. The longitudinal cavity in the main conductor body may be used as a heater wire location if heating is required. To join the adjacent conductor rails, abrade the joint surfaces of the conductor rail only, with a fine wire brush or abrasive cloth, coat thoroughly with Alcoa #2EJC compound immediately after abrading. *Do not abrade splice bars or terminals as they are tin plated to be corrosion free.* Assemble joint without removal of compound. Tighten assembly nuts until the joint is fully torqued. Snap the insulating splice cover into place to complete the joint. Make certain that the splice joints are at least 24 inches away from a hanger clamp to allow for adequate expansion and contraction movements of the rail assembly. Joints on H and FI Series are not illustrated. *Consult factory for details.*

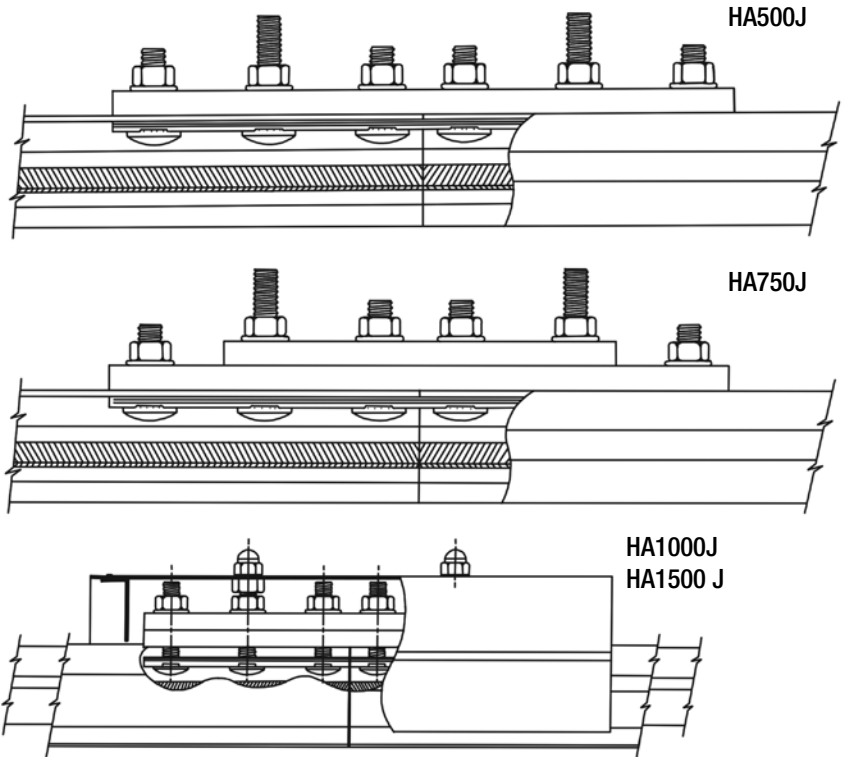

RAIL	COMPONENT DETAILS		EXPANSION GAP PARTS		
	3/8" JOINT PLATES	FEED TERMINAL & PLATE	GAP	END FEEDS	FLEX JUMPER & COVER
HC500	(1) 1.5" X 9.5" AL	(2) 350 MCM (1) 9.5" JOINT PLATE	8.0"	(2) 350 MCM	#3/0 X 48.0"
HC750	(1) 1.5" X 6.0" AL (1) 1.5" X 9.5" AL	(2) 350 MCM (1) 9.5" JOINT PLATE	8.0"	(2) 600 MCM	(2) #3/0 X 50.0"
HC1000	(2) 1.5" X 9.5" AL	(2) SINGLE LUGS W/14.0" COVER (2) 350 MCM (1) 6.0" CU PLATE	8.0"	(2) 350-2 MCM	(2) #3/0 X 50.0"
HC1500	(2) 1.5" X 9.5" CU	(2) 350-2 MCM (2) 9.5" CU PLATES	8.0"	(2) 600-2 MCM	(2) 350 MC X 50.0"

Power Feeds

Power Feeds for Supply Power connections are designed to be installed instead of a rail splice joint, where required. A suitable insulating cover is provided so that the terminal face is protected from accidental contact. Installation of protected feed joints is the same procedure as for regular power conductor rail splices. It is necessary to cut the insulating cover back by an additional 1.25 inches to accept the increase in length of a power feed over splice joint. Power feed conductor bar surfaces are prepared with electrical joint compound using the same procedure as on conductor splices. **HA500F / HA750F / HA1000F** power feeds have two 350MCM terminals. **HA1500F** power feeds have two 350-2 MCM terminals. Higher amperages are accomplished by grouping multiple terminals. Special feeds can be made using 600MCM and 600MCM-2 terminals.

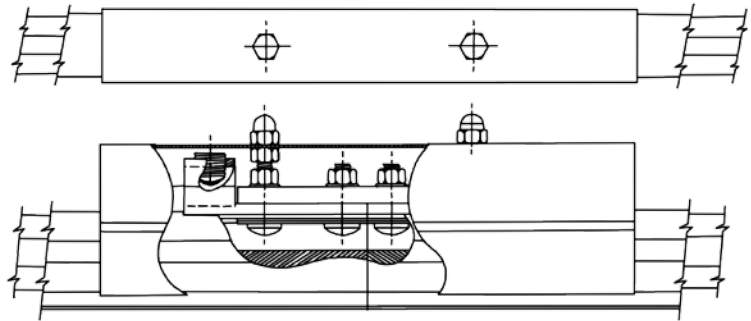

End Cap - Standard length rail having 3.25 inches exposed ends may be insulated by a 4.0 inches flexible boot or end cap. Standard and short length rail end may be insulated by a 4.0 inches extension of the cover beyond exposed rail and be designed as end lengths.

Cutting - Power rail may be field cut with a hacksaw as required. Remove sharp edges on cut conductor end by de-burring with a file.

Transfer End Caps are used on transit type conductor applications having switching mechanisms. (not illustrated)

Expansion Gaps

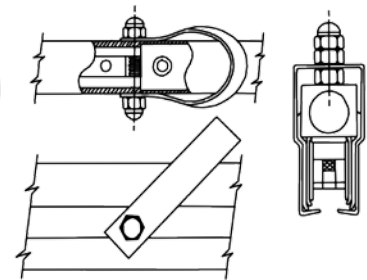
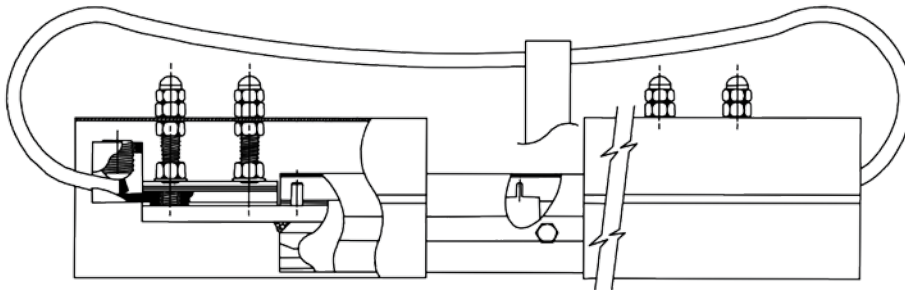

Center Slide Assembly with Cable Strap

Expansion Gap Assemblies are pre assembled, ready to be installed between two adjacent sections of rail. Each end of the expansion mechanism is attached to its mating rail end with a power feed type rail splice. The expansion mechanism is a telescoping interleaved unit, having a travel of 8.0 inches, providing a constant sliding surface for the collector shoe for mechanical support only. The gap assembly is 12.0 inches long closed and 20.0 inches expanded. The gap assembly should be set at 4.0 inches when installed at 60° F for average use.

Expansion gap assemblies are based on 500 feet conductor intervals with a 100° F temperature variation. Aluminum conductors will expand 1.0 inches in 70 feet per 100° F temperature variation. If greater temperature variations are expected, a proportional decrease in the 500 foot interval is required. Conductor systems up to 500 feet in length that are either all indoors or all outdoors can be center anchored and do not require an expansion gap assembly. Systems that are longer than 500 feet require expansion gap kits every 500 feet or fraction thereof. Systems that pass from inside to outside in areas of extreme temperature variation should have an expansion gap kit located just within the building. The center point of all conductor runs using expansion gaps requires an anchor clamp kit to locate rail settings.

Tandem Collectors are required on any crane runway system using expansion gap kits to provide current draw when passing through expansion gap mechanism.

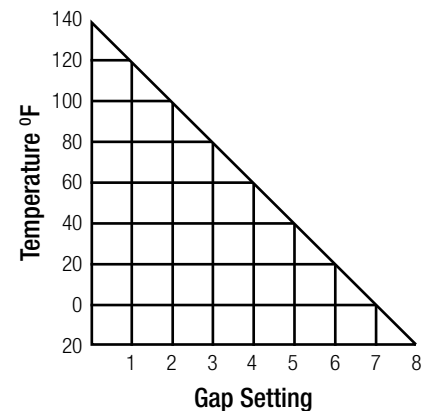

At expansion gaps keep the slide mechanism within 2 feet of brackets by adding an extra bracket 5 feet from the nearest regular bracket. Stainless steel expansion units are available for corrosive applications.

Isolation Joints are required for circuit segmentation and comprise two insulating angles with attachment hardware to secure and space the adjacent rails.

Collectors

Series "H" collectors are available in two basic designs: Series "L" single arm and Series "D" dual, parallel arm. Series "L" has a socket style, swivel base for the collector arm, resulting in a stroke of 2.0 inches and a drift of 3.0 inches. Series "D" has a post style swivel base for the collector arm with a stroke of 3.0 inches and a drift of 6.0 inches.

Contact brushes are available in 6.0 inch (size #300), 8.0 inch (size #400) and 8.0 inch (**400HS** - heat sink design).

Both designs are available in tandem for additional capacity, or when required because of expansion sections. Tandems are designed by a doubling of the size number and the design letter. Example: **HA300LS** single arm, 6.0 inch shoe; or in tandem: **HA600LLS** double arm, 2x6.0 inch shoe. See collector shoe chart for amperage selection.

Collectors may be mounted vertically or laterally without any modifications. Normal mounting dimensions will result in a 20 lb. contact shoe loading.

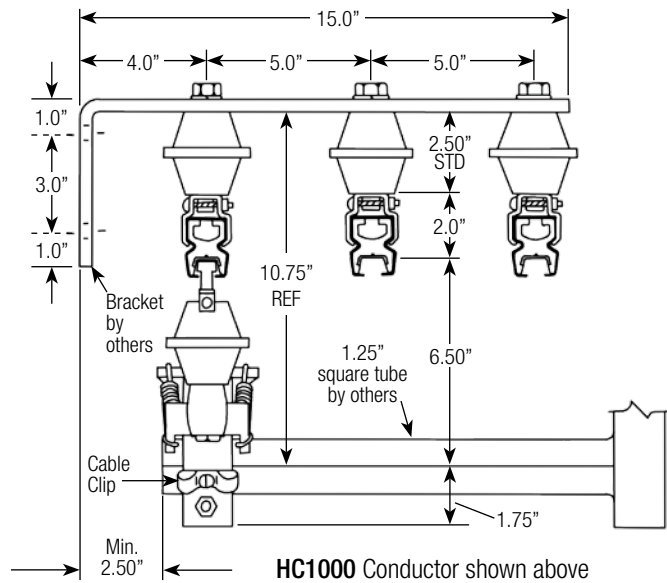

HC1000 Conductor shown above

* For HC1500 Conductor add 1.0"

Collector Shoe Rating	(1) 5/8" x 6.0"	(2) 5/8" x 6.0"	(1) 5/8" x 8.0"	(1) 5/8" x 8.0"
Continuous	200 amps	400 amps	300 amps	600 amps
Intermittent	300 amps	600 amps	450 amps	900 amps

Collector Shoe Rating	(1) 5/8" x 8.0"	(2) 5/8" x 8.0"	
Continuous	Heat Sink Design	400 amps	800 amps
Intermittent	Heat Sink Design	500 amps	1000 amps

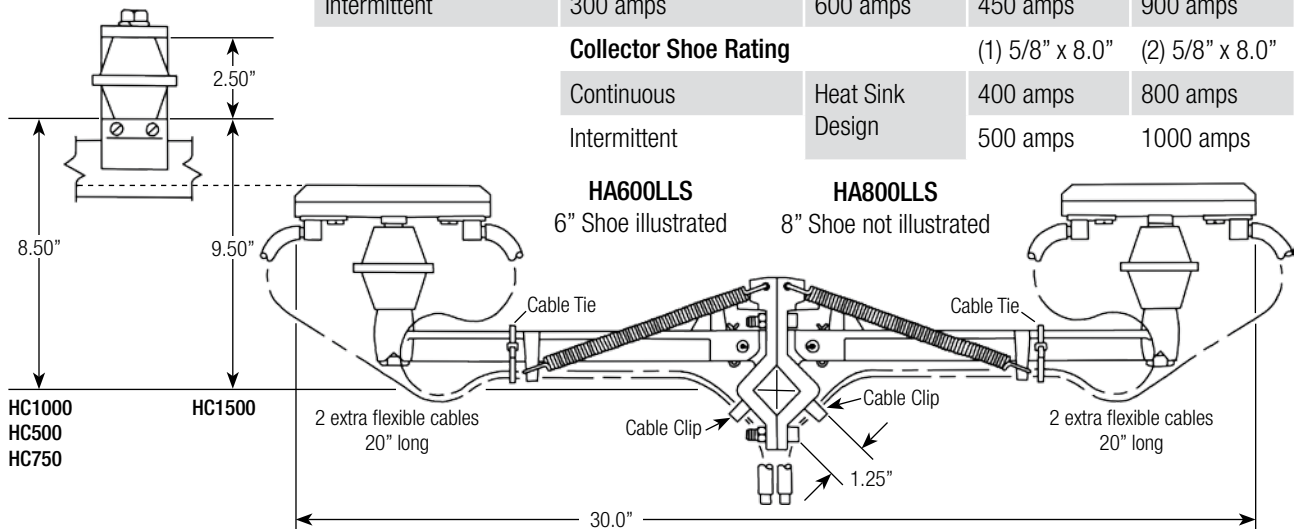

Collectors

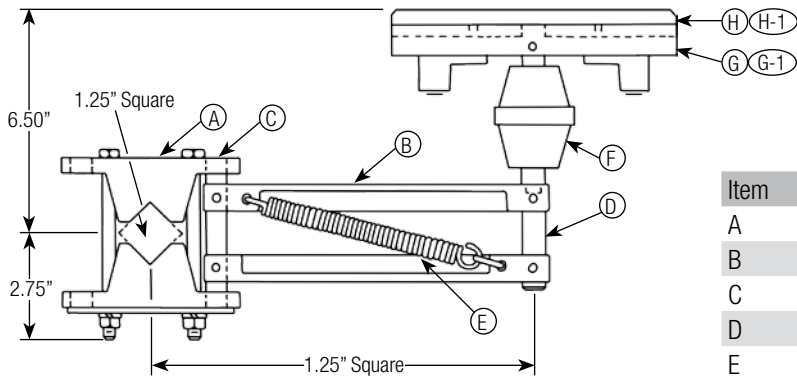

HA300DS HA600DDS
6.0" Parallel Arm Collector

HA 400D HA800DS
8.0" Parallel Arm Collector

Item	Name	Qty	Description
A	Bracket (Pair)	1	Used on 1.25" Square Bar
B	Arms	2	Opposite Pair
C	Bracket Post	1	Swivels in Bracket
D	Spool Post	1	Fitted with 0.50" - 13 Stud
E	Spring	2	Fitted with Hook
F	Spool	1	2.50" Dia. x 2.50" Hgt.
G	Shoe Clip	1	Cat No. 400YHP
H	Shoe Pair	1	Cat No. 400SHP
G-1	Shoe Clip	1	Cat No. 300YHP
H-1	Shoe Pair	1	Cat No. 300SHP

HA400DSHS
Pantograph Dual Head
with heat sink

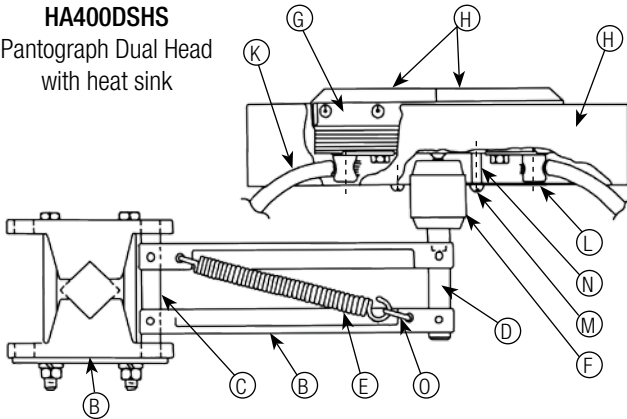

Item	Name	Qty	Description
A	Bracket (Pair)	2	Used on 1.25" Square Bar
B	Arms	2	Opposite Pair
C	Bracket Post	1	Swivels in Bracket
D	Spool Post	1	Fitted with 0.50" - 13 Stud
E	Spring	2	300Z
F	Insulator	1	1.75" Dia. x 2.25" Hgt.
G	Heat Sink	1	Aluminum
H	Shoe Pair	2	400SHP-HS
J	Shield	1	Lexan Channel
K	Cable	2	No. #2 Flex Weld Cable
L	Wire Lugs	2	No. #6 - 4/0
M	Screw (nylon)	2	0.25" -20UNC x 1.50" long
N	Sleeve (nylon)	2	0.25" ID x .1" long
O	'S' Hook	2	No. #174 - 1

Collectors

HA300LS - Single Arm 6.0" Shoe
HA600LLS - Tandem Arm 6.0" Shoe
HA400LS - Single Arm 8.0" Shoe
HA800LLS - Tandem Arm 8.0" Shoe

Item	Name	Qty	Description
HA300LS }	1	Contact Shoe	300SHP
	2	Shoe Clip	300YHP
HA600LLS }	1	Contact Shoe	300SHP
	2	Shoe Clip	300YHP
HA400LS }	1A	Contact Shoe	400SHP
	2A	Shoe Clip	400YHP
HA800LLS }	1A	Contact Shoe	400SHP
	2A	Shoe Clip	400YHP

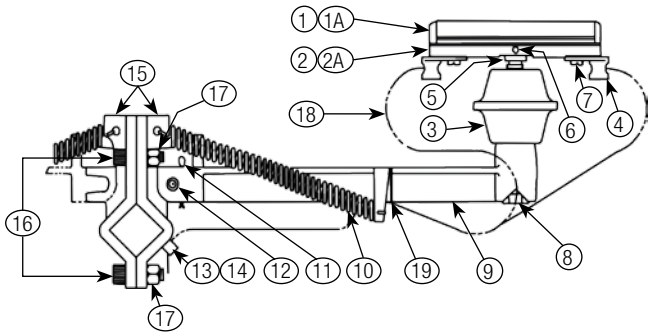

All items listed below are common except see "note" at bottom

3	Spool	1	1000 2.50" Dia x 2.50" Hgt.
4	Wire Lug	2	No. #6 - 4/0
5	Swivel Pin	1	0.50" - 13UNC
6	Rivet	1	1/8" x 0.75" Long
7	Screw	2	#10-16 x 0.50" Long Type-B
8	Hex Head Bolt	1	0.50" 13UNC x 2.25" Long
9	Long Collector Arm	1	300LP
10	Spring (pair)	2	300ZZ
11	Cotter Pin	1	Ship Only. Remove after install.
12	Roll Pin	1	3/8" Dia x 1.50" Long
13	Cable Clip	1	Burndy HP-8N
14	Screw	1	#10-32 UNF x 0.50" Long Type-D
15	Bracket (pair)	1	302BB
16	Socket Head Cap Screw	2	3/8" - 16UNC x 1.25" Long.
17	Hex Nut	2	3/8" - 16 UNC
18	Pig Tail	2	Extra Flex Cable (No #2AWG-600V x 30.0" Long)
19	Wire Tail	1	#13

PARTS LIST

Item	Amps	Lbs	Cat. No.	Item	Amps	Lbs.	Cat. No.
20' Conductor Sections Insulated PVC	500	24.0	HC500	Hanger Clamp		0.50	HA1000H
	750	24.0	HC750	Spool Clamp		1.0	HA1000K
	1000	30.0	HC1000	Plastic Clamp		0.50	HA1000P
	1500	60.0	HC1500	Anchor Hangers			
Insulated Medium Heat Plastic	500	24.0	HC500HHX20	Anchor Kit w/ Hanger Clamp		0.50	HA1000HA
	750	24.0	HC750HHX20	Anchor Kit w/ Spool Hanger		1.10	HA1000KA
	1000	30.0	HC1000HHX20	Anchor Type w/ Plastic Hanger		0.60	HA1000PA
	1500	60.0	HC1500HHX20	Expansion Gap Kit, Assembled	500	13.0	HA500XG-8"
Fiber Glass Insulated Cover	Consult Factory				750	13.0	HA750XG-8"
					1000	15.0	HA1000XG-8"
					1500	20.0	HA1500XG-8"
				Isolation Joint	All	2.0	HA1000IS
Powerfeed with Standard PVC Cover	500	3.0	HA500F	End Caps	500-1000	0.50	HA1000N
	750	3.0	HA750F		1500	0.75	HA1500N
	1000	3.0	HA1000F				
	1500	6.0	HA1500F				
Joint Kit with Standard PVC Cover	500	1.0	HA500J				
	750	1.5	HA750J				
	1000	2.0	HA1000J				
	1500	3.0	HA1500J				

www.conductix.us

Conductix-Wampfler

10102 F Street
Omaha, NE 68127
USA

Customer Support
Phone: 800 521 4888
Fax: 800 780 8329

Phone: 402 339 9300
Fax: 402 339 9627

info.us@conductix.com
www.conductix.com

