

BUDGIT Air Motor Drives for Crane Bridge Kits use the same mechanical parts as for Electric Motor Drives. The electric motor, controls and push button of the electric motor drive are replaced by an air motor, control valve and pendant control assembly.

This supplement, which contains instructions and parts lists pertaining to the air motor, control valve and pendant control assembly, is to be used in conjunction with the relevant parts of 113535-2 and 113535-6 to provide information for the Air Motor Driven Bridges.

CONNECTING BRIDGE TO AIR SERVICE

1. The recommended operating air pressure for the BUDGIT Air Motor Driven Bridge is 90 psi. When line pressure exceeds 100 psi (at full motor when the motor is operating), it is recommended that a pressure regulator valve be provided in the air supply to maintain proper pressure. **Never** drive this motor with combustible gas.

2. A filter lubricator unit (Figure 3) **must** be installed between the air source and the air hose leading to the bridge. These keep air flowing to the motor free of dirt and add lubricant to the air so internal parts of the motor are constantly lubricated. Use a good grade of spindle oil, approximate viscosity 180 ssu at 100° F, air powered tool oil, or S.A.E. 10W machine oil. BUDGIT distributors can provide filter-lubricator units.

3. The air intake elbow on the bridge motor should point away from the runway beam.

- a. Use close nipple in the elbow to attach tee as shown in Figure 9. b. Connect motor to nearest filtered and lubricated air source using 3/4" I.D. air hose attached to tee. Avoid use of hose assemblies of smaller diameters that will cause air flow restrictions and reduce bridge performance.
- c. Provide sufficient hose to reach from air source to farthest point of bridge travel. BUDGIT Hose Trolleys are one recommended means of keeping hose up out of the way.
- d. Attach hose assemblies as shown in Figure 11.

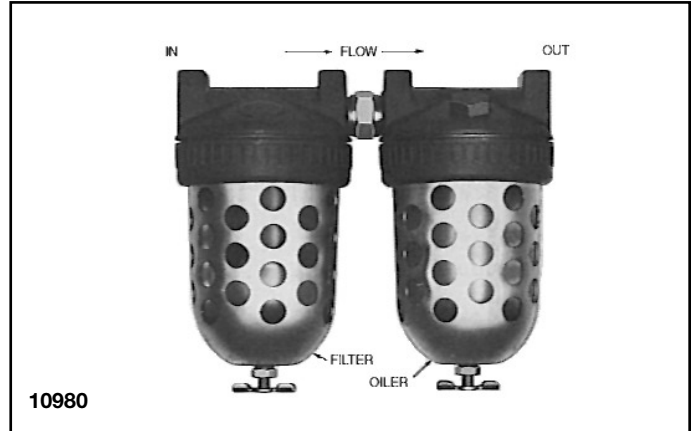

Figure 3. Air Filter and Lubricator Unit

LUBRICATION

Servicing the air line filter and lubricator unit is of primary importance since it is the only source of lubrication for the control valve, and air motor. Fill lubricator with good grade of light spindle oil, air powered tool oil, or S.A.E. 10W machine oil.

MAINTENANCE

1. BUDGIT Air Motor Driven Bridges are built to give long service, but should be inspected periodically for evidence of damage or wear, particularly when subjected to unusually severe operating conditions.
2. Inspection of the pendant throttle control assembly.
 - a. Disassembly. (See Figure 11.)
 - (1) Disconnect three air hoses from top of throttle control assembly.
 - (2) Remove wire rope clips holding wire rope strain cable for pendant throttle control assembly and disconnect wire rope.
 - (3) Remove two large hex head threaded caps from throttle control assembly side opposite control levers.

- (4) Remove spring from under each cap.
- (5) Remove each spool valve by threading a #10-24 screw into the tapped hole in the valve and pulling valve out.

b. Reassembly. (See Figure 11.)

- (1) Before assembly, all parts should be thoroughly cleaned and inspected to determine their serviceability. Replace all parts that are worn or damaged.
- (2) Reassemble parts in reverse of the disassembly steps above.

3. Inspection of supply head assembly.

a. Disassembly. (See Figure 9.)

- (1) Disconnect three air hoses leading to pendant throttle control assembly.
- (2) Remove two hex socket cap screws and lock-washers on side of supply head assembly and remove supply head assembly from air motor body.
- (3) To gain access to the valves, remove the retaining rings and screens. at the ports and pull out the muffling material.
- (4) Remove the two pan head screws on the side of the supply head assembly to release the valves inside the assembly.
- (5) Pull valve sleeve, spring, and stem out of the supply head assembly. Valve parts may be reached by using needle nose pliers.

Steps (3) thru (6) can also be accomplished with supply head assembly in place.

b. Reassembly. (See Figure 9.)

- (1) Before assembly, all parts should be thoroughly cleaned and inspected to determine their serviceability. Replace all parts that are worn or damaged.
- (2) Install valve springs and stems in sleeves and lubricate.
- (3) Slide sleeves into position in supply head (small, single hole on side of sleeves must align with retaining screws) and reinstall retaining screws.
- (4) Replace supply head gasket. Position gasket so that no portion of ports is covered.

4. Inspection of air motor.

a. For removal of supply head assy. see Paragraph 3.

b. Disassembly. (See Figure 10.)

- (1) Remove four hex socket cap screws and then remove motor from gearbox.

- (2) Remove three fillister head screws, end cap and gasket.
- (3) Remove six hex head bolts holding rear end plate to motor cylinder.
- (4) Hold the shaft in a soft jawed vise and using a puller, adapted to fit the three #10-32 bolt centers of the end cap, remove rear end plate and shim gasket. Do not try to pry the end plate from the motor.
- (5) Remove six hex socket cap screws from front end plate.
- (6) Remove motor body exposing the rotor assembly while leaving front end plate mounted on shaft. This relationship must be maintained to eliminate the necessity of adjusting the motor upon reassembly.
- (7) Remove vanes, springs and pins.

Note: Motors requiring further disassembly should be sent to an authorized BUDGIT repair station for repairs.

- (8) Check for worn or damaged rotor vanes. Inspect ball bearings and check condition of rotor, shaft, cylinder and end plates. Any repairs beyond replacing vanes, springs and pins would best be done at an authorized BUDGIT repair station. Repair or replace defective parts as noted in the following steps.
 - (a) Rotor. Examine end faces for roughness and vane slots for wear and burrs. A new vane should move in and out without binding. Smooth roughness on end faces and remove sharp edges or burrs at slot corners using a hone. Replace motor if rotor and shaft assembly is excessively worn or damaged.
 - (b) Cylinder. Examine surface of bore diameter for rough circular grooves from scoring. If the cylinder is badly scored, it must be replaced. A badly scored cylinder cannot be restored by honing since it will only enlarge the bore diameter, widening the seal point between the rotor and cylinder, resulting in a loss of speed and power. If the cylinder is replaced, new shim gaskets of the proper thickness are required to maintain the original spacing of the end plates.
 - (c) End Plates. Check faces of front and rear end plates for wear or scoring. If wear depth is greater than .005 inches, end plates should be replaced. Light score marks can be lapped out with 150-grit abrasive cloth on a flat surface.

motor an authorized BUDGIT repair station. Do not, under any circumstances, wash sealed bearings or blow off with a high pressure air hose.

c. Reassembly. (See Figure 10.)

- (1) Before assembly, all parts should be thoroughly cleaned and inspected to determine their serviceability. Replace all parts that are worn or damaged.
- (2) Position assembly vertically with rotor facing upward. Insert push pins in rotor. Place shim gasket and motor body on end plate, using dowel pins for positioning. Insert vanes and springs into rotor. Take care that spring tab is positioned in slot of vane.
- (3) Install six hex socket head screws through front end plate.
- (4) Place shim gasket and rear plate on body, using dowel pins for positioning. Press rear bearing onto rotor shaft by pressing on inner race. Bearing outer race should not be bottomed on rear end plate. Shaft must not move laterally in front bearing.
- (5) Install six hex head bolts through rear end plate.
- (6) Replace end cap and gasket and install three fillister screws.
- (7) Rotor and shaft must turn freely in body.
- (8) Position motor in proper orientation on bridge gearbox with key in place and fasten with four hex socket head screws.

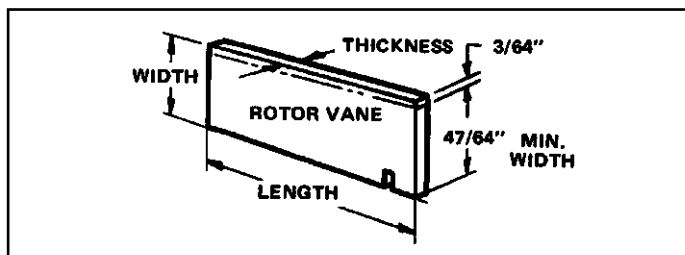

Figure 4. Rotor Vane

(d) Rotor Vanes and Springs. Inspect the rotor vanes for wear, scoring, warpage or other damage. Compare the width of the old vane with a new one to determine the amount of wear that has taken place on the width. If the old vane is more than 3/64" less than the new vane (in width), it must be replaced. An old vane that shows wear on the thickness must also be replaced. Vanes worn in this manner will eventually fail, resulting in costly repairs, and unexpected down time on the bridge. Warped vanes must also be replaced as the vanes must move in and out of the rotor slot without binding. Inspect leaf springs and centering pins. Worn areas on springs can cause eventual spring breakage and motor lock up.

Replace worn springs, particularly when vanes are replaced.

(e) Motor Bearings. Check motor bearings, especially the bearing at the extended shaft end of the motor, for excessive looseness or binding. If bearing requires replacement, send

REPLACEMENT PARTS

The following parts lists and drawings cover parts not included in 113535-2 AND 133535-6.

The factory recommends complete replacement of the air motor or gearbox. Service is available, however, from your authorized BUDGIT repair station.

The numbers assigned to the parts of our various assemblies in our parts list are not the part numbers used in manufacturing the part. They are identification numbers, that when given with the model number, permit us to identify, select or manufacture and ship the correct part needed.

INDEX OF PARTS ILLUSTRATION		
Figure No.	Title	Page No.
9	Supply Head Assembly	5
10	Air Motor	6
11	Pendant Throttle Control	7

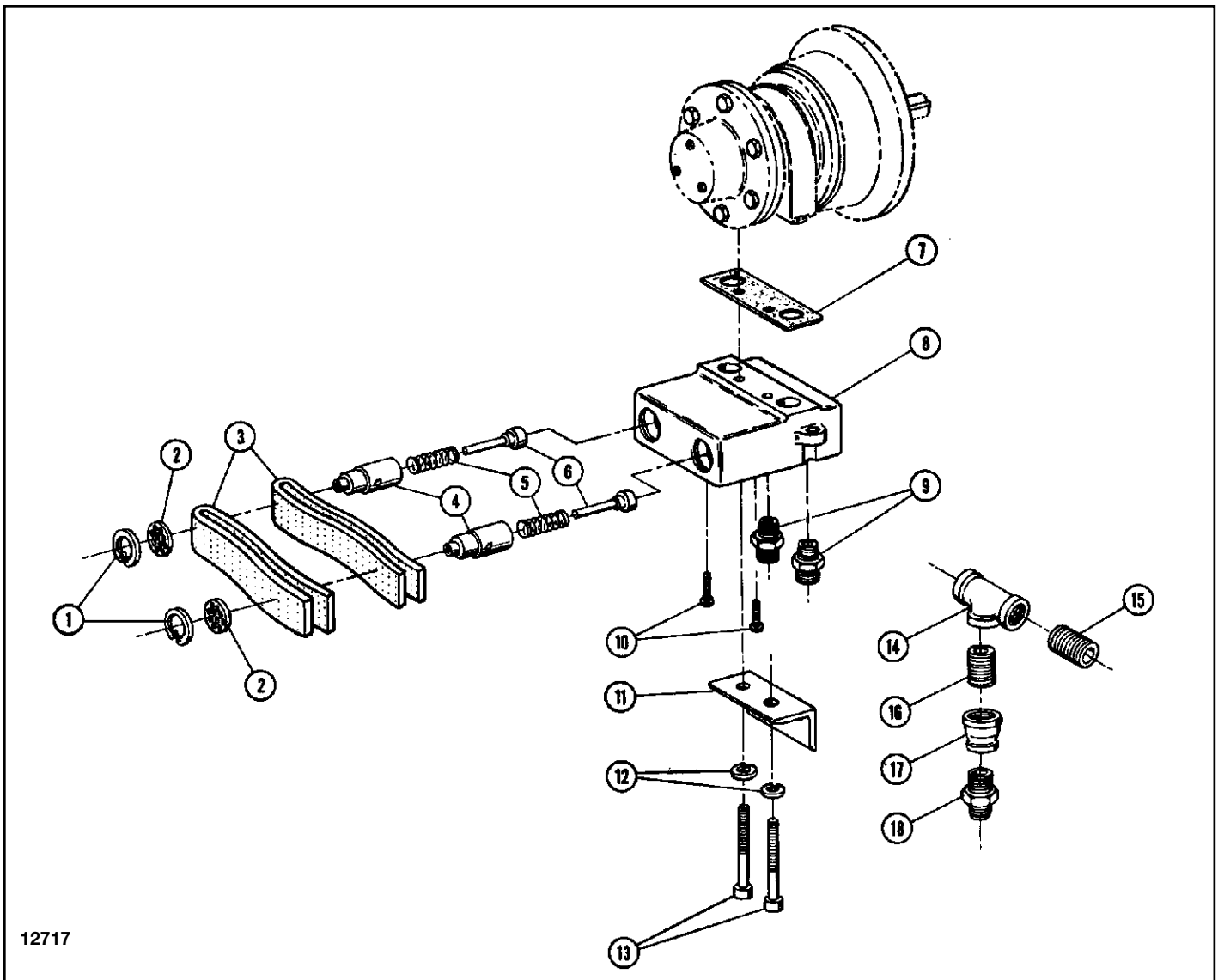

12717

Figure 9. Supply Head Assembly

Ref. No.	Part Number	Description	Qty. Req'd
1	BAH-5105	Ring - Internal Retaining	2
2	BAH-5104	Screen - Exhaust Valve	2
3	BAH-5103	Muffling Material	2
4	BAH-5125	Sleeve - Valve	2
5	BAH-5124	Spring - Valve	2
6	BAH-5123	Stem - Valve	2
7	BAH-5114	Gasket - Supply Head	1
8	BAH-5100	Supply Head	1
9	BAH-5107	Adaptor Fitting	2
10	BAH-5106	Screw -Self Tapping	2
11	BAT-700	Anchor - Cable	1
12	BAH-5113	Lockwasher	2
13	BAH-5112	Cap Screw - Hex Socket	2
14	BAT-701	Tee - Reducing	1
15	BAT-702	Nipple - Close Pipe	1
16	BAH-5110	Nipple - Close Pipe	1
17	BAT-703	Coupling - Reducing	1
18	BAH-5107	Adaptor Fitting	1

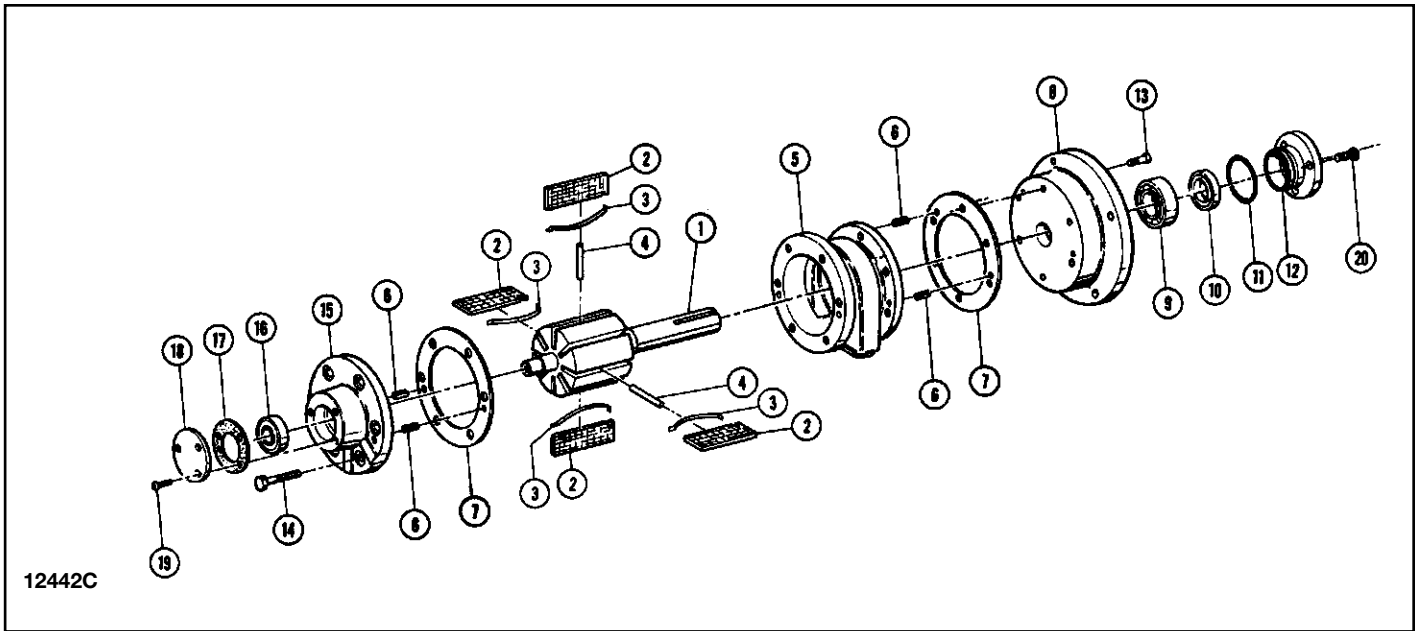

Figure 10. Air Motor

Ref. No.	Part Number	Description	Qty. Req'd
1	BAT-800	Air Motor Assembly	1
1	BAT-801	Rotor and Shaft Assembly	1
2	BAH-5202	Vane	8
3	BAH-5203	Spring - Vane	8
4	BAT-808	Push Pin	4
5	BAT-802	Body - Air Motor	1
6	BAH-5206	Pin - Dowel	4
7	BAH-5207	Gasket - Body	2
8	BAT-803	End Plate - Drive End	1
9	BAT-804	Bearing - Drive End	1
10	BAT-805	Shaft Seal	1
11	BAT-806	O-Ring	1
12	BAT-807	Cap	1
13	BAH-5222	Screw	6
14	BAH-5221	Screw	6
15	BAH-5215	End Plate - Dead End	1
16	BAH-5216	Bearing - Dead End	1
17	BAH-5217	Gasket - End Cap	1
18	BAH-5218	End Cap - Dead End	1
19	BAH-5219	End Plate Puller Tool (Not Shown)	-
19	BAH-5220	Screw	3
20	BAT-809	Screw - Hex Socket Head	3

NOTES

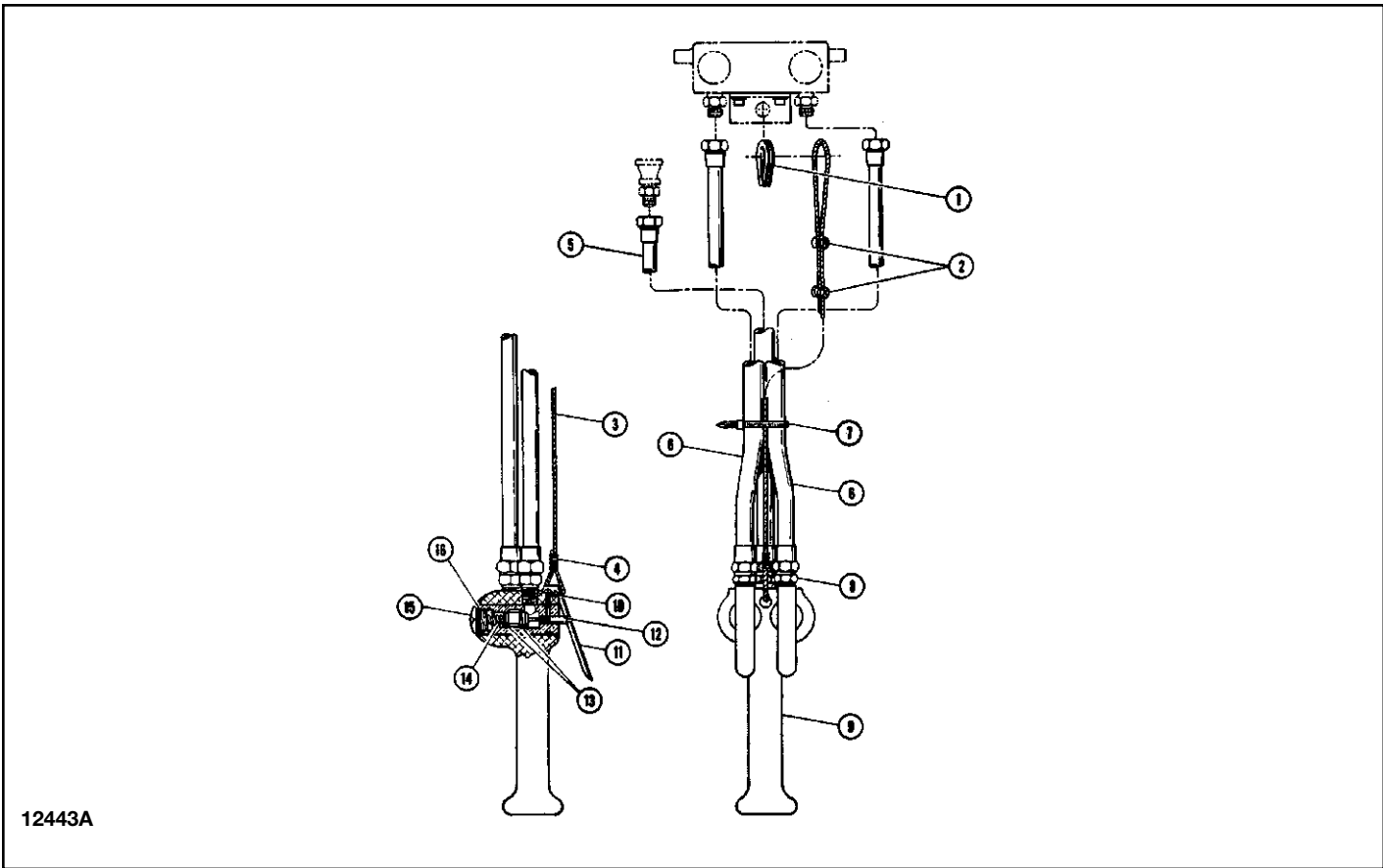
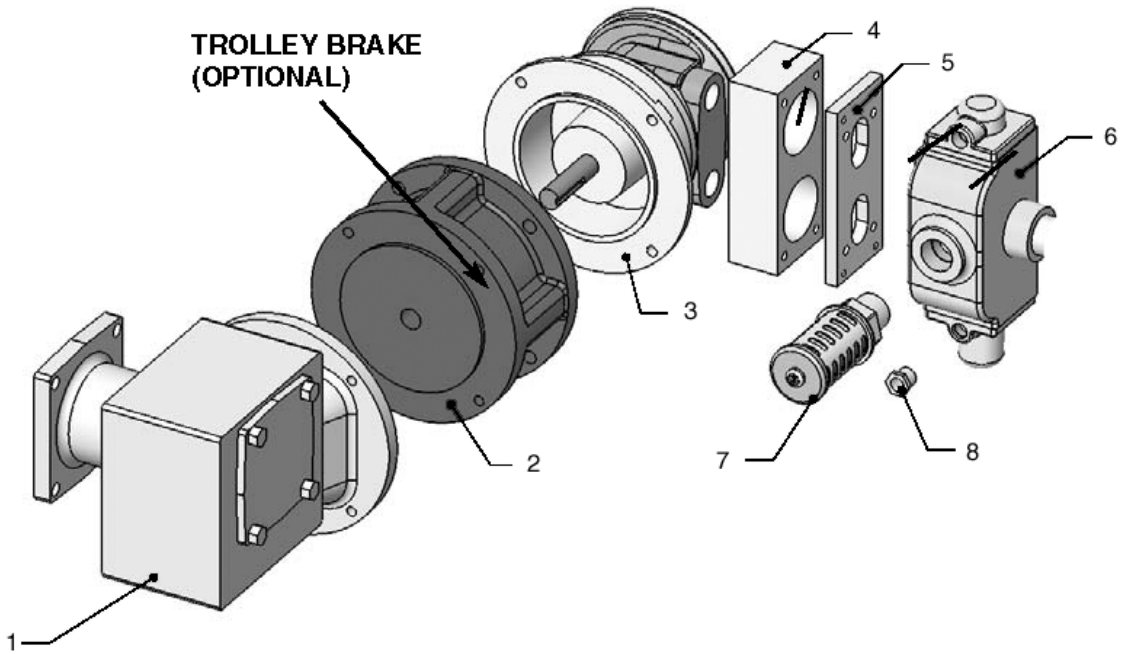

Figure 11. Pendant Throttle Control

Ref. No.	Part Number	Description	Qty. Req'd
1	BAH-5302	Thimble -Wire Rope	1
2	BAH-5304	Clip -Wire Rope	2
3	BAH-5305	Cable - Strain Relief (Specify Length Required)	
		7 ft-, 6 in. for 10 ft. Hoist Lift	1
		10 ft. 6 in. for 13 ft. Hoist Lift	1
		12 ft. 6 in. for 15 ft. Hoist Lift	1
		17 ft. 6 in. for 20 ft. Hoist Lift	1
	BAH-5306	Sleeve - Pressed	1
	BAT-900	Hose Assembly - Supply	
		For 10 ft. Hoist Lift	1
	BAT-901	For 13 ft. Hoist Lift	1
	BAT-902	For 15 ft. Hoist Lift	1
	BAT-903	For 20 ft. Hoist Lift	1
	BAT-904	Hose Assembly - Control	
		For 10 ft. Hoist Lift	2
	BAT-905	For 13 ft. Hoist Lift	2
	BAT-906	For 15 ft. Hoist Lift	2
	BAT-907	For 20 ft. Hoist Lift	2
7	BAH-5316	Tie - Cable	4
8	BAH-5317	Adaptor Fitting	3
9	BAT-908	Pendant Throttle Handle Assy - Complete (Includes Ref. Nos. 10 thru 16 Plus Handle)	
10	BAH-5319	Pin - Throttle Lever	1
11	BAH-5320	Throttle Lever	1
12	BAH-5321	Valve - Throttle	2
13	BAH-5322	Ring - Throttle Valve Seal	2
14	BAH-5323	Spring - Throttle Valve	4
15	BAH-5324	Cap - Throttle Valve	2
16	BAH-5325	Seal -Throttle Valve Cap	2

MOTOR AND GEAR BOX ASSEMBLY
2 thru 7½ Ton Motor and Gear Box Assembly



14001

Ref. No.	Part Number	Description	Qty. Req'd
1	905378	Gear Box Assembly	1
2		Air Brake - (contact factory)	1
3	43891301	Air Motor	1
4	22925703	Mounting Plate	1
5	22925501	Sandwich Plate	1
6	22746302	Valve	1
7	227472-1	Muffler	1
8	53039	Hex Bushing	1
9*	11443301	Gasket	1
10*	22746801	Gasket	1

*Not Shown

NOTES

AIR MOTOR COMPONENTS

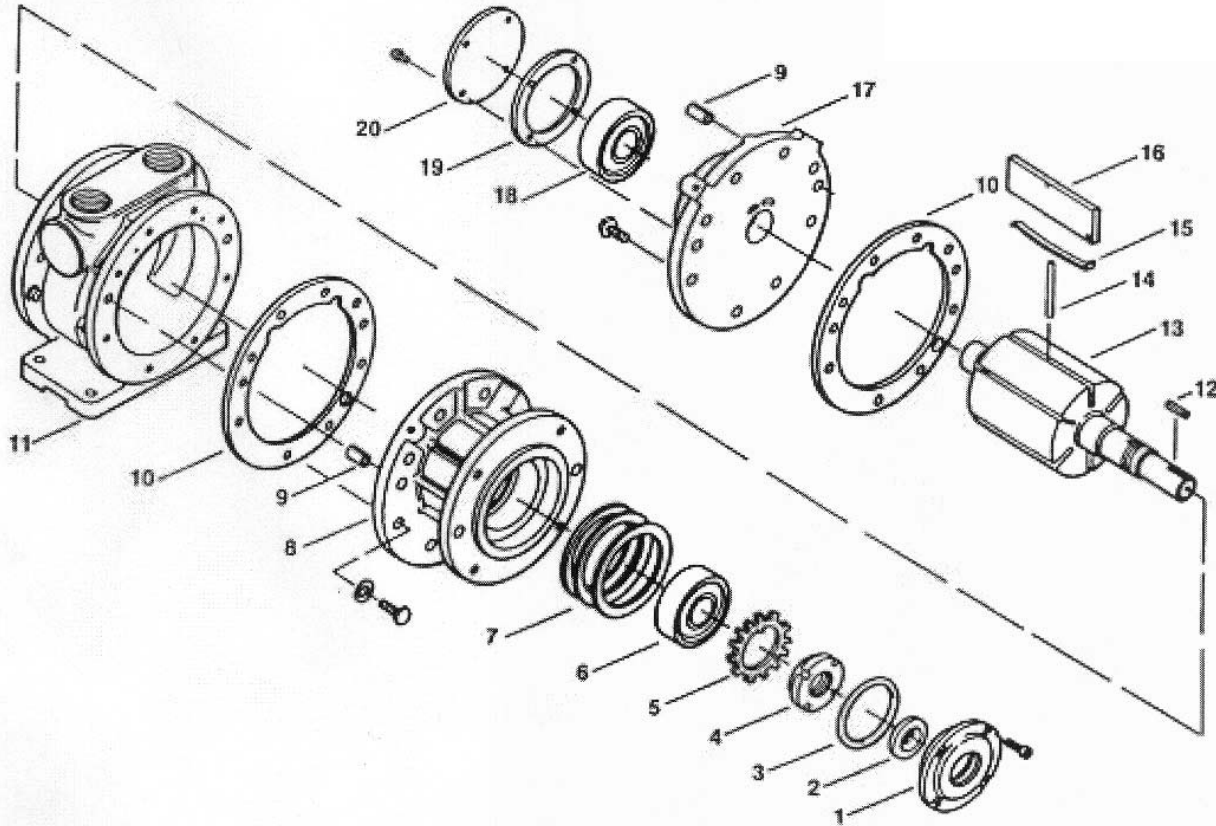

14002

Ref. No.	Description	Qty. Req'd
1	Drive End Cap	1
2*	Seal	1
3*	O-Ring	1
4	Locknut	1
5*	Lockwasher	1
6*	Drive End Bearing	1
7	Spacer	1
8	Drive End Plate	1
9	Dowel Pin	4
10*	Spacer Gasket	2
11	Body	1
13	Rotor Assembly	3
14*	Push Pin	6
15*	Vane Spring	6
16*	Vane	1
17	Dead End Plate	1
18	Dead End Bearing	1
19	End Cap Gasket	1
20	Dead End Cap	1
*	Service Kit 652-308	1

*Call Factory For Air Motor Rebuild Kit

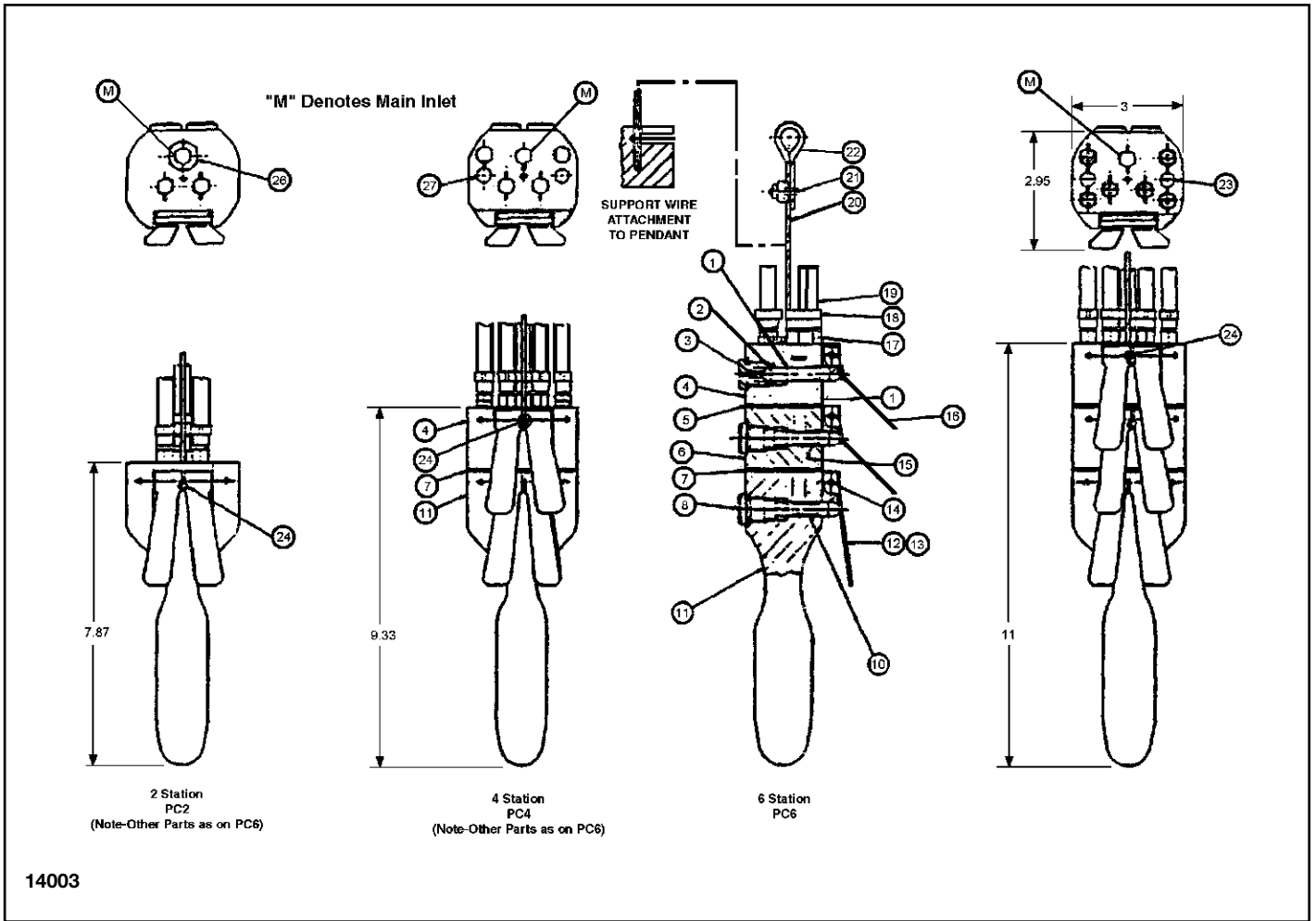

Figure 4. Pendant Control Assemblies PC2, PC4 & PC6

REF. NO.	PART NUMBER	DESCRIPTION	QUANTITY REQUIRED		
			2 STATION	4 STATION	5 STATION
		Pendant Control Station			
	700AH-401	2 Station	1	--	--
	700AH-402	4 Station	--	1	--
	700AH-403	6 Station	--	--	1
1	700AH-404	O-Ring	2	6	10
2	700AH-405	O-Ring	2	4	6
3	700AH-406	Compression Spring	2	4	6
4	700AH-407	Top Body	--	1	1
5	700AH-408	Gasket	--	--	1
6	700AH-409	Intermediate Body	--	--	1
7	700AH-410	Gasket	--	1	1
8	700AH-411	Valve Plug	2	4	6
10	700AH-412	Plunger	2	2	2
11	700AH-413	Handle	1	1	1
12	700AH-414	"Raise" Lever	1	1	1
13	700AH-415	"Lower" lever	1	1	1
14	700AH-416	Lever Pivot Pin	1	1	1
15	700AH-417	Plunger	--	2	4
16		Lever			
	700AH-418	Trolley Left	--	1	1
	700AH-419	Trolley Right	--	1	1
	700AH-418	Bridge Forward	--	--	1
	700AH-419	Bridge Reverse	--	--	1
23	700AH-422	Hex Head Bolt	--	--	2

Recommended Spare Parts for Your Budgit Air Motor Driven Bridge

Certain parts of your air motor will, in time, require replacement under normal wear conditions. It is suggested that the following parts be purchased as spares for future use.

- 1 Set of Oil Seals
- 1 Set of Motor Vanes
- 1 Set of Motor Springs
- 1 Set of Motor Pins

Note: When ordering parts always furnish Model Number, Catalog Number and Motor Nameplate Date of the bridge on which the parts are to be used.

Parts for your hoist are available from your local authorized **BUDGIT** repair station. For the location of your nearest repair station, contact us at:

Phone: (800) 888-0985 • Fax: (800) 689-5644

WARRANTY

WARRANTY AND LIMITATION OF REMEDY AND LIABILITY

A. Seller warrants that its products and parts, when shipped, and its work (including installation, construction and start-up), when performed, will meet applicable specifications, will be of good quality and will be free from defects in material and workmanship. All claims for defective products or parts under this warranty must be made in writing immediately upon discovery and in any event, within one (1) year from shipment of the applicable item unless Seller specifically assumes installation, construction or start-up responsibility. All claims for defective products or parts when Seller specifically assumes installation, construction or start-up responsibility and all claims for defective work must be made in writing immediately upon discovery and in any event, within one (1) year from completion of the applicable work by Seller, provided; however, all claims for defective products and parts made in writing no later than eighteen (18) months after shipment. Defective items must be held for Seller's inspection and returned to the original f.o.b. point upon request. THE FOREGOING IS EXPRESSLY IN LIEU OF ALL OTHER WARRANTIES WHATSOEVER, EXPRESS, IMPLIED AND STATUTORY, INCLUDING, WITHOUT LIMITATION, THE IMPLIED WARRANTIES OF MERCHANTABILITY AND FITNESS.

B. Upon Buyer's submission of a claim as provided above and its substantiation, Seller shall at its option either (i) repair or replace its product, part or work at either the original f.o.b. point of delivery or at Seller's authorized service station nearest Buyer or (ii) refund an equitable portion of the purchase price.

C. This warranty is contingent upon Buyer's proper maintenance and care of Seller's products, and does not extend to normal wear and tear. Seller reserves the right to void warranty in event of Buyer's use of inappropriate materials in the course of repair or maintenance, or if Seller's products have been dismantled prior to submission to Seller for warranty inspection.

D. The foregoing is Seller's only obligation and Buyer's exclusive remedy for breach of warranty and is Buyer's exclusive remedy hereunder by way of breach of contract, tort, strict liability or otherwise. In no event shall Buyer be entitled to or Seller liable for incidental or consequential damages. Any action for breach of this agreement must be commenced within one (1) year after the cause of action has accrued.

BUDGIT[®]
Hoists