

Abell-Howe floor mounted jib crane

SPECIFICATIONS

MAST: Fabricated from heavy wall structural steel pipe with wall thickness sized to minimize deflection.

BASE PLATE: Large diameter base plate is reinforced with heavy steel gussets for continuous alignment and rigidity.

HEAD SECTION: Rigid steel plate box type with welded construction for minimum deflection between boom and mast.
 – Bottom roller assembly can be shimmed for boom leveling.

BOOM: Rolled steel I-beam section with long wearing tapered flange for smooth trolley travel.
 – End stops at both ends of the boom are provided to limit trolley travel.



FEATURES

- The J-904 boom features full 360° rotation on a tapered roller bearing providing full capacity vertical and radial thrust loading.
- The lower section of the head revolves around the pillar on a pair of steel rollers equipped with self-aligning roller bearings.
- Available in hand push, hand geared rotation, air or electric motor drives.
- J-904 Pillar Jib Cranes are available as standard in capacities from 500-20,000 lbs, spans to 30 ft and under boom height from 8 to 30 ft.
- Larger capacity & special configurations are available upon request.

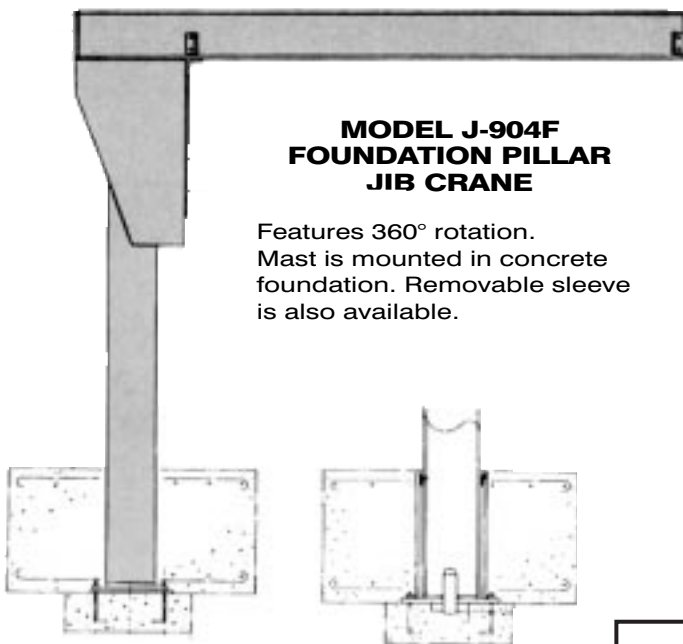

**MODEL J-904F
FOUNDATION PILLAR
JIB CRANE**

Features 360° rotation.
 Mast is mounted in concrete foundation. Removable sleeve is also available.

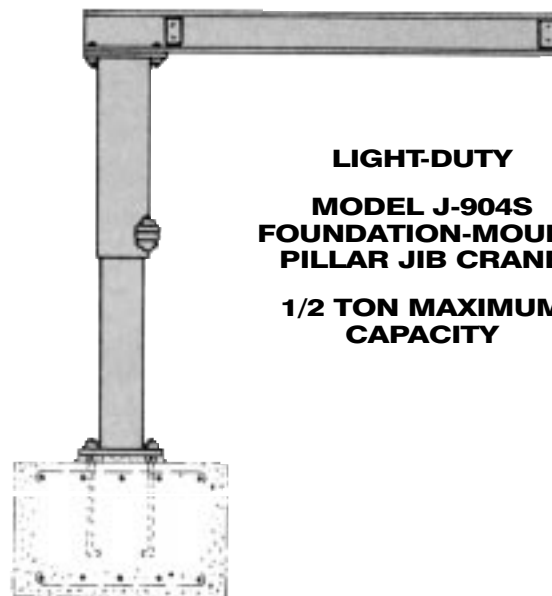

**LIGHT-DUTY
MODEL J-904S
FOUNDATION-MOUNT
PILLAR JIB CRANE**

**1/2 TON MAXIMUM
CAPACITY**

* ⚠ WARNING

Overloading and improper use can result in injury.

To avoid injury:

- Do not exceed working load limit, load rating or capacity.
- Do not use to lift people or loads over people.
- Use only alloy chain for overhead lifting.
- Read and follow all instructions.